

**Permissible radial force**

$$Fr_{zul} = \min(f_w \times f_\alpha \times Fr_{Tab}; f_w \times Fr_{max})$$

At  $Fr$  and  $Fa \neq 0$  please contact your Lenze sales office.

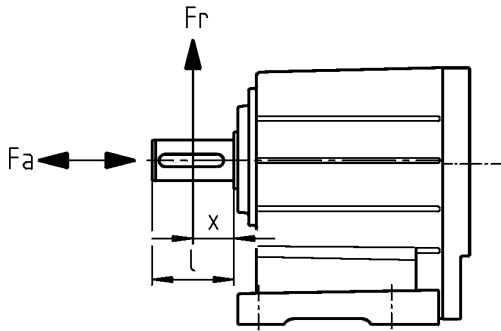

**Permissible axial force**

$$Fa_{zul} = Fa_{Tab} \text{ at } Fr = 0$$

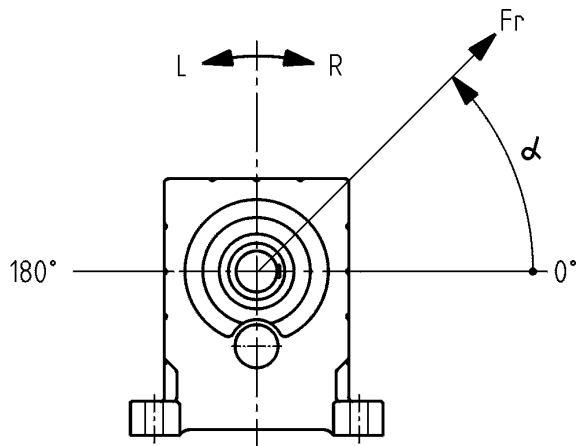

**Effective direction factor  $f_\alpha$  at output shaft**

GST03-2

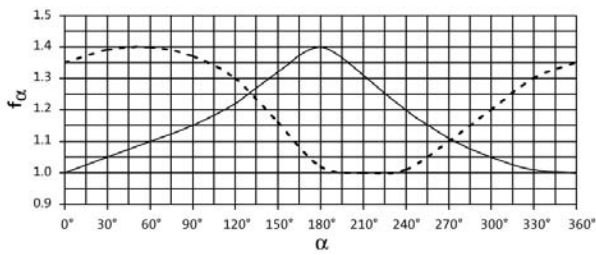

GST04...09-1

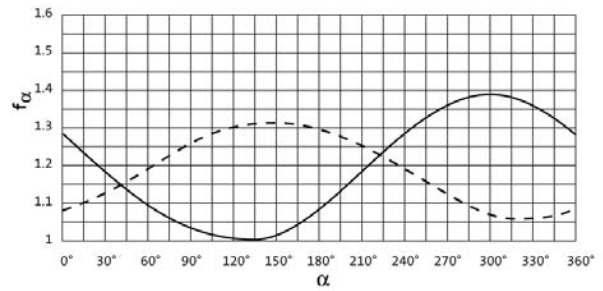

GST04...09-2, 3

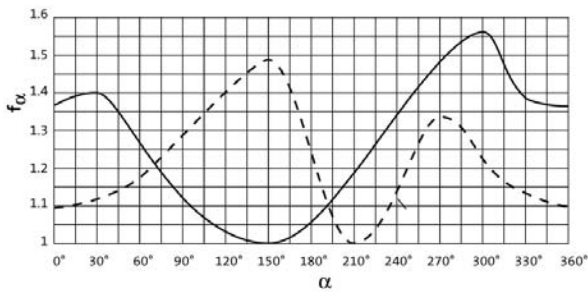

GST11...14-2, 3

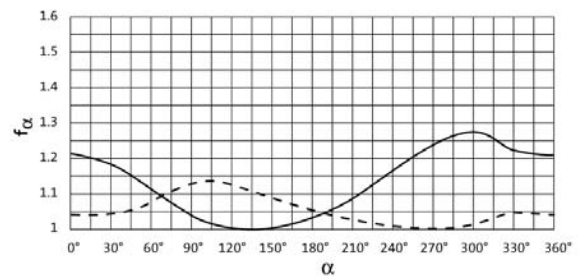

—— Direction of rotation R

- - - Direction of rotation L

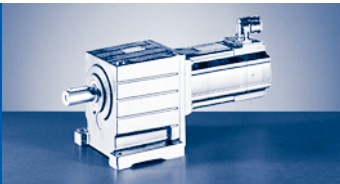

GST [N]

### Additional load factor $f_w$ at output shaft

GST03-2

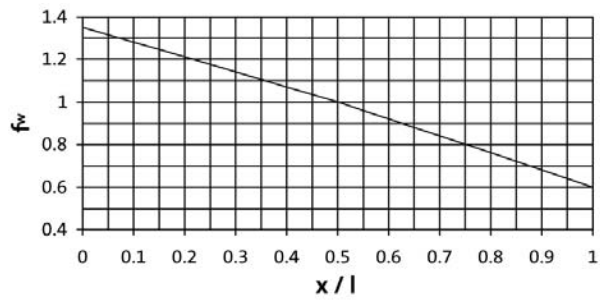

GST04...14-1, 2, 3

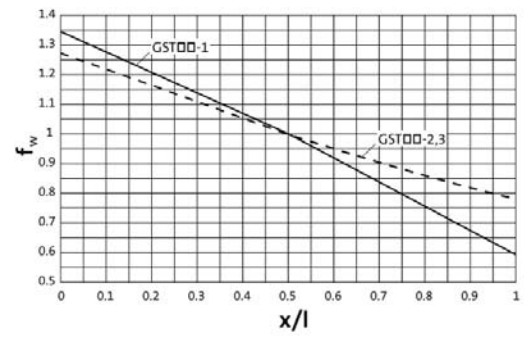

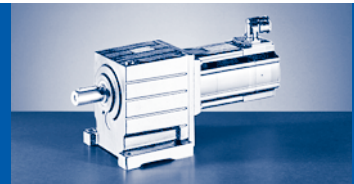

## GST□□-1

		Solid shaft (V□□) Application of force Fr: centre of shaft journal (x = l/2) Fa <sub>Tab</sub> only valid for Fr = 0									
		GST04-1		GST05-1		GST06-1		GST07-1		GST09-1	
n <sub>2</sub> [r/min]	Fr <sub>Tab</sub> [N]	Fa <sub>Tab</sub> [N]	Fr <sub>Tab</sub> [N]	Fa <sub>Tab</sub> [N]	Fr <sub>Tab</sub> [N]	Fa <sub>Tab</sub> [N]	Fr <sub>Tab</sub> [N]	Fa <sub>Tab</sub> [N]	Fr <sub>Tab</sub> [N]	Fa <sub>Tab</sub> [N]	
2500	100	600	100	800	200	900	700	1200	1750	2500	
1600	180	800	250	1100	600	1200	1000	1600	2200	3400	
1000	440	1000	550	1400	800	1500	1200	2000	2500	4300	
600	600	1300	750	2000	800	2000	1300	2700	2500	5700	
400	850	1400	1400	2000	1100	2500	1900	3300	3500	6800	
200	1050	1400	2000	2000	2200	2500	3000	3700	6200	7000	
125	1050	1400	2300	2000	2900	2500	3900	3700	7900	7000	
80	1050	1400	2300	2000	3500	2500	4700	3700	9000	7000	
≤ 50	1050	1400	2300	2000	3500	2500	5300	3700	9500	7000	
Fr <sub>max</sub>	1050	-	2300	-	3500	-	5300	-	9500	-	

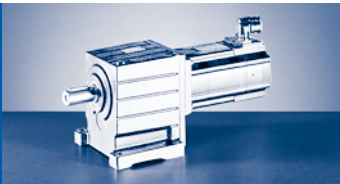

# GST [N]

## GST□□-2/3 with standard bearings

		Solid shaft (V□□) Application of force Fr: centre of shaft journal (x = l/2) Fa <sub>Tab</sub> only valid for Fr = 0															
		GST03-2		GST04-2		GST05-2/3		GST06-2/3		GST07-2/3		GST09-2/3		GST11-2/3		GST14-2/3	
n <sub>2</sub> [r/min]	Fr <sub>Tab</sub> [N]	Fa <sub>Tab</sub> [N]	Fr <sub>Tab</sub> [N]	Fa <sub>Tab</sub> [N]	Fr <sub>Tab</sub> [N]	Fa <sub>Tab</sub> [N]	Fr <sub>Tab</sub> [N]	Fa <sub>Tab</sub> [N]	Fr <sub>Tab</sub> [N]	Fa <sub>Tab</sub> [N]	Fr <sub>Tab</sub> [N]	Fa <sub>Tab</sub> [N]	Fr <sub>Tab</sub> [N]	Fa <sub>Tab</sub> [N]	Fr <sub>Tab</sub> [N]	Fa <sub>Tab</sub> [N]	
1000	100	300	730	600	1150	1200	140	500	140	1100	1500	1300	11500	5700	16600	9000	
630	300	400	950	800	1500	1600	750	600	2050	1500	1950	1800	14400	7600	20700	12000	
400	630	600	1250	1100	1950	2000	2350	850	3400	1900	6800	2300	17000	9500	24000	15000	
250	710	700	1450	1300	2200	2300	2600	900	3800	2200	7600	2800	19000	10000	27000	16000	
160	800	800	1700	1650	2600	2650	3100	1250	4500	2900	9400	4000	21000	11000	31000	18000	
100	920	900	2100	2000	3000	3100	3600	1800	5400	3900	11500	5600	21000	14000	36000	20000	
63	1100	1000	2500	2000	3500	3600	4300	2600	6400	5300	11500	8100	21000	16000	39000	20000	
40	1400	1000	2650	2000	3800	3600	4350	3600	7600	7000	11500	11000	21000	16000	40000	20000	
25	1500	1000	2650	2000	3900	3600	4350	4800	9100	7000	11500	12000	21000	16000	40000	20000	
≤ 16	1500	1000	2650	2000	3900	3600	4350	4800	9500	7000	11500	12000	21000	16000	40000	20000	
Fr <sub>max</sub>	1500	-	2650	-	3900	-	4350	-	9500	-	11500	-	21000	-	40000	-	

## GST□□-2/3 with reinforced bearings

		Solid shaft (V□□) Application of force Fr: centre of shaft journal (x = l/2) Fa <sub>Tab</sub> only valid for Fr = 0									
		GST04-2		GST05-2/3		GST06-2/3		GST07-2/3		GST09-2/3	
n <sub>2</sub> [r/min]	Fr <sub>Tab</sub> [N]	Fa <sub>Tab</sub> [N]	Fr <sub>Tab</sub> [N]	Fa <sub>Tab</sub> [N]	Fr <sub>Tab</sub> [N]	Fa <sub>Tab</sub> [N]	Fr <sub>Tab</sub> [N]	Fa <sub>Tab</sub> [N]	Fr <sub>Tab</sub> [N]	Fa <sub>Tab</sub> [N]	
1000	1900	1000	3350	2100	4250	2100	5650	3300	11300	4800	
630	2350	1300	3950	2800	5100	2800	6850	4400	14000	6400	
400	2850	1700	4900	3600	6300	3500	8500	5500	16500	8000	
250	3150	1900	5400	3900	7000	3600	9500	6100	17000	9000	
160	3550	2200	5400	4300	7700	4200	10500	7100	17000	10500	
100	3750	2500	5400	4500	7700	4900	12500	8300	17000	12500	
63	3750	2500	5400	4500	7700	5700	13000	9000	17000	14000	
40	3750	2500	5400	4500	7700	5700	13000	9000	17000	14000	
25	3750	2500	5400	4500	7700	5700	13000	9000	17000	14000	
≤ 16	3750	2500	5400	4500	7700	5700	13000	9000	17000	14000	
Fr <sub>max</sub>	3750	-	5400	-	7700	-	13000	-	17000	-	

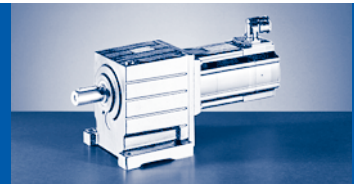

Output backlash in angular minutes

GST03-2

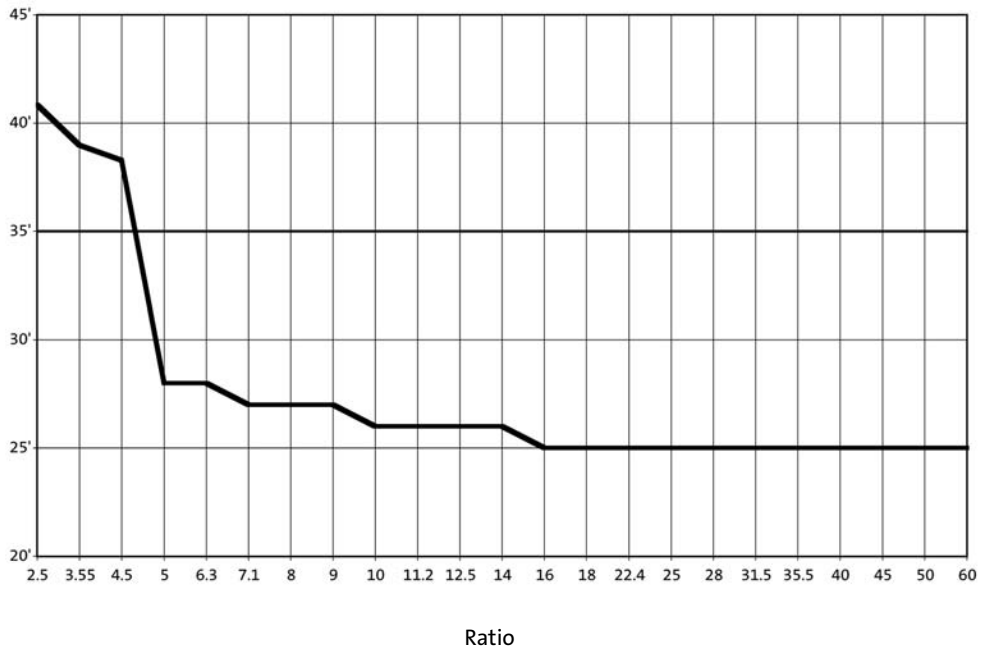

Ratio

GST04...09-1

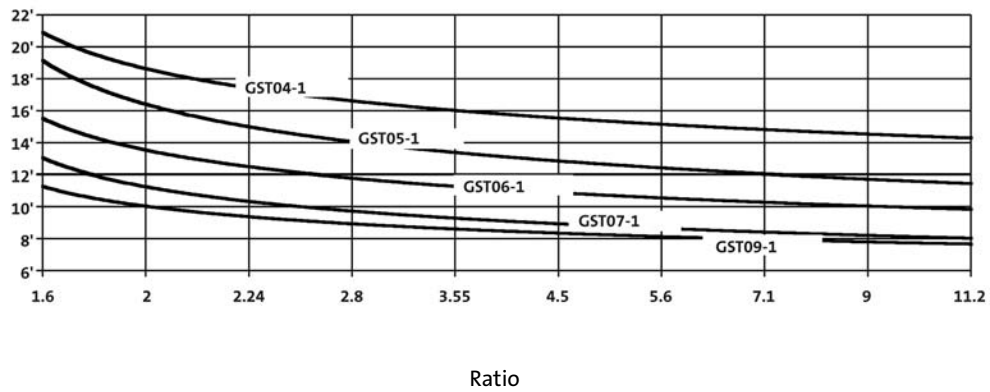

Ratio

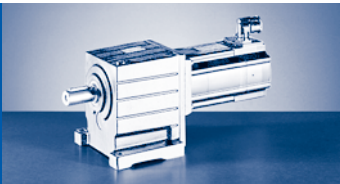

Output backlash in angular minutes

GST04...14-2

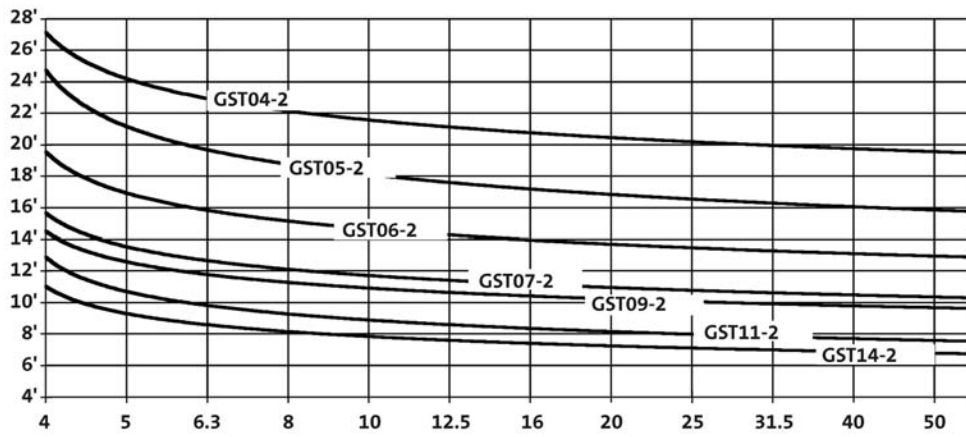

Ratio

GST05...14-3

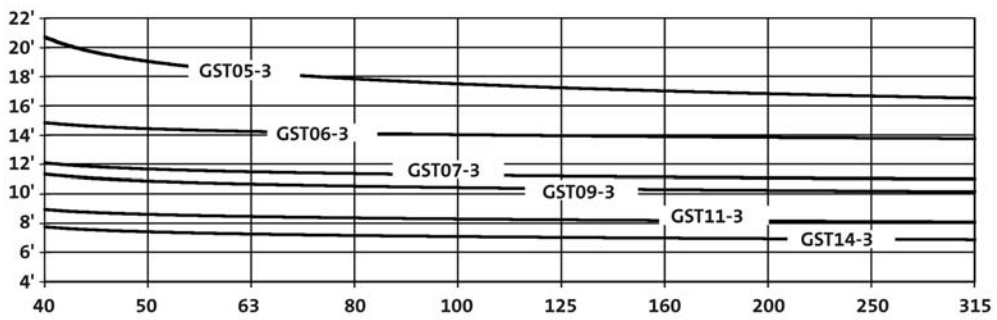

Ratio

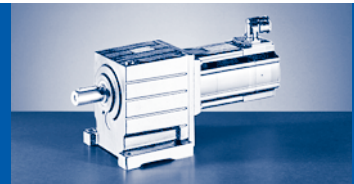

Position of ventilation, sealing elements and oil control

GST05...09-1

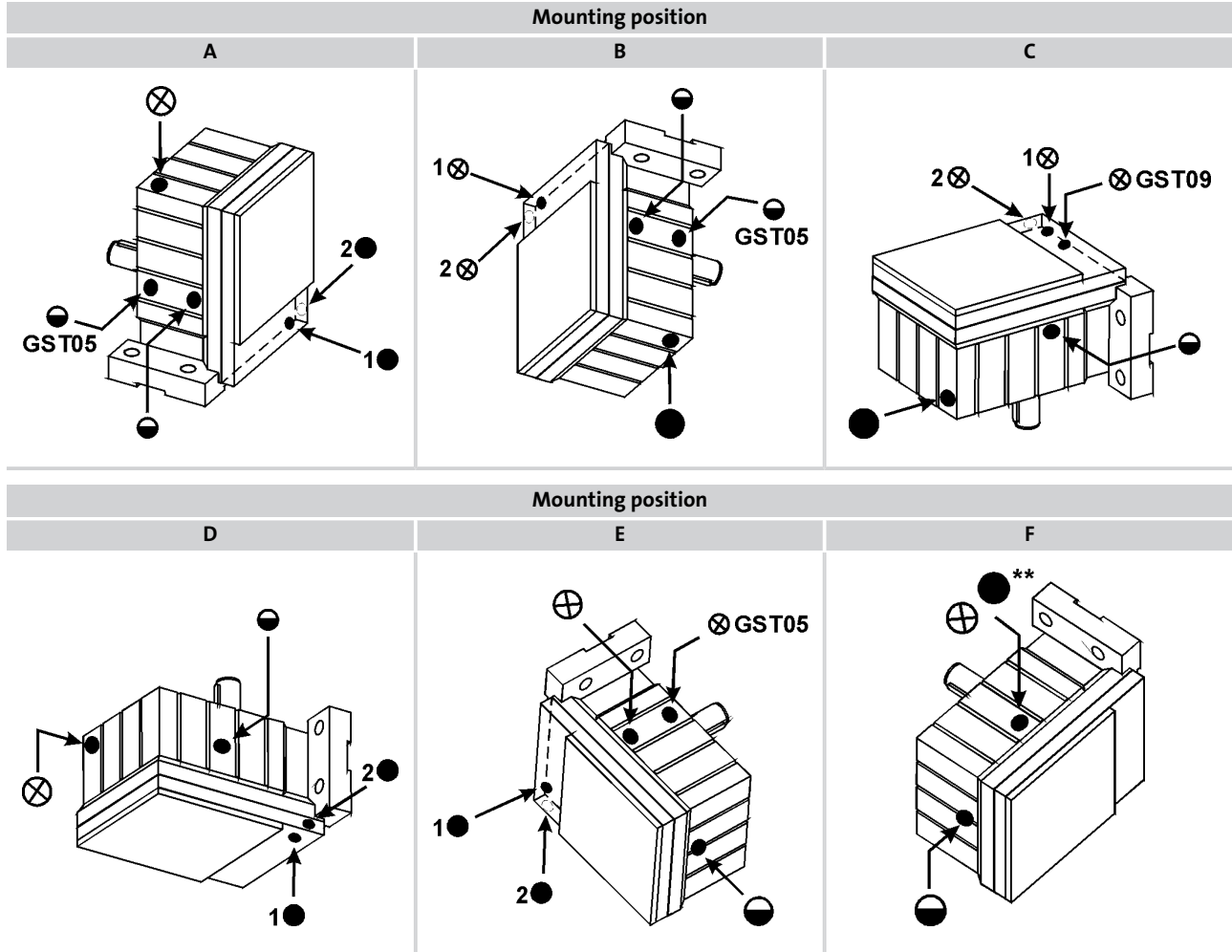

- ⊗ Ventilation/oil filler plug
- Oil drain plug
- ◐ Oil control plug
- \* On both sides
- \*\* Opposite

Pos.1 standard  
 Pos.2 only on GST05-1A □□□ 14LC□□

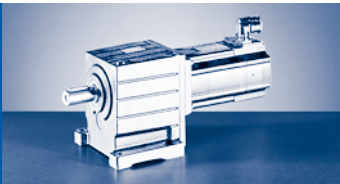

Position of ventilation, sealing elements and oil control

GST05...14-2

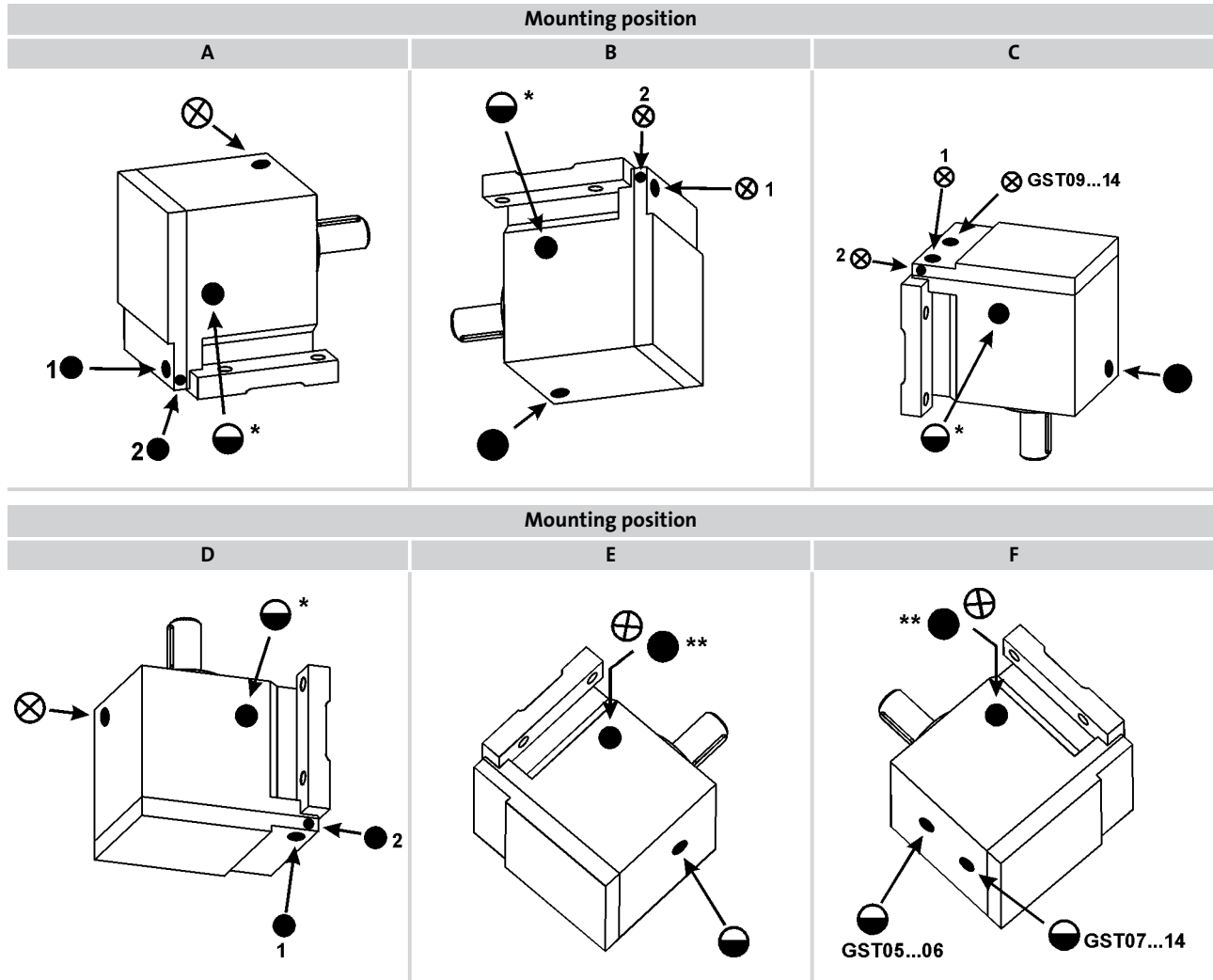

- ⊗ Ventilation/oil filler plug
- Oil drain plug
- Oil control plug
- \* On both sides
- \*\* Opposite

Pos.1 standard  
 Pos.2 only on GST05-2A □□□ 14LC□□

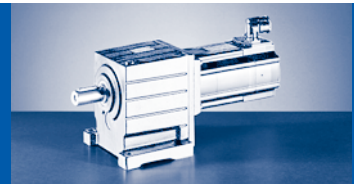

**Position of ventilation, sealing elements and oil control**

**GST05...14-3**

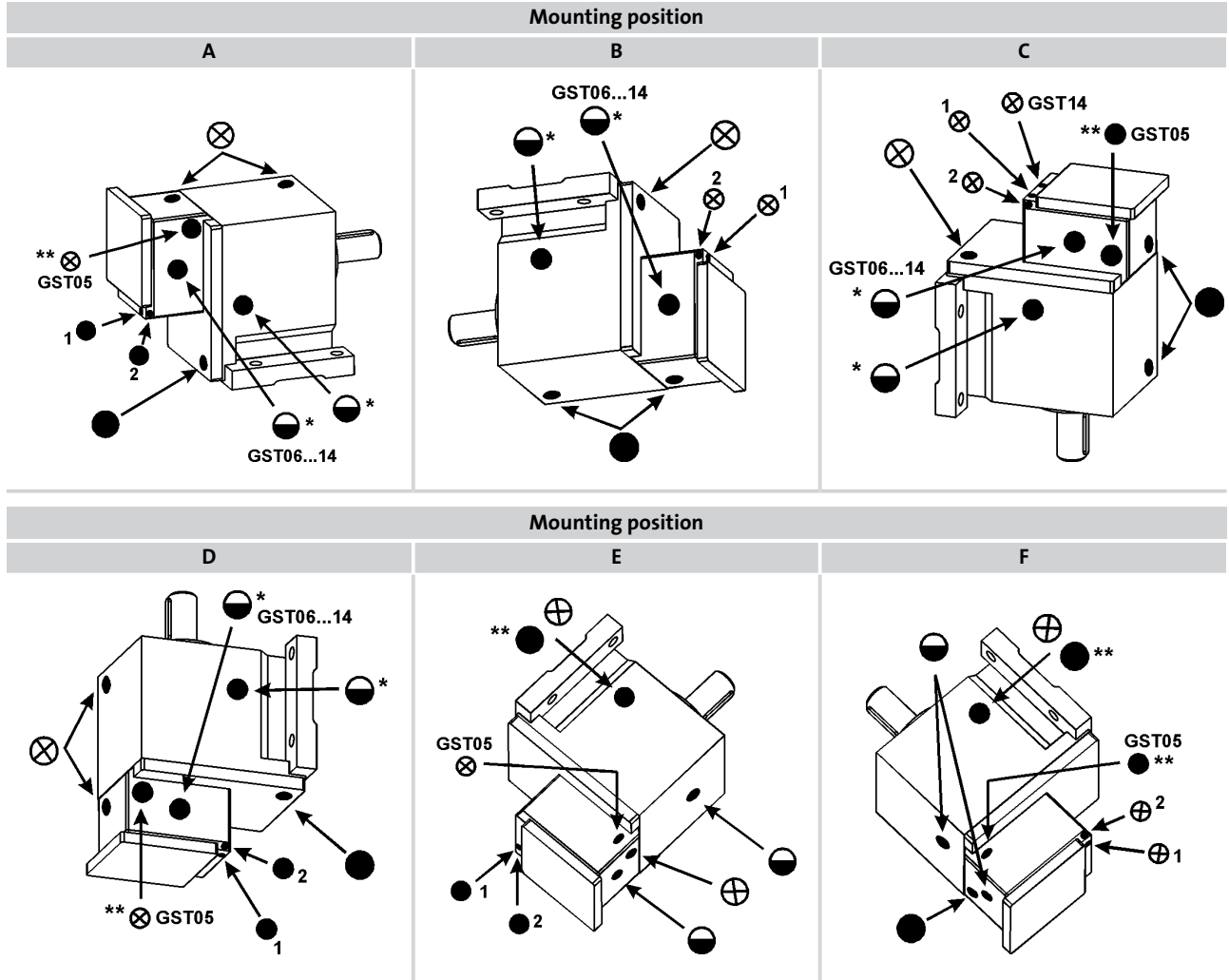

- ⊗ Ventilation/oil filler plug
- Oil drain plug
- ◐ Oil control plug
- \* On both sides
- \*\* Opposite

Pos.1 standard  
 Pos.2 only on GST07-3A □□□ 14LC□□

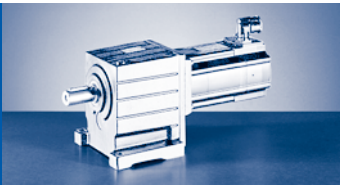

Compensation reservoir for mounting position C

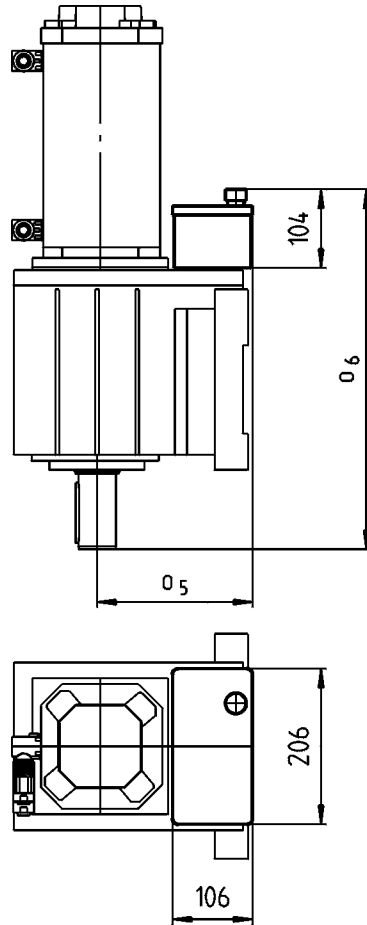

GST□□-2A...		14LC□□ <sup>1)</sup>	17NC□□ <sup>1)</sup>	19SC□□ <sup>1)</sup>	21XC□□ <sup>1)</sup>	GST□□-2S...		12□C□□	14□C□□	19□C□□
GST09...	o <sub>5</sub>	206		226	245	GST09...	o <sub>5</sub>	206		245
	o <sub>6</sub>	477					o <sub>6</sub>	477		
GST11...	o <sub>5</sub>	208		230	254	GST11...	o <sub>5</sub>	208		254
	o <sub>6</sub>	536		540			o <sub>6</sub>	536		540
GST14...	o <sub>5</sub>			252	282	GST14...	o <sub>5</sub>			282
	o <sub>6</sub>			640			o <sub>6</sub>			640

<sup>1)</sup> Connector/terminal box position 4 is not permitted.

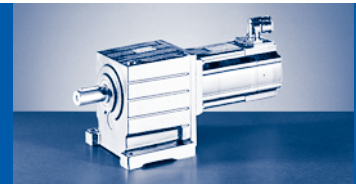

**GST□□-1S VBR...RSO B0**

	06C C41	06F C41	06I C41	09D C41	09F C38	09H C41	09L C41	12D C20	12D C41	12H C15	12H C30	12H C35	12L C20	12L C41
GST04...	7		8		10		11	13						
GST05...	9		10		12		13		15			18		21
GST06...	14		15		16	17	18	20		19		23		26
GST07...				26	27	28	30			29		32		35
GST09...									45		48			51

	14D C15	14D C36	14H C15	14H C32	14L C15	14L C32	14P C14	14P C32	19F C14	19F C30	19J C14	19J C30	19P C14	19P C30
GST06...	25		29		34		39							
GST07...	34		39		44		49		51		58			68
GST09...	50		55		59		64		66		73			83

**GST□□-1S VCR...RSO B0**

	06C C41	06F C41	06I C41	09D C41	09F C38	09H C41	09L C41	12D C20	12D C41	12H C15	12H C30	12H C35	12L C20	12L C41
GST04...	6		7	9	10	11	13							
GST05...	8		9		11	12		14				17		20
GST06...	12		13		15	16		18				21		24
GST07...				23	24	25	27		26			29		32
GST09...									40		43			47

	14D C15	14D C36	14H C15	14H C32	14L C15	14L C32	14P C14	14P C32	19F C14	19F C30	19J C14	19J C30	19P C14	19P C30
GST06...	23		28		32		37							
GST07...	31		36		41		46		48		55			65
GST09...	45		50		55		60		62		69			79

Note additional weights.  
Weights in [kg] with oil capacity for mounting position A, all given as approximate values

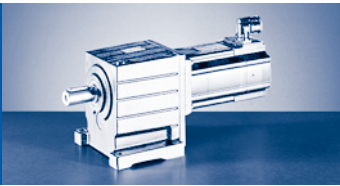

# GST [kg]

## GST□□-2S VAR/VBR...RSO B0

	06C C41	06F C41	06I C41	09D C41	09F C38	09H C41	09L C41	12D C20	12D C41	12H C15	12H C30	12H C35	12L C20	12L C41
GST03...	4	5	6											
GST04...	9		10	11	12	13	15							
GST05...	12	13		15	16	17	19	18		22			25	
GST06...	20	21		23	24	25		26		29			32	
GST07...				38	39	40	42	41		44			48	
GST09...								69		72			76	

	14D C15	14D C36	14H C15	14H C32	14L C15	14L C32	14P C14	14P C32	19F C14	19F C30	19J C14	19J C30	19P C14	19P C30
GST06...	31		36		40		45							
GST07...	47		51		56		61		63		70		80	
GST09...	75		79		84		89		91		98		108	
GST11...	121		126		130		135		137		144		154	
GST14...								227		234		244		

## GST□□-2S VCR...RSO B0

	06C C41	06F C41	06I C41	09D C41	09F C38	09H C41	09L C41	12D C20	12D C41	12H C15	12H C30	12H C35	12L C20	12L C41
GST03...	4	5												
GST04...	8		9	11	12	13	14							
GST05...	11	12		14		15		17		20			23	
GST06...	18	19		20	21	22	24	23		26			29	
GST07...				34	35	36		37		40			43	
GST09...								61		64			67	

	14D C15	14D C36	14H C15	14H C32	14L C15	14L C32	14P C14	14P C32	19F C14	19F C30	19J C14	19J C30	19P C14	19P C30
GST06...	28		33		38		42							
GST07...	42		47		52		56		59		66		76	
GST09...	66		71		75		80		82		89		99	
GST11...	106		111		115		120		122		129		139	
GST14...								199		206		216		

Note additional weights.

Weights in [kg] with oil capacity for mounting position A, all given as approximate values

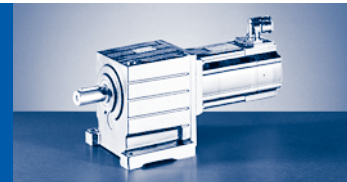

**GST□□-3S VAR/VBR...RSO B0**

	06C C41	06F C41	06I C41	09D C41	09F C38	09H C41	09L C41	12D C20	12D C41	12H C15	12H C30	12H C35	12L C20	12L C41
GST05...	15		16	18		19	21							
GST06...	25		26	28		29	31							
GST07...	43		44	45	46	47	49			52		55		
GST09...	75	76		78	79	80	82	81		84		87		
GST11...				133		134	136			139		142		
GST14...							243			246		249		

	14D C15	14D C36	14H C15	14H C32	14L C15	14L C32	14P C14	14P C32	19F C14	19F C30	19J C14	19J C30	19P C14	19P C30
GST09...	86		91		95		100							
GST11...	141		146		150		155		158		165		175	
GST14...	248		253		257		262		264		271		281	

**GST□□-3S VCR...RSO B0**

	06C C41	06F C41	06I C41	09D C41	09F C38	09H C41	09L C41	12D C20	12D C41	12H C15	12H C30	12H C35	12L C20	12L C41
GST05...	13		14	16	17	18	20							
GST06...	22		23	25	26	27	28							
GST07...	38	39		41	42	43	45	44		47		51		
GST09...	67		68	69	70	71	73	72		76		79		
GST11...				118	119		121			124		127		
GST14...							215			218		221		

	14D C15	14D C36	14H C15	14H C32	14L C15	14L C32	14P C14	14P C32	19F C14	19F C30	19J C14	19J C30	19P C14	19P C30
GST09...	78		82		87		92							
GST11...	126		131		135		140		143		150		160	
GST14...	220		225		229		234		236		243		253	

Note additional weights.  
Weights in [kg] with oil capacity for mounting position A, all given as approximate values

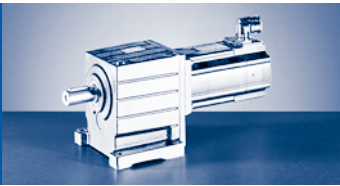

## GST [kg]

### GST□□-1A VBR...RSO B0

	10I C40 ...S00	13I C41 ...S00	13I C34 ...F10	14L C20 ...S00	14L C41 ...S00	14L C16 ...F10	14L C35 ...F10	17N C23 ...S00	17N C41 ...S00
GST04...	10	15	16						
GST05...	14	18	20	24		26			
GST06...	18	22	24	29		30		36	
GST07...	28	32	33	38		40		45	
GST09...				52		54		60	

	17N C17 ...F10	17N C35 ...F10	19S C23 ...S00	19S C42 ...S00	19S C17 ...F10	19S C35 ...F10	21X C25 ...S00	21X C42 ...S00	21X C17 ...F10	21X C35 ...F10
GST06...	39									
GST07...	48		69		72		86		89	
GST09...	63		83		86		101		104	

### GST□□-1A VCR...RSO B0

	10I C40 ...S00	13I C41 ...S00	13I C34 ...F10	14L C20 ...S00	14L C41 ...S00	14L C16 ...F10	14L C35 ...F10	17N C23 ...S00	17N C41 ...S00
GST04...	10	14	16						
GST05...	13	17	19	23		25			
GST06...	17	21	22	27		29		35	
GST07...	25	29	30	35		36		42	
GST09...				48		50		56	

	17N C17 ...F10	17N C35 ...F10	19S C23 ...S00	19S C42 ...S00	19S C17 ...F10	19S C35 ...F10	21X C25 ...S00	21X C42 ...S00	21X C17 ...F10	21X C35 ...F10
GST06...	37									
GST07...	45		66		69		83		86	
GST09...	58		78		82		96		100	

Note additional weights.

Weights in [kg] with oil capacity for mounting position A, all given as approximate values

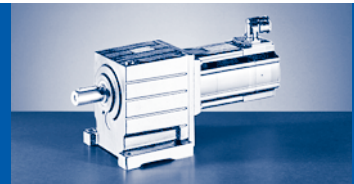

## GST□□-2A VAR/VBR...RSO B0

	10I C40 ...S00	13I C41 ...S00	13I C34 ...F10	14L C20 ...S00	14L C41 ...S00	14L C16 ...F10	14L C35 ...F10	17N C23 ...S00	17N C41 ...S00
GST04...	12	17	18						
GST05...	18	22	23		27		29		
GST06...	25	29	30		35		37		43
GST07...	40	44	46		50		52		58
GST09...					77		79		85
GST11...					123		125		131
GST14...									

	17N C17 ...F10	17N C35 ...F10	19S C23 ...S00	19S C42 ...S00	19S C17 ...F10	19S C35 ...F10	21X C25 ...S00	21X C42 ...S00	21X C17 ...F10	21X C35 ...F10
GST06...	45									
GST07...	60		81		84		98		101	
GST09...	87		107		111		125		129	
GST11...	133		153		156		170		173	
GST14...			245		248		259		263	

## GST□□-2A VCR...RSO B0

	10I C40 ...S00	13I C41 ...S00	13I C34 ...F10	14L C20 ...S00	14L C41 ...S00	14L C16 ...F10	14L C35 ...F10	17N C23 ...S00	17N C41 ...S00
GST04...	12	16	18						
GST05...	16	20	22		26		28		
GST06...	22	26	28		32		34		40
GST07...	36	40	41		45		47		53
GST09...					68		70		76
GST11...					108		110		116
GST14...									

	17N C17 ...F10	17N C35 ...F10	19S C23 ...S00	19S C42 ...S00	19S C17 ...F10	19S C35 ...F10	21X C25 ...S00	21X C42 ...S00	21X C17 ...F10	21X C35 ...F10
GST06...	43									
GST07...	56		77		80		93		97	
GST09...	79		99		102		117		120	
GST11...	118		138		141		155		158	
GST14...			217		220		231		235	

Note additional weights.

Weights in [kg] with oil capacity for mounting position A, all given as approximate values

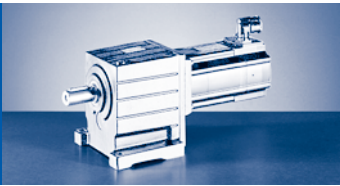

## GST [kg]

### GST□□-3A VAR/VBR...RSO B0

	10I C40 ...S00	13I C41 ...S00	13I C34 ...F10	14L C20 ...S00	14L C41 ...S00	14L C16 ...F10	14L C35 ...F10	17N C23 ...S00	17N C41 ...S00
GST05...	18	23	25						
GST06...	28	33	35						
GST07...	48	52	54	58		60			
GST09...	80	84	85	90		92		98	
GST11...	134	138	140	144		146		152	
GST14...				250		252		258	

	17N C17 ...F10	17N C35 ...F10	19S C23 ...S00	19S C42 ...S00	19S C17 ...F10	19S C35 ...F10	21X C25 ...S00	21X C42 ...S00	21X C17 ...F10	21X C35 ...F10
GST09...	100									
GST11...	155		175		179		192		196	
GST14...	261		281		284		299		302	

### GST□□-3A VCR...RSO B0

	10I C40 ...S00	13I C41 ...S00	13I C34 ...F10	14L C20 ...S00	14L C41 ...S00	14L C16 ...F10	14L C35 ...F10	17N C23 ...S00	17N C41 ...S00
GST05...	17	21	23						
GST06...	26	30	32						
GST07...	44	48	49	53		55			
GST09...	71	75	77	82		83		89	
GST11...	119	123	125	129		131		137	
GST14...				222		224		230	

	17N C17 ...F10	17N C35 ...F10	19S C23 ...S00	19S C42 ...S00	19S C17 ...F10	19S C35 ...F10	21X C25 ...S00	21X C42 ...S00	21X C17 ...F10	21X C35 ...F10
GST09...	92									
GST11...	140		160		164		177		181	
GST14...	233		253		256		271		274	

Note additional weights.  
Weights in [kg] with oil capacity for mounting position A, all given as approximate values

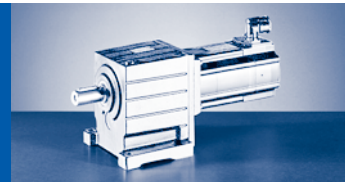

**Additional weights MCS servo motors**

	06C C41	06F C41	06I C41	09D C41	09F C38	09H C41	09L C41	12D C20	12D C41	12H C15	12H C30	12H C35	12L C20	12L C41
...P1	0.3			0.8				0.9						
...P2				0.5				1.2						
...SCS/SCM/SRM/SRS ...ECN/EQN	0.4			0.2				0.3						

	14D C15	14D C36	14H C15	14H C32	14L C15	14L C32	14P C14	14P C32	19F C14	19F C30	19J C14	19J C30	19P C14	19P C30
...P1	1.9							1.5						
...P2	3.1									4.3				
...SCS/SCM/SRM/SRS ...ECN/EQN								0.3						

**Additional weights MCA servo motors**

	10I C40 ...S00	13I C41 ...S00	13I C34 ...F10	14L C20 ...S00	14L C41 ...S00	14L C16 ...F10	14L C35 ...F10	17N C23 ...S00	17N C41 ...S00
...P1/P5								2.4	
...P2/P6	0.8	1.4		1.5					
...CDD ...ECN/EQN/EQI ...SCS/SCM/SRM/SRS/S20 ...T20	0.3	0.5		0.6			0.7		

  

	17N C17 ...F10	17N C35 ...F10	19S C23 ...S00	19S C42 ...S00	19S C17 ...F10	19S C35 ...F10	21X C25 ...S00	21X C42 ...S00	21X C17 ...F10	21X C35 ...F10
...P1/P5	2.4		4.8			5.0				
...P2/P6										
...CDD ...ECN/EQN/EQI ...SCS/SCM/SRM/SRS/S20 ...T20	0.7		1.0			1.1				

**Additional weights gearbox**

	Flange
	VAL/VCK
GST03...	0.8
GST04...	1.0
GST05...	1.5
GST06...	3.0
GST07...	4.0
GST09...	7.0
GST11...	10.5
GST14...	15.5

Weights in [kg]

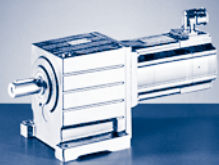

# GST [ i ]

►  $i_g = z_g / z_t$

	<b>i</b>	<b>z<sub>g</sub></b>	<b>z<sub>t</sub></b>
<b>GST03-2</b>	2.597	896	345
	3.413	1280	375
	4.368	1376	315
	5.312	1344	253
	5.965	1372	230
	6.982	1920	275
	7.840	1960	250
	8.935	2064	231
	10.033	2107	210
	11.429	2640	231
	12.833	2695	210
	14.836	2448	165
	16.660	2499	150
	19.013	2928	154
	21.350	2989	140
	24.595	2976	121
	27.618	3038	110
	32.000	3168	99
	35.933	3234	90
	41.455	4560	110
46.550	4655	100	
52.909	4656	88	
59.413	4753	80	
<b>GST04-1</b>	1.600	40	25
	2.048	43	21
	2.240	56	25
	2.857	60	21
	3.500	63	18
	4.400	66	15
	5.667	68	12
	7.182	79	11
	9.000	81	9
	11.857	83	7
<b>GST04-2</b>	2.956	1330	450
	3.333	1400	420
	4.053	1520	375
	4.571	1600	350
	5.187	1634	315
	5.850	1720	294
	6.400	2240	350
	7.040	1760	250
	8.000	1800	225
	9.010	1892	210
	9.856	2464	250
	11.200	2520	225

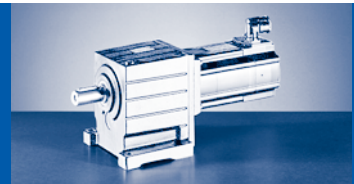

▶  $i_g = z_g / z_t$

	i	$z_g$	$z_t$
GST04-2	12.571	2640	210
	14.286	2700	189
	15.400	2772	180
	17.500	2835	162
	19.360	2904	150
	22.000	2970	135
	24.933	2992	120
	28.333	3060	108
	31.600	3476	110
	35.909	3555	99
	39.600	3564	90
	45.000	3645	81
	52.171	3652	70
	59.286	3735	63
GST05-1	1.600	40	25
	2.048	43	21
	2.240	56	25
	2.857	60	21
	3.500	63	18
	4.556	82	
	5.667	68	12
	7.333	88	
	8.900	89	
	11.375	91	8
	GST05-2	2.956	1330
3.333		1400	420
4.053		1520	375
4.571		1600	350
5.187		1634	315
5.850		1720	294
6.400		2240	350
7.238		2280	315
8.163		2400	294
9.010		1892	210
10.000		2520	252
11.200			225
13.016		3280	252
14.356		2584	180
16.190		2720	168
17.500		2835	162
20.044		3608	180
22.778		3690	162
24.933		2992	120
28.333		3060	108
32.267	3872	120	

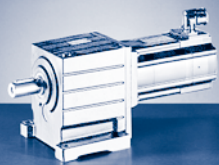

# GST [ i ]

►  $i_g = z_g / z_t$

	<b>i</b>	<b>z<sub>g</sub></b>	<b>z<sub>t</sub></b>
<b>GST05-2</b>	36.667	3960	108
	39.160	3916	100
	44.500	4005	90
	50.050	4004	80
	56.875	4095	72
<b>GST05-3</b>	36.267	152320	4200
	46.259	163200	3528
	56.667	171360	3024
	63.467		2700
	71.238	179520	2520
	80.952	183600	2268
	91.746	184960	2016
	99.167	192780	1944
	116.277	214880	1848
	124.667	201960	1620
	145.714	220320	1512
	160.556	208080	1296
	179.067	236368	1320
	191.973	225760	1176
	224.400	242352	1080
	255.000	247860	972
	295.638	248336	840
335.952	253980	756	
<b>GST06-1</b>	1.600	40	25
	2.048	43	21
	2.240	56	25
	2.857	60	21
	3.500	63	18
	4.556	82	
	5.667	68	12
	7.333	88	10
	8.900	89	
	11.250	90	
<b>GST06-2</b>	3.033	1365	450
	3.333	1400	420
	4.160	1560	375
	4.571	1600	350
	5.324	1677	315
	5.850	1720	294
	6.400	2240	350
	7.040	1760	250
	8.163	2400	294
	9.010	1892	210
	10.000	2520	252
	11.200		225

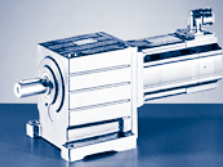

▶  $i_g = z_g / z_t$

	<b>i</b>	<b>z<sub>g</sub></b>	<b>z<sub>t</sub></b>
<b>GST06-2</b>	12.571	2640	210
	14.286	2700	189
	15.400	2772	180
	17.500	2835	162
	20.044	3608	180
	22.778	3690	162
	24.933	2992	120
	28.333	3060	108
	32.267	3872	120
	36.667	3960	108
	39.160	3916	100
	44.500	4005	90
	49.500	3960	80
	56.250	4050	72
<b>GST06-3</b>	39.200	158760	4050
	44.000	166320	3780
	51.022	206640	4050
	53.900	174636	3240
	67.760	182952	2700
	70.156	227304	3240
	80.952	183600	2268
	87.267	188496	2160
	99.167	192780	1944
	109.707	197472	1800
	124.667	201960	1620
	141.289	203456	1440
	160.556	208080	1296
	179.067	236368	1320
	203.485	241740	1188
	231.733	305888	1320
	255.000	247860	972
	290.400	313632	1080
	330.000	320760	972
	382.590	321376	840
434.762	328680	756	
<b>GST07-1</b>	1.625	39	24
	2.000	42	21
	2.240	56	25
	2.857	60	21
	3.500	63	18
	4.556	82	
	5.583	67	12
	7.333	88	
	8.900	89	10
	11.250	90	8

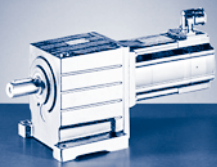

# GST [ i ]

►  $i_g = z_g / z_t$

	<b>i</b>	<b>z<sub>g</sub></b>	<b>z<sub>t</sub></b>
<b>GST07-2</b>	3.048	1326	435
	3.350	1360	406
	4.225	1521	360
	4.643	1560	336
	5.200	1638	315
	5.714	1680	294
	6.400	2240	350
	7.150	1716	240
	8.125	1755	216
	8.800	1848	210
	9.856	2464	250
	11.200	2520	225
	12.571	2640	210
	14.286	2700	189
	15.400	2772	180
	17.500	2835	162
	20.044	3608	180
	22.778	3690	162
	24.567	2948	120
	27.917	3015	108
	32.267	3872	120
	36.667	3960	108
	39.160	3916	100
	44.500	4005	90
49.500	3960	80	
56.250	4050	72	
<b>GST07-3</b>	39.200	158760	4050
	44.000	166320	3780
	51.022	206640	4050
	53.900	174636	3240
	65.079	221400	3402
	70.156	227304	3240
	79.762	180900	2268
	85.983	185724	2160
	97.708	189945	1944
	111.915	241736	2160
	127.176	247230	1944
	139.211	200464	1440
	158.194	205020	1296
	180.156	259424	1440
	204.722	265320	1296
	236.622	340736	1440
	248.458	268335	1080
	268.889	348480	1296
326.333	352440	1080	



►  $i_g = z_g / z_t$

	i	$z_g$	$z_t$
GST07-3	367.033	352352	960
	417.083	360360	864
GST09-1	1.560	39	25
	2.048	43	21
	2.333	56	24
	2.810	59	21
	3.444	62	18
	4.667	84	
	5.667	68	12
	7.333	88	
	8.900	89	10
	11.250	90	8
GST09-2	4.056	1521	375
	4.457	1560	350
	5.324	1677	315
	5.850	1720	294
	6.667	2240	336
	7.305	2301	315
	8.027	2360	294
	9.010	1892	210
	10.267	2464	240
	11.667	2520	216
	12.362	2596	210
	14.048	2655	189
	15.156	2728	180
	17.222	2790	162
	20.533	3696	180
	23.333	3780	162
	24.933	2992	120
	28.333	3060	108
	32.267	3872	120
	36.667	3960	108
39.160	3916	100	
44.500	4005	90	
49.500	3960	80	
56.250	4050	72	
GST09-3	40.136	159300	3969
	43.267	163548	3780
	49.167	167265	3402
	53.044	171864	3240
	60.278	175770	2916
	71.867	232848	3240
	81.667	238140	2916
	93.541	303072	3240
99.167	192780	1944	

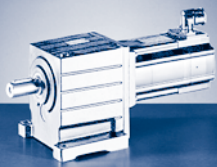

# GST [ i ]

▶  $i_g = z_g / z_t$

	<b>i</b>	<b>z<sub>g</sub></b>	<b>z<sub>t</sub></b>
<b>GST09-3</b>	113.585	245344	2160
	129.074	250920	1944
	141.289	203456	1440
	160.556	208080	1296
	182.844	263296	1440
	207.778	269280	1296
	236.622	340736	1440
	252.167	272340	1080
	268.889	348480	1296
	326.333	352440	1080
	363.000	348480	960
	412.500	356400	864
<b>GST11-2</b>	4.056	1521	375
	4.457	1560	350
	5.324	1677	315
	5.850	1720	294
	6.400	2240	350
	6.864	1716	250
	7.800	1755	225
	9.010	1892	210
	9.856	2464	250
	11.200	2520	225
	12.571	2640	210
	14.286	2700	189
	15.400	2772	180
	17.500	2835	162
	20.289	3652	180
	23.056	3735	162
	24.933	2992	120
	28.333	3060	108
	32.267	3872	120
	36.667	3960	108
39.160	3916	100	
44.500	4005	90	
49.500	3960	80	
56.250	4050	72	
<b>GST11-3</b>	40.816	162000	3969
	44.000	166320	3780
	50.000	170100	3402
	57.968	219120	3780
	61.250	178605	2916
	71.011	230076	3240
	80.694	235305	2916
	87.267	188496	2160
99.167	192780	1944	

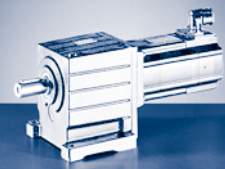

▶  $i_g = z_g / z_t$

	i	$z_g$	$z_t$
GST11-3	112.933	243936	2160
	129.074	250920	1944
	146.993	317504	2160
	158.194	205020	1296
	180.156	259424	1440
	207.778	269280	1296
	236.622	340736	1440
	252.167	272340	1080
	268.889	348480	1296
	326.333	352440	1080
	363.000	348480	960
	412.500	356400	864
GST14-2	4.225	1521	360
	4.643	1560	336
	5.200	1638	315
	5.714	1680	294
	6.286	2200	350
	7.150	1716	240
	8.027	2360	294
	8.800	1848	210
	9.841	2480	252
	11.000	2475	225
	12.362	2596	210
	14.048	2655	189
	15.156	2728	180
	17.222	2790	162
	20.044	3608	180
	22.778	3690	162
	24.567	2948	120
	27.917	3015	108
	32.267	3872	120
	36.667	3960	108
39.160	3916	100	
44.500	4005	90	
49.500	3960	80	
56.250	4050	72	
GST14-3	40.185	156240	3888
	42.580	160952	3780
	48.386	164610	3402
	53.148	206640	3888
	59.321	172980	2916
	69.042	223696	3240
	78.457	228780	2916
	93.541	303072	3240
96.157	186930	1944	

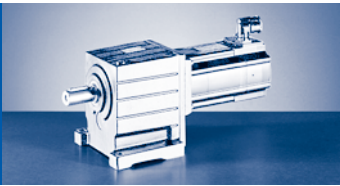

# GST [ i ]

▶  $i_g = z_g / z_t$

	<b>i</b>	<b>z<sub>g</sub></b>	<b>z<sub>t</sub></b>
<b>GST14-3</b>	<b>106.296</b>	309960	2916
	<b>130.278</b>	253260	1944
	<b>139.211</b>	200464	1440
	<b>158.194</b>	205020	1296
	<b>171.111</b>	332640	1944
	<b>204.722</b>	265320	1296
	<b>236.622</b>	340736	1440
	<b>248.458</b>	268335	1080
	<b>268.889</b>	348480	1296
	<b>326.333</b>	352440	1080
	<b>363.000</b>	348480	960
	<b>412.500</b>	356400	864

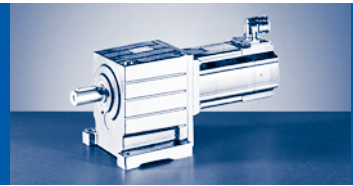

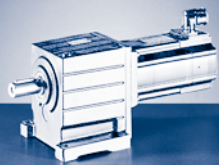

# GST [Nm]

## GST□□-□S (MCS)

$M_{2GN} \leq 45 \text{ Nm}$

GST03-2S				06CC41	06FC41	06IC41
				...500	...500	...500
i	$M_{2GN}$	$J_G$	$M_1$			
			$n_1$	4050	4050	4050
			$I_{M230}$	2.6	2.9	3.2
			$I_{M400}$	1.3	1.5	1.6
			$P_N$	0.25	0.51	0.64
			$J_M$	0.17	0.25	0.33
2.597	18	0.26	$M_2$		3	4
			c		4.3	3.4
			$n_{2 \text{ Eck}}$		1559	1559
			$n_{2 \text{ th}}$		1559	1559
3.413	19	0.17	$M_2$		4	5
			c		3.5	2.8
			$n_{2 \text{ Eck}}$		1187	1187
			$n_{2 \text{ th}}$		1187	1187
4.368	21	0.12	$M_2$	2	5	6
			c	5.9	3.0	2.4
			$n_{2 \text{ Eck}}$	927	927	927
			$n_{2 \text{ th}}$	927	927	927
5.312	27	0.18	$M_2$		6	8
			c		3.1	2.5
			$n_{2 \text{ Eck}}$		762	762
			$n_{2 \text{ th}}$		762	740
5.965	29	0.17	$M_2$	3	7	9
			c	5.9	3.0	2.4
			$n_{2 \text{ Eck}}$	679	679	679
			$n_{2 \text{ th}}$	679	679	653
6.982	30	0.12	$M_2$	4	8	10
			c	5.2	2.6	2.1
			$n_{2 \text{ Eck}}$	580	580	580
			$n_{2 \text{ th}}$	580	580	580
7.840	32	0.12	$M_2$	4	9	11
			c	5.0	2.5	2.0
			$n_{2 \text{ Eck}}$	517	517	517
			$n_{2 \text{ th}}$	517	517	517
8.935	33	0.09	$M_2$	5	10	13
			c	4.5	2.3	1.8
			$n_{2 \text{ Eck}}$	453	453	453
			$n_{2 \text{ th}}$	453	453	453
10.033	35	0.09	$M_2$	6	12	14
			c	4.3	2.1	1.7
			$n_{2 \text{ Eck}}$	404	404	404
			$n_{2 \text{ th}}$	404	404	404
11.429	35	0.06	$M_2$	7	13	17
			c	3.8	1.9	1.5
			$n_{2 \text{ Eck}}$	354	354	354
			$n_{2 \text{ th}}$	354	354	354
12.833	38	0.06	$M_2$	7	15	19
			c	3.6	1.8	1.5
			$n_{2 \text{ Eck}}$	316	316	316
			$n_{2 \text{ th}}$	316	316	316
14.836	39	0.04	$M_2$	8	17	22
			c	3.2	1.6	1.3
			$n_{2 \text{ Eck}}$	273	273	273
			$n_{2 \text{ th}}$	273	273	273
16.660	41	0.04	$M_2$	10	19	24
			c	3.5	1.7	1.4
			$n_{2 \text{ Eck}}$	243	243	243
			$n_{2 \text{ th}}$	243	243	243

$M \dots$  [Nm]  
 $n \dots$  [r/min]  
 $J \dots$  [kgcm<sup>2</sup>]

$P \dots$  [kW]  
 $I \dots$  [A]  
 $i \dots$  [-]  
 $c \dots$  [-]

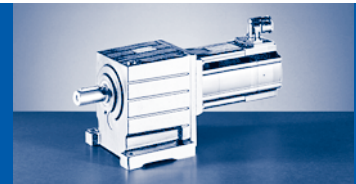

$M_{2GN} \leq 45 \text{ Nm}$

GST03-2S				06CC41	06FC41	06IC41
				...500	...500	...500
i	$M_{2GN}$	$J_G$	$M_1$			
			$n_1$	4050	4050	4050
			$I_{M230}$	2.6	2.9	3.2
			$I_{M400}$	1.3	1.5	1.6
			$P_N$	0.25	0.51	0.64
			$J_M$	0.17	0.25	0.33
19.013	42	0.03	$M_2$	11	22	28
			c	3.1	1.5	1.2
			$n_{2 \text{ Eck}}$	213	213	213
			$n_{2 \text{ th}}$	213	213	213
21.350	44	0.03	$M_2$	12	25	31
			c	2.9	1.5	1.2
			$n_{2 \text{ Eck}}$	190	190	190
			$n_{2 \text{ th}}$	190	190	190
24.595	45	0.02	$M_2$	14	29	36
			c	2.6	1.3	1.0
			$n_{2 \text{ Eck}}$	165	165	165
			$n_{2 \text{ th}}$	165	165	165
27.618	45	0.02	$M_2$	16	32	
			c	2.3	1.1	
			$n_{2 \text{ Eck}}$	147	147	
			$n_{2 \text{ th}}$	147	147	
32.000	45	0.01	$M_2$	18		
			c	2.0		
			$n_{2 \text{ Eck}}$	127		
			$n_{2 \text{ th}}$	127		
35.933	45	0.01	$M_2$	21		
			c	1.8		
			$n_{2 \text{ Eck}}$	113		
			$n_{2 \text{ th}}$	113		

M ... [Nm]  
n ... [r/min]  
J ... [kgcm<sup>2</sup>]

P ... [kW]  
I ... [A]  
i [-]  
c [-]

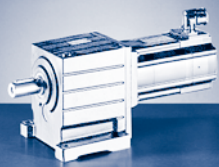

# GST [Nm]

## GST□□-□S (MCS)

$M_{2GN} \leq 25 \text{ Nm}$

GST04-1S				06CC41	06FC41	06IC41	09DC41	09FC38	09HC41	09LC41
				...500	...500	...500	...500	...500	...500	...500
i	$M_{2GN}$	$J_G$	$M_1$	0.60	1.20	1.50	2.30	3.10	3.80	4.50
			$n_1$	4050	4050	4050	4050	3750	4050	4050
			$I_{M230}$	2.6	2.9	3.2	4.6	5.0	6.8	8.4
			$I_{M400}$	1.3	1.5	1.6	2.3	2.5	3.4	4.2
			$P_N$	0.25	0.51	0.64	1.00	1.20	1.60	1.90
			$J_M$	0.17	0.25	0.33	1.13	1.53	1.93	2.83
1.600	19	0.27	$M_2$			2	4	5	6	7
			c			5.8	3.8	2.9	2.3	1.9
			$n_{2 \text{ Eck}}$			2531	2531	2344	2531	2531
			$n_{2 \text{ th}}$			2531	2380	2271	2179	2104
2.048	23	0.19	$M_2$			3	5	6	8	9
			c			5.4	3.5	2.7	2.1	1.8
			$n_{2 \text{ Eck}}$			1978	1978	1831	1978	1978
			$n_{2 \text{ th}}$			1978	1978	1831	1978	1867
2.240	25	0.17	$M_2$			3	5	7	8	10
			c			5.4	3.5	2.7	2.1	1.8
			$n_{2 \text{ Eck}}$			1808	1808	1674	1808	1808
			$n_{2 \text{ th}}$			1808	1808	1674	1808	1770
2.857	25	0.13	$M_2$		3	4	6	9	11	13
			c		5.3	4.3	2.8	2.1	1.7	1.4
			$n_{2 \text{ Eck}}$		1418	1418	1418	1313	1418	1418
			$n_{2 \text{ th}}$		1418	1418	1418	1313	1418	1418
3.500	25	0.10	$M_2$		4	5	8	11	13	15
			c		4.3	3.5	2.3	1.7	1.4	1.2
			$n_{2 \text{ Eck}}$		1157	1157	1157	1071	1157	1157
			$n_{2 \text{ th}}$		1157	1157	1157	1071	1157	1157
4.400	25	0.07	$M_2$		5	6				
			c		3.5	2.8				
			$n_{2 \text{ Eck}}$		921	921				
			$n_{2 \text{ th}}$		920	920				
5.667	25	0.05	$M_2$	3	7	8				
			c	5.4	2.7	2.1				
			$n_{2 \text{ Eck}}$	715	715	715				
			$n_{2 \text{ th}}$	715	715	715				

M ... [Nm]  
n ... [r/min]  
J ... [kgcm<sup>2</sup>]

P ... [kW]  
I ... [A]  
i [-]  
c [-]

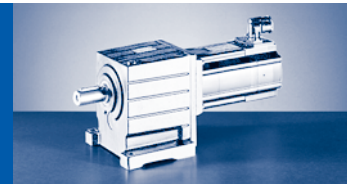

$M_{2GN} \leq 71 \text{ Nm}$

GST04-2S				06CC41	06FC41	06IC41	09DC41	09FC38	09HC41	09LC41
				...500	...500	...500	...500	...500	...500	...500
i	$M_{2GN}$	$J_G$	$M_1$	0.60	1.20	1.50	2.30	3.10	3.80	4.50
			$n_1$	4050	4050	4050	4050	3750	4050	4050
			$I_{M230}$	2.6	2.9	3.2	4.6	5.0	6.8	8.4
			$I_{M400}$	1.3	1.5	1.6	2.3	2.5	3.4	4.2
			$P_N$	0.25	0.51	0.64	1.00	1.20	1.60	1.90
			$J_M$	0.17	0.25	0.33	1.13	1.53	1.93	2.83
2.956	39	0.34	$M_2$				6	9	11	13
			c				4.3	3.2	2.6	2.2
			$n_{2 \text{ Eck}}$				1370	1269	1370	1370
			$n_{2 \text{ th}}$				1186	1127	1077	1041
3.333	42	0.32	$M_2$				7	10	12	14
			c				4.0	3.1	2.4	2.1
			$n_{2 \text{ Eck}}$				1215	1125	1215	1215
			$n_{2 \text{ th}}$				1041	989	945	912
4.053	45	0.31	$M_2$			6	9	12	15	18
			c			5.5	3.6	2.7	2.2	1.8
			$n_{2 \text{ Eck}}$			999	999	925	999	999
			$n_{2 \text{ th}}$			997	930	887	850	805
4.571	48	0.30	$M_2$			6	10	14	17	20
			c			5.2	3.4	2.6	2.0	1.7
			$n_{2 \text{ Eck}}$			886	886	820	886	886
			$n_{2 \text{ th}}$			876	816	778	746	694
5.187	50	0.22	$M_2$		6	7	11	15	19	23
			c		6.0	4.8	3.1	2.4	1.9	1.6
			$n_{2 \text{ Eck}}$		781	781	781	723	781	781
			$n_{2 \text{ th}}$		781	781	781	723	753	689
5.850	53	0.22	$M_2$		7	8	13	17	21	25
			c		5.6	4.5	2.9	2.2	1.8	1.5
			$n_{2 \text{ Eck}}$		692	692	692	641	692	692
			$n_{2 \text{ th}}$		692	692	692	641	648	594
6.400	55	0.19	$M_2$		7	9	14	19	23	28
			c		5.3	4.3	2.8	2.1	1.7	1.4
			$n_{2 \text{ Eck}}$		633	633	633	586	633	633
			$n_{2 \text{ th}}$		633	633	633	586	600	553
7.040	57	0.26	$M_2$		8	10	15	21	26	31
			c		5.0	4.0	2.6	2.0	1.6	1.3
			$n_{2 \text{ Eck}}$		575	575	575	533	575	575
			$n_{2 \text{ th}}$		565	545	506	482	431	400
8.000	59	0.26	$M_2$		9	11	18	24	29	35
			c		4.5	3.6	2.4	1.8	1.4	1.2
			$n_{2 \text{ Eck}}$		506	506	506	469	506	506
			$n_{2 \text{ th}}$		490	472	438	405	364	339
9.010	63	0.19	$M_2$		10	13	20	27	33	39
			c		4.3	3.4	2.2	1.7	1.4	1.1
			$n_{2 \text{ Eck}}$		450	450	450	416	450	450
			$n_{2 \text{ th}}$		450	450	450	412	368	341
9.856	65	0.17	$M_2$		11	14	22	29	36	43
			c		4.1	3.2	2.1	1.6	1.3	1.1
			$n_{2 \text{ Eck}}$		411	411	411	381	411	411
			$n_{2 \text{ th}}$		411	411	411	380	344	321
11.200	60	0.17	$M_2$		13	16	25	34	41	
			c		3.3	2.6	1.7	1.3	1.0	
			$n_{2 \text{ Eck}}$		362	362	362	335	362	
			$n_{2 \text{ th}}$		362	362	348	306	278	
12.571	69	0.13	$M_2$		14	18	28	38	46	
			c		3.4	2.7	1.8	1.4	1.1	
			$n_{2 \text{ Eck}}$		322	322	322	298	322	
			$n_{2 \text{ th}}$		322	322	322	298	291	

$M \dots$  [Nm]  
 $n \dots$  [r/min]  
 $J \dots$  [kgcm<sup>2</sup>]

$P \dots$  [kW]  
 $I \dots$  [A]  
 $i \dots$  [-]  
 $c \dots$  [-]

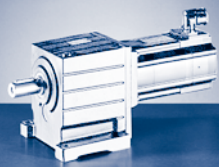

# GST [Nm]

## GST□□-□S (MCS)

$M_{2GN} \leq 71 \text{ Nm}$

GST04-2S				06CC41	06FC41	06IC41	09DC41	09FC38	09HC41	09LC41
				...500	...500	...500	...500	...500	...500	...500
i	$M_{2GN}$	$J_G$	$M_1$	0.60	1.20	1.50	2.30	3.10	3.80	4.50
			$n_1$	4050	4050	4050	4050	3750	4050	4050
			$I_{M230}$	2.6	2.9	3.2	4.6	5.0	6.8	8.4
			$I_{M400}$	1.3	1.5	1.6	2.3	2.5	3.4	4.2
			$P_N$	0.25	0.51	0.64	1.00	1.20	1.60	1.90
			$J_M$	0.17	0.25	0.33	1.13	1.53	1.93	2.83
14.286	61	0.12	$M_2$	8	16	21	32	43		
			c	5.3	2.6	2.1	1.4	1.0		
			$n_{2 \text{ Eck}}$	284	284	284	284	263		
			$n_{2 \text{ th}}$	284	284	284	280	254		
15.400	70	0.10	$M_2$		18	22	34	46	57	
			c		3.2	2.5	1.7	1.3	1.0	
			$n_{2 \text{ Eck}}$		263	263	263	244	263	
			$n_{2 \text{ th}}$		263	263	263	244	263	
17.500	62	0.10	$M_2$	10	20	25	39			
			c	4.9	2.5	2.0	1.3			
			$n_{2 \text{ Eck}}$	231	231	231	231			
			$n_{2 \text{ th}}$	231	231	231	231			
19.360	70	0.06	$M_2$	11	22	28				
			c	5.1	2.6	2.0				
			$n_{2 \text{ Eck}}$	209	209	209				
			$n_{2 \text{ th}}$	209	209	209				
22.000	62	0.06	$M_2$	12	25	32				
			c	4.0	2.0	1.6				
			$n_{2 \text{ Eck}}$	184	184	184				
			$n_{2 \text{ th}}$	184	184	184				
24.933	71	0.04	$M_2$	14	29	36				
			c	4.0	2.0	1.6				
			$n_{2 \text{ Eck}}$	162	162	162				
			$n_{2 \text{ th}}$	162	162	162				
28.333	63	0.04	$M_2$	16	33	41				
			c	3.1	1.6	1.3				
			$n_{2 \text{ Eck}}$	143	143	143				
			$n_{2 \text{ th}}$	143	143	143				

$M \dots$  [Nm]  
 $n \dots$  [r/min]  
 $J \dots$  [kgcm<sup>2</sup>]

$P \dots$  [kW]  
 $I \dots$  [A]  
 $i$  [-]  
 $c$  [-]

**GST [Nm]**  
GST□□-□S (MCS)

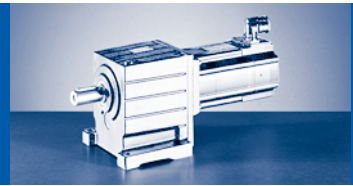

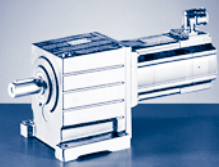

# GST [Nm]

## GST□□-□S (MCS)

$M_{2GN} \leq 54 \text{ Nm}$

GST05-1S				06CC41	06FC41	06IC41	09DC41	09FC38	09HC41	09LC41
				...500	...500	...500	...500	...500	...500	...500
i	$M_{2GN}$	$J_G$	$M_1$	0.60	1.20	1.50	2.30	3.10	3.80	4.50
			$n_1$	4050	4050	4050	4050	3750	4050	4050
			$I_{M230}$	2.6	2.9	3.2	4.6	5.0	6.8	8.4
			$I_{M400}$	1.3	1.5	1.6	2.3	2.5	3.4	4.2
			$P_N$	0.25	0.51	0.64	1.00	1.20	1.60	1.90
			$J_M$	0.17	0.25	0.33	1.13	1.53	1.93	2.83
1.600	45	0.76	$M_2$						6	7
			c					5.4	4.5	
			$n_{2 \text{ Eck}}$					2531	2531	
			$n_{2 \text{ th}}$					2236	2168	
2.048	51	0.55	$M_2$					6	7	9
			c					6.0	4.8	4.0
			$n_{2 \text{ Eck}}$					1831	1978	1978
			$n_{2 \text{ th}}$					1831	1862	1809
2.048	53	0.55	$M_2$							
			c							
			$n_{2 \text{ Eck}}$							
			$n_{2 \text{ th}}$							
2.240	53	0.48	$M_2$					7	8	10
			c					5.7	4.5	3.8
			$n_{2 \text{ Eck}}$					1674	1808	1808
			$n_{2 \text{ th}}$					1674	1748	1699
2.857	53	0.35	$M_2$				6	8	10	12
			c				5.9	4.5	3.6	3.0
			$n_{2 \text{ Eck}}$				1418	1313	1418	1418
			$n_{2 \text{ th}}$				1418	1313	1418	1418
3.500	41	0.27	$M_2$			5				
			c			5.7				
			$n_{2 \text{ Eck}}$			1157				
			$n_{2 \text{ th}}$			1157				
3.500	54	0.27	$M_2$				8	10	13	15
			c				4.9	3.7	3.0	2.5
			$n_{2 \text{ Eck}}$				1157	1071	1157	1157
			$n_{2 \text{ th}}$				1157	1071	1157	1157
4.556	42	0.18	$M_2$		5	7				
			c		5.7	4.5				
			$n_{2 \text{ Eck}}$		889	889				
			$n_{2 \text{ th}}$		889	889				
4.556	54	0.18	$M_2$				10	14	17	20
			c				3.8	2.9	2.3	1.9
			$n_{2 \text{ Eck}}$				889	823	889	889
			$n_{2 \text{ th}}$				889	823	889	889
5.667	44	0.13	$M_2$		6	8				
			c		4.7	3.8				
			$n_{2 \text{ Eck}}$		715	715				
			$n_{2 \text{ th}}$		715	715				
5.667	54	0.13	$M_2$				13	17	21	25
			c				3.0	2.3	1.8	1.5
			$n_{2 \text{ Eck}}$				715	662	715	715
			$n_{2 \text{ th}}$				715	662	715	715
7.333	46	0.06	$M_2$		8	11				
			c		3.8	3.0				
			$n_{2 \text{ Eck}}$		552	552				
			$n_{2 \text{ th}}$		552	552				
8.900	42	0.06	$M_2$	5	10	13				
			c	5.8	2.9	2.3				
			$n_{2 \text{ Eck}}$	455	455	455				
			$n_{2 \text{ th}}$	455	455	455				

$M \dots$  [Nm]  
 $n \dots$  [r/min]  
 $J \dots$  [kgcm<sup>2</sup>]

$P \dots$  [kW]  
 $I \dots$  [A]  
 $i \dots$  [-]  
 $c \dots$  [-]

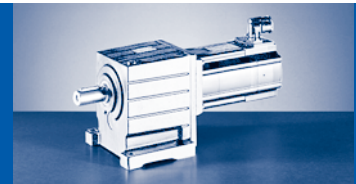

$M_{2GN} \leq 54 \text{ Nm}$

12DC20	12DC41	12HC15	12HC30	12HC35	12LC20	12LC41	GST05-1S			
...500	...500	...500	...500	...500	...500	...500				
5.50	4.30	10.00	8.00	7.50	13.50	11.00	$M_1$	$J_G$	$M_{2GN}$	$i$
1950	4050	1500	3000	3525	1950	4050	$n_1$			
5.2	8.8	7.6	10.5		11.8		$I_{M230}$			
2.6	4.5	3.8		5.7	5.9	10.2	$I_{M400}$			
1.10	1.80	1.60	2.50	2.80	2.80	4.70	$P_N$			
4.12	4.12	7.42	7.42	7.42	10.72	10.72	$J_M$			
8	7	15	12	12	21	17	$M_2$			
4.7	4.7	2.8	2.8	2.8	1.9	1.9	c	0.76	45	1.600
1219	2531	938	1875	2203	1219	2531	$n_{2\text{ Eck}}$			
1219	2186	938	1875	1982	1219	1771	$n_{2\text{ th}}$			
							$M_2$			
							c	0.55	51	2.048
							$n_{2\text{ Eck}}$			
							$n_{2\text{ th}}$			
11	8	20	16	15	27	22	$M_2$			
4.3	4.4	2.6	2.6	2.6	1.8	1.7	c	0.55	53	2.048
952	1978	733	1465	1722	952	1978	$n_{2\text{ Eck}}$			
952	1834	733	1465	1674	952	1470	$n_{2\text{ th}}$			
12	9	22	17	16	30	24	$M_2$			
4.0	4.0	2.4	2.4	2.4	1.6	1.6	c	0.48	53	2.240
871	1808	670	1339	1574	871	1808	$n_{2\text{ Eck}}$			
871	1712	670	1339	1567	871	1351	$n_{2\text{ th}}$			
15	12	28	22	21	38	31	$M_2$			
3.1	3.2	1.9	1.9	1.9	1.3	1.2	c	0.35	53	2.857
683	1418	525	1050	1234	683	1418	$n_{2\text{ Eck}}$			
683	1418	525	1050	1234	683	1120	$n_{2\text{ th}}$			
							$M_2$			
							c	0.27	41	3.500
							$n_{2\text{ Eck}}$			
							$n_{2\text{ th}}$			
19	15	34	27	26	47	38	$M_2$			
2.6	2.6	1.6	1.6	1.6	1.1	1.0	c	0.27	54	3.500
557	1157	429	857	1007	557	1157	$n_{2\text{ Eck}}$			
557	1157	429	857	1007	557	969	$n_{2\text{ th}}$			
							$M_2$			
							c	0.18	42	4.556
							$n_{2\text{ Eck}}$			
							$n_{2\text{ th}}$			
							$M_2$			
							c	0.18	54	4.556
							$n_{2\text{ Eck}}$			
							$n_{2\text{ th}}$			
							$M_2$			
							c	0.13	44	5.667
							$n_{2\text{ Eck}}$			
							$n_{2\text{ th}}$			
							$M_2$			
							c	0.13	54	5.667
							$n_{2\text{ Eck}}$			
							$n_{2\text{ th}}$			
							$M_2$			
							c	0.06	46	7.333
							$n_{2\text{ Eck}}$			
							$n_{2\text{ th}}$			
							$M_2$			
							c	0.06	42	8.900
							$n_{2\text{ Eck}}$			
							$n_{2\text{ th}}$			

M ... [Nm]  
n ... [r/min]  
J ... [kgcm<sup>2</sup>]

P ... [kW]  
I ... [A]  
i [-]  
c [-]

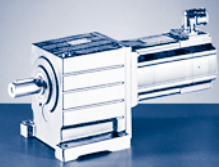

# GST [Nm]

## GST□□-□S (MCS)

$M_{2GN} \leq 165 \text{ Nm}$

GST05-2S				06CC41	06FC41	06IC41	09DC41	09FC38	09HC41	09LC41
				...500	...500	...500	...500	...500	...500	...500
i	$M_{2GN}$	$J_G$	$M_1$	0.60	1.20	1.50	2.30	3.10	3.80	4.50
			$n_1$	4050	4050	4050	4050	3750	4050	4050
			$I_{M230}$	2.6	2.9	3.2	4.6	5.0	6.8	8.4
			$I_{M400}$	1.3	1.5	1.6	2.3	2.5	3.4	4.2
			$P_N$	0.25	0.51	0.64	1.00	1.20	1.60	1.90
			$J_M$	0.17	0.25	0.33	1.13	1.53	1.93	2.83
2.956	63	0.99	$M_2$					9	11	13
			c				5.2	4.2	3.5	
			$n_{2 \text{ Eck}}$				1269	1370	1370	
			$n_{2 \text{ th}}$				1029	985	953	
3.333	78	0.94	$M_2$					10	12	14
			c				5.7	4.6	3.9	
			$n_{2 \text{ Eck}}$				1125	1215	1215	
			$n_{2 \text{ th}}$				928	889	860	
4.053	81	0.90	$M_2$					12	14	17
			c				4.9	3.9	3.3	
			$n_{2 \text{ Eck}}$				925	999	999	
			$n_{2 \text{ th}}$				869	832	806	
4.571	91	0.86	$M_2$					13	16	19
			c				4.9	3.9	3.3	
			$n_{2 \text{ Eck}}$				820	886	886	
			$n_{2 \text{ th}}$				770	738	714	
5.187	90	0.64	$M_2$			11	15	19	22	
			c			5.6	4.3	3.4	2.9	
			$n_{2 \text{ Eck}}$			781	723	781	781	
			$n_{2 \text{ th}}$			755	721	693	672	
5.850	101	0.61	$M_2$			12	17	21	25	
			c			5.6	4.2	3.4	2.9	
			$n_{2 \text{ Eck}}$			692	641	692	692	
			$n_{2 \text{ th}}$			669	639	614	596	
6.400	105	0.53	$M_2$			14	19	23	27	
			c			5.3	4.0	3.2	2.7	
			$n_{2 \text{ Eck}}$			633	586	633	633	
			$n_{2 \text{ th}}$			627	586	576	559	
7.238	108	0.40	$M_2$			16	21	26	31	
			c			4.8	3.7	2.9	2.5	
			$n_{2 \text{ Eck}}$			560	518	560	560	
			$n_{2 \text{ th}}$			560	518	560	560	
8.163	115	0.39	$M_2$			18	24	30	35	
			c			4.5	3.5	2.8	2.3	
			$n_{2 \text{ Eck}}$			496	459	496	496	
			$n_{2 \text{ th}}$			496	459	496	496	
9.010	119	0.54	$M_2$			19	26	33	39	
			c			4.2	3.2	2.6	2.2	
			$n_{2 \text{ Eck}}$			450	416	450	450	
			$n_{2 \text{ th}}$			415	396	379	367	
10.000	114	0.30	$M_2$			14				
			c			5.7				
			$n_{2 \text{ Eck}}$			405				
			$n_{2 \text{ th}}$			405				
10.000	124	0.30	$M_2$				22	29	36	43
			c				4.0	3.0	2.4	2.0
			$n_{2 \text{ Eck}}$				405	375	405	405
			$n_{2 \text{ th}}$				405	375	405	405
11.200	128	0.46	$M_2$			16	24	33	41	48
			c			5.6	3.7	2.8	2.2	1.9
			$n_{2 \text{ Eck}}$			362	362	335	362	362
			$n_{2 \text{ th}}$			362	337	322	309	294

$M \dots$  [Nm]  
 $n \dots$  [r/min]  
 $J \dots$  [kgcm<sup>2</sup>]

$P \dots$  [kW]  
 $I \dots$  [A]  
 $i \dots$  [-]  
 $c \dots$  [-]

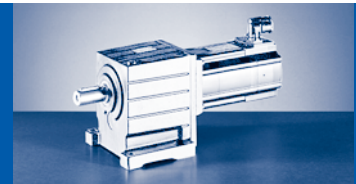

$M_{2GN} \leq 165 \text{ Nm}$

12DC20	12DC41	12HC15	12HC30	12HC35	12LC20	12LC41	GST05-2S			
...500	...500	...500	...500	...500	...500	...500				
5.50	4.30	10.00	8.00	7.50	13.50	11.00	$M_1$	$J_G$	$M_{2GN}$	$i$
1950	4050	1500	3000	3525	1950	4050	$n_1$			
5.2	8.8	7.6	10.5		11.8		$I_{M230}$			
2.6	4.5	3.8		5.7	5.9	10.2	$I_{M400}$			
1.10	1.80	1.60	2.50	2.80	2.80	4.70	$P_N$			
4.12	4.12	7.42	7.42	7.42	10.72	10.72	$J_M$			
15	12	28	23	21	39	31	$M_2$			
3.7	3.7	2.2	2.2	2.2	1.5	1.4	c	0.99	63	2.956
660	1370	508	1015	1193	660	1370	$n_{2\text{ Eck}}$			
660	961	508	861	863	660	708	$n_{2\text{ th}}$			
17	13	32	26	24	43	35	$M_2$			
4.0	4.0	2.4	2.4	2.4	1.6	1.6	c	0.94	78	3.333
585	1215	450	900	1058	585	1215	$n_{2\text{ Eck}}$			
585	868	450	779	781	585	659	$n_{2\text{ th}}$			
21	16	39	31	29	53	43	$M_2$			
3.4	3.5	2.1	2.1	2.1	1.4	1.4	c	0.90	81	4.053
481	999	370	740	870	481	999	$n_{2\text{ Eck}}$			
481	813	370	731	732	481	589	$n_{2\text{ th}}$			
24	19	44	35	33	60	49	$M_2$			
3.4	3.4	2.1	2.0	2.1	1.4	1.3	c	0.86	91	4.571
427	886	328	656	771	427	886	$n_{2\text{ Eck}}$			
427	720	328	647	649	427	521	$n_{2\text{ th}}$			
27	21	50	40	37	68	55	$M_2$			
3.0	3.0	1.8	1.8	1.8	1.2	1.2	c	0.64	90	5.187
376	781	289	578	680	376	781	$n_{2\text{ Eck}}$			
376	677	289	578	596	376	489	$n_{2\text{ th}}$			
31	24	56	45	42	76	62	$M_2$			
3.0	3.0	1.8	1.8	1.8	1.2	1.2	c	0.61	101	5.850
333	692	256	513	603	333	692	$n_{2\text{ Eck}}$			
333	601	256	513	528	333	433	$n_{2\text{ th}}$			
34	26	62	49	46	84	68	$M_2$			
2.8	2.8	1.7	1.7	1.7	1.2	1.1	c	0.53	105	6.400
305	633	234	469	551	305	633	$n_{2\text{ Eck}}$			
305	564	234	469	490	305	408	$n_{2\text{ th}}$			
38	30	70	56	52	95	77	$M_2$			
2.6	2.6	1.5	1.5	1.6	1.1	1.0	c	0.40	108	7.238
269	560	207	415	487	269	560	$n_{2\text{ Eck}}$			
269	560	207	414	487	269	407	$n_{2\text{ th}}$			
43	34	79	63	59			$M_2$			
2.4	2.4	1.5	1.4	1.5			c	0.39	115	8.163
239	496	184	368	432			$n_{2\text{ Eck}}$			
239	496	184	368	424			$n_{2\text{ th}}$			
47	37	87	70	65			$M_2$			
2.3	2.3	1.4	1.4	1.4			c	0.54	119	9.010
216	450	167	333	391			$n_{2\text{ Eck}}$			
216	371	166	300	301			$n_{2\text{ th}}$			
							$M_2$			
							c	0.30	114	10.000
							$n_{2\text{ Eck}}$			
							$n_{2\text{ th}}$			
53	41	97	77	73			$M_2$			
2.1	2.1	1.3	1.3	1.3			c	0.30	124	10.000
195	405	150	300	353			$n_{2\text{ Eck}}$			
195	405	150	300	353			$n_{2\text{ th}}$			
59	46	108	87	81			$M_2$			
2.0	2.0	1.2	1.2	1.2			c	0.46	128	11.200
174	362	134	268	315			$n_{2\text{ Eck}}$			
174	301	134	238	239			$n_{2\text{ th}}$			

M ... [Nm]  
n ... [r/min]  
J ... [kgcm<sup>2</sup>]

P ... [kW]  
I ... [A]  
i [-]  
c [-]

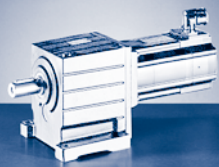

# GST [Nm]

## GST□□-□S (MCS)

$M_{2GN} \leq 165 \text{ Nm}$

GST05-2S				06CC41	06FC41	06IC41	09DC41	09FC38	09HC41	09LC41
				...500	...500	...500	...500	...500	...500	...500
i	$M_{2GN}$	$J_G$	$M_1$	0.60	1.20	1.50	2.30	3.10	3.80	4.50
			$n_1$	4050	4050	4050	4050	3750	4050	4050
			$I_{M230}$	2.6	2.9	3.2	4.6	5.0	6.8	8.4
			$I_{M400}$	1.3	1.5	1.6	2.3	2.5	3.4	4.2
			$P_N$	0.25	0.51	0.64	1.00	1.20	1.60	1.90
			$J_M$	0.17	0.25	0.33	1.13	1.53	1.93	2.83
13.016	119	0.18	$M_2$		14	18				
			c		5.7	4.5				
			$n_{2 \text{ Eck}}$		311	311				
			$n_{2 \text{ th}}$		311	311				
13.016	137	0.18	$M_2$				28	39	47	56
			c				3.4	2.6	2.1	1.7
			$n_{2 \text{ Eck}}$				311	288	311	311
			$n_{2 \text{ th}}$				311	288	311	311
14.356	110	0.13	$M_2$		16	20				
			c		4.7	3.8				
			$n_{2 \text{ Eck}}$		282	282				
			$n_{2 \text{ th}}$		282	282				
14.356	140	0.13	$M_2$				31	43	52	62
			c				3.1	2.4	1.9	1.6
			$n_{2 \text{ Eck}}$				282	261	282	282
			$n_{2 \text{ th}}$				282	261	282	282
16.190	124	0.13	$M_2$		18	23				
			c		5.4	4.3				
			$n_{2 \text{ Eck}}$		250	250				
			$n_{2 \text{ th}}$		250	250				
16.190	148	0.13	$M_2$				35	48	59	70
			c				3.4	2.6	2.0	1.7
			$n_{2 \text{ Eck}}$				250	232	250	250
			$n_{2 \text{ th}}$				250	232	250	250
17.500	142	0.27	$M_2$		19	25	38	52	64	76
			c		5.7	4.6	3.0	2.3	1.8	1.5
			$n_{2 \text{ Eck}}$		231	231	231	214	231	231
			$n_{2 \text{ th}}$		231	231	231	214	231	226
20.044	159	0.16	$M_2$		22	28	44	60	73	87
			c		5.6	4.5	2.9	2.2	1.8	1.5
			$n_{2 \text{ Eck}}$		202	202	202	187	202	202
			$n_{2 \text{ th}}$		202	202	202	187	202	202
22.778	144	0.16	$M_2$		26	32	50	68	84	99
			c		4.4	3.5	2.3	1.8	1.4	1.2
			$n_{2 \text{ Eck}}$		178	178	178	165	178	178
			$n_{2 \text{ th}}$		178	178	178	165	178	178
24.933	162	0.12	$M_2$		28	35	55	74	92	109
			c		4.6	3.6	2.4	1.8	1.4	1.2
			$n_{2 \text{ Eck}}$		162	162	162	150	162	162
			$n_{2 \text{ th}}$		162	162	162	150	162	162
28.333	147	0.12	$M_2$		32	40	63	85	104	
			c		3.6	2.9	1.9	1.4	1.2	
			$n_{2 \text{ Eck}}$		143	143	143	132	143	
			$n_{2 \text{ th}}$		143	143	143	132	143	
32.267	164	0.08	$M_2$		37	46				
			c		3.6	2.9				
			$n_{2 \text{ Eck}}$		126	126				
			$n_{2 \text{ th}}$		126	126				
36.667	148	0.08	$M_2$	20	42	53				
			c	5.7	2.8	2.3				
			$n_{2 \text{ Eck}}$	111	111	111				
			$n_{2 \text{ th}}$	110	110	110				

$M \dots$  [Nm]  
 $n \dots$  [r/min]  
 $J \dots$  [kgcm<sup>2</sup>]

$P \dots$  [kW]  
 $I \dots$  [A]  
 $i$  [-]  
 $c$  [-]

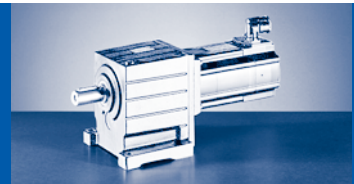

$M_{2GN} \leq 165 \text{ Nm}$

12DC20	12DC41	12HC15	12HC30	12HC35	12LC20	12LC41	GST05-2S			
...500	...500	...500	...500	...500	...500	...500	$M_1$	$J_G$	$M_{2GN}$	i
5.50	4.30	10.00	8.00	7.50	13.50	11.00	$n_1$			
1950	4050	1500	3000	3525	1950	4050	$I_{M230}$			
5.2	8.8	7.6	10.5		11.8		$I_{M400}$			
2.6	4.5	3.8		5.7	5.9	10.2	$P_N$			
1.10	1.80	1.60	2.50	2.80	2.80	4.70	$J_M$			
4.12	4.12	7.42	7.42	7.42	10.72	10.72	$M_2$ c			
							$n_2$ Eck	0.18	119	13.016
							$n_2$ th			
							$M_2$ c			
							$n_2$ Eck	0.18	137	13.016
							$n_2$ th			
							$M_2$ c			
							$n_2$ Eck	0.13	110	14.356
							$n_2$ th			
							$M_2$ c			
							$n_2$ Eck	0.13	140	14.356
							$n_2$ th			
							$M_2$ c			
							$n_2$ Eck	0.13	124	16.190
							$n_2$ th			
							$M_2$ c			
							$n_2$ Eck	0.13	148	16.190
							$n_2$ th			
93	73						$M_2$ c			
1.5	1.6						$n_2$ Eck	0.27	142	17.500
111	231						$n_2$ th			
111	231						$M_2$ c			
							$n_2$ Eck	0.16	159	20.044
							$n_2$ th			
							$M_2$ c			
							$n_2$ Eck	0.16	144	22.778
							$n_2$ th			
							$M_2$ c			
							$n_2$ Eck	0.12	162	24.933
							$n_2$ th			
							$M_2$ c			
							$n_2$ Eck	0.12	147	28.333
							$n_2$ th			
							$M_2$ c			
							$n_2$ Eck	0.08	164	32.267
							$n_2$ th			
							$M_2$ c			
							$n_2$ Eck	0.08	148	36.667
							$n_2$ th			

M ... [Nm]  
n ... [r/min]  
J ... [kgcm<sup>2</sup>]

P ... [kW]  
I ... [A]  
i [-]  
c [-]

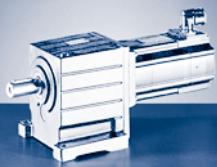

# GST [Nm]

## GST□□-□S (MCS)

$M_{2GN} \leq 165 \text{ Nm}$

GST05-2S				06CC41	06FC41	06IC41	09DC41	09FC38	09HC41	09LC41
				...500	...500	...500	...500	...500	...500	...500
i	$M_{2GN}$	$J_G$	$M_1$	0.60	1.20	1.50	2.30	3.10	3.80	4.50
			$n_1$	4050	4050	4050	4050	3750	4050	4050
			$I_{M230}$	2.6	2.9	3.2	4.6	5.0	6.8	8.4
			$I_{M400}$	1.3	1.5	1.6	2.3	2.5	3.4	4.2
			$P_N$	0.25	0.51	0.64	1.00	1.20	1.60	1.90
			$J_M$	0.17	0.25	0.33	1.13	1.53	1.93	2.83
39.160	165	0.06	$M_2$	22	45	56				
			c	5.9	3.0	2.4				
			$n_{2 \text{ Eck}}$	103	103	103				
			$n_{2 \text{ th}}$	103	103	103				
44.500	149	0.06	$M_2$	25	51	64				
			c	5.2	2.6	2.1				
			$n_{2 \text{ Eck}}$	91	91	91				
			$n_{2 \text{ th}}$	91	91	91				

M ... [Nm]  
 n ... [r/min]  
 J ... [kgcm<sup>2</sup>]

P ... [kW]  
 I ... [A]  
 i [-]  
 c [-]

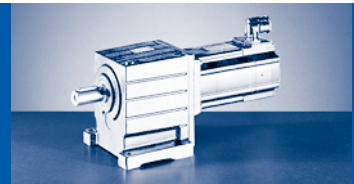

$M_{2GN} \leq 165 \text{ Nm}$

12DC20	12DC41	12HC15	12HC30	12HC35	12LC20	12LC41	GST05-2S			
...500	...500	...500	...500	...500	...500	...500	$M_1$	$J_G$	$M_{2GN}$	$i$
5.50	4.30	10.00	8.00	7.50	13.50	11.00	$n_1$			
1950	4050	1500	3000	3525	1950	4050	$I_{M230}$			
5.2	8.8	7.6	10.5		11.8		$I_{M400}$			
2.6	4.5	3.8		5.7	5.9	10.2	$P_N$			
1.10	1.80	1.60	2.50	2.80	2.80	4.70	$J_M$			
4.12	4.12	7.42	7.42	7.42	10.72	10.72	$M_2$ c $n_2$ Eck $n_2$ th	0.06	165	39.160
							$M_2$ c $n_2$ Eck $n_2$ th	0.06	149	44.500

M ... [Nm]  
n ... [r/min]  
J ... [kgcm<sup>2</sup>]

P ... [kW]  
I ... [A]  
i [-]  
c [-]

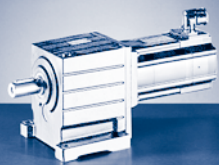

# GST [Nm]

## GST□□-□S (MCS)

$M_{2GN} \leq 171 \text{ Nm}$

GST05-3S				06CC41	06FC41	06IC41	09DC41	09FC38
				...500	...500	...500	...500	...500
i	$M_{2GN}$	$J_G$	$M_1$					
			$n_1$	4050	4050	4050	4050	3750
			$I_{M230}$	2.6	2.9	3.2	4.6	5.0
			$I_{M400}$	1.3	1.5	1.6	2.3	2.5
			$P_N$	0.25	0.51	0.64	1.00	1.20
			$J_M$	0.17	0.25	0.33	1.13	1.53
36.267	134	0.20	$M_2$	20	41	51	79	107
			c	5.3	2.6	2.1	1.4	1.1
			$n_{2 \text{ Eck}}$	112	112	112	112	103
			$n_{2 \text{ th}}$	112	112	112	112	103
46.259	145	0.14	$M_2$	25	52	66	101	
			c	5.0	2.5	2.0	1.3	
			$n_{2 \text{ Eck}}$	88	88	88	88	
			$n_{2 \text{ th}}$	88	88	88	88	
56.667	155	0.11	$M_2$	31	64	81	124	
			c	4.3	2.2	1.7	1.1	
			$n_{2 \text{ Eck}}$	72	72	72	72	
			$n_{2 \text{ th}}$	71	71	71	71	
63.467	146	0.19	$M_2$	35	72	91		
			c	3.6	1.8	1.5		
			$n_{2 \text{ Eck}}$	64	64	64		
			$n_{2 \text{ th}}$	64	64	64		
71.238	167	0.07	$M_2$	40	81	102		
			c	3.7	1.9	1.5		
			$n_{2 \text{ Eck}}$	57	57	57		
			$n_{2 \text{ th}}$	57	57	57		
80.952	147	0.14	$M_2$	46	92	116		
			c	2.9	1.4	1.2		
			$n_{2 \text{ Eck}}$	50	50	50		
			$n_{2 \text{ th}}$	50	50	50		
91.746	171	0.05	$M_2$	52	105	131		
			c	2.9	1.5	1.2		
			$n_{2 \text{ Eck}}$	44	44	44		
			$n_{2 \text{ th}}$	44	44	44		
99.167	148	0.11	$M_2$	56	114			
			c	2.4	1.2			
			$n_{2 \text{ Eck}}$	41	41			
			$n_{2 \text{ th}}$	41	41			
124.667	149	0.07	$M_2$	71				
			c	1.9				
			$n_{2 \text{ Eck}}$	33				
			$n_{2 \text{ th}}$	32				
160.556	150	0.05	$M_2$	92				
			c	1.5				
			$n_{2 \text{ Eck}}$	25				
			$n_{2 \text{ th}}$	25				

M ... [Nm]  
 n ... [r/min]  
 J ... [kgcm<sup>2</sup>]

P ... [kW]  
 I ... [A]  
 i [-]  
 c [-]

**GST [Nm]**  
GST□□-□S (MCS)

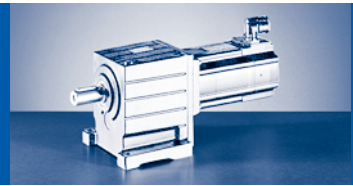

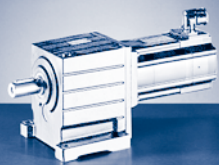

# GST [Nm]

## GST□□-□S (MCS)

$M_{2GN} \leq 105 \text{ Nm}$

GST06-1S				06FC41	06IC41	09DC41	09FC38	09HC41	09LC41	12DC20	12DC41	12HC15	12HC30	
				...500	...500	...500	...500	...500	...500	...500	...500	...500	...500	
i	$M_{2GN}$	$J_G$	$M_1$	1.20	1.50	2.30	3.10	3.80	4.50	5.50	4.30	10.00	8.00	
			$n_1$	4050	4050	4050	3750	4050	4050	1950	4050	1500	3000	
			$I_{M230}$	2.9	3.2	4.6	5.0	6.8	8.4	5.2	8.8	7.6	10.5	
			$I_{M400}$	1.5	1.6	2.3	2.5	3.4	4.2	2.6	4.5	3.8		
			$P_N$	0.51	0.64	1.00	1.20	1.60	1.90	1.10	1.80	1.60	2.50	
			$J_M$	0.25	0.33	1.13	1.53	1.93	2.83	4.12	4.12	7.42	7.42	
1.600	61	2.01	$M_2$									15	12	
			c										3.9	3.9
			$n_{2 \text{ Eck}}$										938	1875
			$n_{2 \text{ th}}$										938	1759
2.048	63	1.46	$M_2$					7	9					
			c					5.9	5.0					
			$n_{2 \text{ Eck}}$					1978	1978					
			$n_{2 \text{ th}}$					1725	1672					
2.048	72	1.46	$M_2$							11	8	20	16	
			c							6.0	6.0	3.6	3.6	
			$n_{2 \text{ Eck}}$							952	1978	733	1465	
			$n_{2 \text{ th}}$							952	1730	733	1465	
2.240	66	1.27	$M_2$					8	10					
			c					5.6	4.8					
			$n_{2 \text{ Eck}}$					1808	1808					
			$n_{2 \text{ th}}$					1612	1564					
2.240	79	1.27	$M_2$							12	9	21	17	
			c							5.9	5.9	3.6	3.5	
			$n_{2 \text{ Eck}}$							871	1808	670	1339	
			$n_{2 \text{ th}}$							871	1627	670	1339	
2.857	71	0.97	$M_2$				8	10	12					
			c				6.0	4.8	4.0					
			$n_{2 \text{ Eck}}$				1313	1418	1418					
			$n_{2 \text{ th}}$				1313	1346	1309					
2.857	91	0.97	$M_2$							15	12	28	22	
			c							5.4	5.4	3.3	3.2	
			$n_{2 \text{ Eck}}$							683	1418	525	1050	
			$n_{2 \text{ th}}$							683	1376	525	1050	
2.857	92	0.97	$M_2$											
			c											
			$n_{2 \text{ Eck}}$											
			$n_{2 \text{ th}}$											
3.500	74	0.74	$M_2$				10	13	15					
			c				5.1	4.1	3.4					
			$n_{2 \text{ Eck}}$				1071	1157	1157					
			$n_{2 \text{ th}}$				1071	1157	1157					
3.500	96	0.74	$M_2$							18	14	34	27	
			c							4.6	4.7	2.8	2.8	
			$n_{2 \text{ Eck}}$							557	1157	429	857	
			$n_{2 \text{ th}}$							557	1157	429	857	
3.500	105	0.74	$M_2$											
			c											
			$n_{2 \text{ Eck}}$											
			$n_{2 \text{ th}}$											
4.556	52	0.48	$M_2$		6									
			c		5.6									
			$n_{2 \text{ Eck}}$		889									
			$n_{2 \text{ th}}$		889									
4.556	78	0.48	$M_2$			10	13	17	20					
			c			5.4	4.1	3.3	2.8					
			$n_{2 \text{ Eck}}$			889	823	889	889					
			$n_{2 \text{ th}}$			889	823	889	889					

$M \dots$  [Nm]  
 $n \dots$  [r/min]  
 $J \dots$  [kgcm<sup>2</sup>]

$P \dots$  [kW]  
 $I \dots$  [A]  
 $i \dots$  [-]  
 $c \dots$  [-]

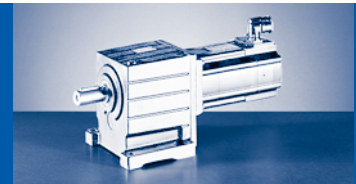

$M_{2GN} \leq 105 \text{ Nm}$

12HC35	12LC20	12LC41	14DC15	14DC36	14HC15	14HC32	14LC15	14LC32	14PC14	14PC32	GST06-1S			
...500	...500	...500	...500	...500	...500	...500	...500	...500	...500	...500				
7.50	13.50	11.00	9.20	7.50	16.00	14.00	23.00	17.20	30.00	21.00	$M_1$	$J_G$	$M_{2GN}$	$i$
3525	1950	4050	1500	3600	1500	3225	1500	3225	1350	3225	$n_1$			
	11.8										$I_{M230}$			
5.7	5.9	10.2	4.5	7.5	6.6	11.9	9.7	15.0	10.8	15.6	$I_{M400}$			
2.80	2.80	4.70	1.45	2.80	2.50	4.70	3.60	5.80	4.20	7.10	$P_N$			
7.42	10.72	10.72	8.22	8.22	14.32	14.32	23.44	23.44	34.74	34.82	$J_M$			
11	21	17	14	11	25	22	36	27	47	33	$M_2$			
3.9	2.6	2.5	4.2	3.9	2.4	2.2	1.7	1.8	1.3	1.4	c	2.01	61	1.600
2203	1219	2531	938	2250	938	2016	938	2016	844	2016	$n_2$ Eck			
1763	1219	1610	938	1760	938	1551	938	1421	844	1274	$n_2$ th			
											$M_2$			
											c	1.46	63	2.048
											$n_2$ Eck			
											$n_2$ th			
15	27	22	18	15	32	28	46	34	60	42	$M_2$			
3.6	2.4	2.3	3.9	3.6	2.2	2.0	1.6	1.6	1.2	1.3	c	1.46	72	2.048
1722	952	1978	733	1758	733	1575	733	1575	659	1575	$n_2$ Eck			
1570	952	1436	733	1568	733	1390	733	1230	659	1103	$n_2$ th			
											$M_2$			
											c	1.27	66	2.240
											$n_2$ Eck			
											$n_2$ th			
16	29	24	20	16	35	31	50	38	66	46	$M_2$			
3.6	2.4	2.3	3.9	3.5	2.2	2.0	1.6	1.6	1.2	1.3	c	1.27	79	2.240
1574	871	1808	670	1607	670	1440	670	1440	603	1440	$n_2$ Eck			
1482	871	1359	670	1480	670	1313	670	1167	603	1053	$n_2$ th			
											$M_2$			
											c	0.97	71	2.857
											$n_2$ Eck			
											$n_2$ th			
21	38	31									$M_2$			
3.3	2.2	2.1									c	0.97	91	2.857
1234	683	1418									$n_2$ Eck			
1234	683	1166									$n_2$ th			
			25	21	45	39	64	48	84	59	$M_2$			
			3.6	3.3	2.1	1.8	1.4	1.5	1.1	1.2	c	0.97	92	2.857
			525	1260	525	1129	525	1129	473	1129	$n_2$ Eck			
			525	1257	525	1103	525	998	473	914	$n_2$ th			
											$M_2$			
											c	0.74	74	3.500
											$n_2$ Eck			
											$n_2$ th			
25	46	38									$M_2$			
2.8	1.9	1.8									c	0.74	96	3.500
1007	557	1157									$n_2$ Eck			
1007	557	1060									$n_2$ th			
			31	25	55	48	79	59	103	72	$M_2$			
			3.3	3.0	1.9	1.7	1.3	1.4	1.0	1.1	c	0.74	105	3.500
			429	1029	429	921	429	921	386	921	$n_2$ Eck			
			429	1026	429	921	429	913	386	833	$n_2$ th			
											$M_2$			
											c	0.48	52	4.556
											$n_2$ Eck			
											$n_2$ th			
											$M_2$			
											c	0.48	78	4.556
											$n_2$ Eck			
											$n_2$ th			

M ... [Nm]  
n ... [r/min]  
J ... [kgcm<sup>2</sup>]

P ... [kW]  
I ... [A]  
i [-]  
c [-]

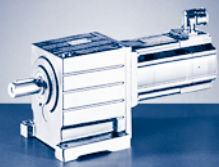

# GST [Nm]

## GST□□-□S (MCS)

$M_{2GN} \leq 105 \text{ Nm}$

GST06-1S				06FC41	06IC41	09DC41	09FC38	09HC41	09LC41	12DC20	12DC41	12HC15	12HC30
				...500	...500	...500	...500	...500	...500	...500	...500	...500	...500
i	$M_{2GN}$	$J_G$	$M_1$	1.20	1.50	2.30	3.10	3.80	4.50	5.50	4.30	10.00	8.00
			$n_1$	4050	4050	4050	3750	4050	4050	1950	4050	1500	3000
			$I_{M230}$	2.9	3.2	4.6	5.0	6.8	8.4	5.2	8.8	7.6	10.5
			$I_{M400}$	1.5	1.6	2.3	2.5	3.4	4.2	2.6	4.5	3.8	
			$P_N$	0.51	0.64	1.00	1.20	1.60	1.90	1.10	1.80	1.60	2.50
			$J_M$	0.25	0.33	1.13	1.53	1.93	2.83	4.12	4.12	7.42	7.42
4.556	100	0.48	$M_2$							24	19	44	35
			c							3.7	3.7	2.2	2.2
			$n_{2 \text{ Eck}}$							428	889	329	659
			$n_{2 \text{ th}}$							428	889	329	659
5.667	54	0.36	$M_2$	6	8								
			c	5.8	4.7								
			$n_{2 \text{ Eck}}$	715	715								
			$n_{2 \text{ th}}$	715	715								
5.667	81	0.36	$M_2$			12	17	21	25				
			c			4.5	3.4	2.7	2.3				
			$n_{2 \text{ Eck}}$			715	662	715	715				
			$n_{2 \text{ th}}$			715	662	715	715				
5.667	104	0.36	$M_2$							30	23	55	44
			c							3.1	3.1	1.9	1.9
			$n_{2 \text{ Eck}}$							344	715	265	529
			$n_{2 \text{ th}}$							344	715	265	529
7.333	56	0.23	$M_2$	8	11								
			c	4.7	3.7								
			$n_{2 \text{ Eck}}$	552	552								
			$n_{2 \text{ th}}$	552	552								
7.333	83	0.23	$M_2$			16	22	27	32				
			c			3.6	2.8	2.2	1.8				
			$n_{2 \text{ Eck}}$			552	511	552	552				
			$n_{2 \text{ th}}$			552	511	552	552				
8.900	57	0.17	$M_2$	10	13								
			c	3.9	3.1								
			$n_{2 \text{ Eck}}$	455	455								
			$n_{2 \text{ th}}$	455	455								
8.900	84	0.17	$M_2$			20	27	33	39				
			c			3.0	2.3	1.8	1.5				
			$n_{2 \text{ Eck}}$			455	421	455	455				
			$n_{2 \text{ th}}$			455	421	455	455				
11.250	56	0.11	$M_2$	13	16								
			c	3.1	2.4								
			$n_{2 \text{ Eck}}$	360	360								
			$n_{2 \text{ th}}$	360	360								

$M \dots$  [Nm]  
 $n \dots$  [r/min]  
 $J \dots$  [kgcm<sup>2</sup>]

$P \dots$  [kW]  
 $I \dots$  [A]  
 $i \dots$  [-]  
 $c \dots$  [-]

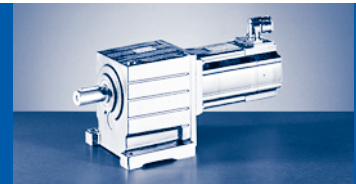

$M_{2GN} \leq 105 \text{ Nm}$

12HC35	12LC20	12LC41	14DC15	14DC36	14HC15	14HC32	14LC15	14LC32	14PC14	14PC32	GST06-1S			
...500	...500	...500	...500	...500	...500	...500	...500	...500	...500	...500	$M_1$	$J_G$	$M_{2GN}$	i
7.50	13.50	11.00	9.20	7.50	16.00	14.00	23.00	17.20	30.00	21.00	$n_1$			
3525	1950	4050	1500	3600	1500	3225	1500	3225	1350	3225	$I_{M230}$			
	11.8										$I_{M400}$			
5.7	5.9	10.2	4.5	7.5	6.6	11.9	9.7	15.0	10.8	15.6	$P_N$			
2.80	2.80	4.70	1.45	2.80	2.50	4.70	3.60	5.80	4.20	7.10	$J_M$			
7.42	10.72	10.72	8.22	8.22	14.32	14.32	23.44	23.44	34.74	34.82	$M_2$			
33	60	49									c	0.48	100	4.556
2.2	1.5	1.5									$n_2$ Eck			
774	428	889									$n_2$ th			
774	428	848									$M_2$			
											c	0.36	54	5.667
											$n_2$ Eck			
											$n_2$ th			
											$M_2$			
											c	0.36	81	5.667
											$n_2$ Eck			
											$n_2$ th			
41	75	61									$M_2$			
1.9	1.3	1.2									c	0.36	104	5.667
622	344	715									$n_2$ Eck			
622	344	715									$n_2$ th			
											$M_2$			
											c	0.23	56	7.333
											$n_2$ Eck			
											$n_2$ th			
											$M_2$			
											c	0.23	83	7.333
											$n_2$ Eck			
											$n_2$ th			
											$M_2$			
											c	0.17	57	8.900
											$n_2$ Eck			
											$n_2$ th			
											$M_2$			
											c	0.17	84	8.900
											$n_2$ Eck			
											$n_2$ th			
											$M_2$			
											c	0.11	56	11.250
											$n_2$ Eck			

M ... [Nm]  
n ... [r/min]  
J ... [kgcm<sup>2</sup>]

P ... [kW]  
I ... [A]  
i [-]  
c [-]

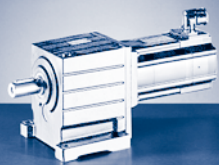

# GST [Nm]

## GST□□-□S (MCS)

$M_{2GN} \leq 366 \text{ Nm}$

GST06-2S				06FC41	06IC41	09DC41	09FC38	09HC41	09LC41	12DC20	12DC41	12HC15	12HC30	
				...500	...500	...500	...500	...500	...500	...500	...500	...500	...500	
i	$M_{2GN}$	$J_G$	$M_1$	1.20	1.50	2.30	3.10	3.80	4.50	5.50	4.30	10.00	8.00	
			$n_1$	4050	4050	4050	3750	4050	4050	1950	4050	1500	3000	
			$I_{M230}$	2.9	3.2	4.6	5.0	6.8	8.4	5.2	8.8	7.6	10.5	
			$I_{M400}$	1.5	1.6	2.3	2.5	3.4	4.2	2.6	4.5	3.8		
			$P_N$	0.51	0.64	1.00	1.20	1.60	1.90	1.10	1.80	1.60	2.50	
			$J_M$	0.25	0.33	1.13	1.53	1.93	2.83	4.12	4.12	7.42	7.42	
3.033	166	2.72	$M_2$									28	22	
			c									5.7	5.6	
			$n_{2 \text{ Eck}}$										495	989
			$n_{2 \text{ th}}$										495	862
3.333	174	2.61	$M_2$									31	25	
			c									5.4	5.3	
			$n_{2 \text{ Eck}}$										450	900
			$n_{2 \text{ th}}$										450	777
4.160	191	2.51	$M_2$									39	31	
			c									4.7	4.7	
			$n_{2 \text{ Eck}}$										361	721
			$n_{2 \text{ th}}$										361	703
4.571	200	2.41	$M_2$									43	34	
			c									4.5	4.5	
			$n_{2 \text{ Eck}}$										328	656
			$n_{2 \text{ th}}$										328	634
5.324	161	1.76	$M_2$					19	22					
			c					5.9	5.0					
			$n_{2 \text{ Eck}}$					761	761					
			$n_{2 \text{ th}}$					663	643					
5.324	207	1.76	$M_2$									50	40	
			c									4.0	4.0	
			$n_{2 \text{ Eck}}$										282	564
			$n_{2 \text{ th}}$										282	564
5.850	177	1.71	$M_2$					20	24					
			c					5.9	5.0					
			$n_{2 \text{ Eck}}$					692	692					
			$n_{2 \text{ th}}$					604	585					
5.850	222	1.71	$M_2$									55	44	
			c									3.9	3.9	
			$n_{2 \text{ Eck}}$										256	513
			$n_{2 \text{ th}}$										256	513
6.400	185	1.47	$M_2$					22	27					
			c					5.6	4.8					
			$n_{2 \text{ Eck}}$					633	633					
			$n_{2 \text{ th}}$					564	547					
6.400	229	1.47	$M_2$									60	48	
			c									3.7	3.7	
			$n_{2 \text{ Eck}}$										234	469
			$n_{2 \text{ th}}$										234	469
7.040	236	2.07	$M_2$							36	28	67	53	
			c							5.8	5.8	3.5	3.4	
			$n_{2 \text{ Eck}}$							277	575	213	426	
			$n_{2 \text{ th}}$							277	432	213	390	
8.163	199	1.06	$M_2$				23	29	35					
			c				6.0	4.8	4.0					
			$n_{2 \text{ Eck}}$				459	496	496					
			$n_{2 \text{ th}}$				459	471	458					
8.163	252	1.06	$M_2$							42	33	77	62	
			c							5.3	5.3	3.2	3.2	
			$n_{2 \text{ Eck}}$							239	496	184	368	
			$n_{2 \text{ th}}$							239	480	184	368	

$M \dots$  [Nm]  
 $n \dots$  [r/min]  
 $J \dots$  [kgcm<sup>2</sup>]

$P \dots$  [kW]  
 $I \dots$  [A]  
 $i \dots$  [-]  
 $c \dots$  [-]

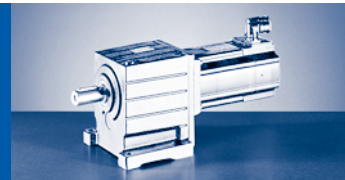

$M_{2GN} \leq 366 \text{ Nm}$

12HC35	12LC20	12LC41	14DC15	14DC36	14HC15	14HC32	14LC15	14LC32	14PC14	14PC32	GST06-2S			
...500	...500	...500	...500	...500	...500	...500	...500	...500	...500	...500				
7.50	13.50	11.00	9.20	7.50	16.00	14.00	23.00	17.20	30.00	21.00	$M_1$	$J_G$	$M_{2GN}$	$i$
3525	1950	4050	1500	3600	1500	3225	1500	3225	1350	3225	$n_1$			
	11.8										$I_{M230}$			
5.7	5.9	10.2	4.5	7.5	6.6	11.9	9.7	15.0	10.8	15.6	$I_{M400}$			
2.80	2.80	4.70	1.45	2.80	2.50	4.70	3.60	5.80	4.20	7.10	$P_N$			
7.42	10.72	10.72	8.22	8.22	14.32	14.32	23.44	23.44	34.74	34.82	$J_M$			
21	39	31		21	46	40	67	50	87	61	$M_2$			
5.7	3.8	3.7		5.6	3.5	3.1	2.5	2.6	1.9	2.1	c	2.72	166	3.033
1162	643	1335		1187	495	1063	495	1063	445	1063	$n_2 \text{ Eck}$			
864	643	791		862	495	764	495	729	445	696	$n_2 \text{ th}$			
23	42	35	28	23	50	44	73	55	96	67	$M_2$			
5.4	3.7	3.5	5.9	5.4	3.4	3.0	2.3	2.4	1.8	2.0	c	2.61	174	3.333
1058	585	1215	450	1080	450	968	450	968	405	968	$n_2 \text{ Eck}$			
778	585	713	450	777	450	687	450	656	405	628	$n_2 \text{ th}$			
29	53	43	36	29	63	56	92	69	120	84	$M_2$			
4.8	3.2	3.1	5.2	4.7	3.0	2.6	2.1	2.1	1.6	1.8	c	2.51	191	4.160
847	469	974	361	865	361	775	361	775	325	775	$n_2 \text{ Eck}$			
705	469	646	361	704	361	623	361	595	325	545	$n_2 \text{ th}$			
32	59	48	39	32	70	61	101	75	132	93	$M_2$			
4.5	3.1	2.9	4.9	4.5	2.8	2.5	2.0	2.0	1.5	1.7	c	2.41	200	4.571
771	427	886	328	788	328	706	328	706	295	706	$n_2 \text{ Eck}$			
635	427	582	328	634	328	561	328	535	295	482	$n_2 \text{ th}$			
											$M_2$			
											c	1.76	161	5.324
											$n_2 \text{ Eck}$			
											$n_2 \text{ th}$			
38	68	56	46	38	81	71	118	88	154	108	$M_2$			
4.0	2.7	2.6	4.4	4.0	2.5	2.2	1.8	1.8	1.3	1.5	c	1.76	207	5.324
662	366	761	282	676	282	606	282	606	254	606	$n_2 \text{ Eck}$			
617	366	566	282	617	282	546	282	505	254	450	$n_2 \text{ th}$			
											$M_2$			
											c	1.71	177	5.850
											$n_2 \text{ Eck}$			
											$n_2 \text{ th}$			
41	75	61	50	41	89	79	130	97	170	119	$M_2$			
3.9	2.7	2.6	4.3	3.9	2.4	2.2	1.7	1.8	1.3	1.4	c	1.71	222	5.850
603	333	692	256	615	256	551	256	551	231	551	$n_2 \text{ Eck}$			
559	333	512	256	558	256	494	256	452	231	404	$n_2 \text{ th}$			
											$M_2$			
											c	1.47	185	6.400
											$n_2 \text{ Eck}$			
											$n_2 \text{ th}$			
45	83	67	55	45	98	86	142	106	186	130	$M_2$			
3.7	2.5	2.4	4.0	3.7	2.3	2.0	1.6	1.7	1.2	1.4	c	1.47	229	6.400
551	305	633	234	563	234	504	234	504	211	504	$n_2 \text{ Eck}$			
522	305	479	234	522	234	463	234	417	211	375	$n_2 \text{ th}$			
50	91	74	61	50	108	95	156	117	205	143	$M_2$			
3.5	2.4	2.3	3.8	3.4	2.2	1.9	1.5	1.6	1.2	1.3	c	2.07	236	7.040
501	277	575	213	511	213	458	213	458	192	458	$n_2 \text{ Eck}$			
391	277	356	213	390	213	340	213	302	192	273	$n_2 \text{ th}$			
											$M_2$			
											c	1.06	199	8.163
											$n_2 \text{ Eck}$			
											$n_2 \text{ th}$			
58	106	86	71	58	125	110	181	136	237	166	$M_2$			
3.2	2.2	2.1	3.5	3.2	2.0	1.8	1.4	1.4	1.1	1.2	c	1.06	252	8.163
432	239	496	184	441	184	395	184	395	165	395	$n_2 \text{ Eck}$			
432	239	406	184	439	184	380	184	344	165	316	$n_2 \text{ th}$			

M ... [Nm]  
n ... [r/min]  
J ... [kgcm<sup>2</sup>]

P ... [kW]  
I ... [A]  
i [-]  
c [-]

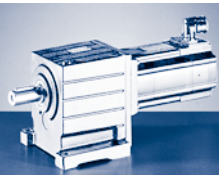

# GST [Nm]

## GST□□-□S (MCS)

$M_{2GN} \leq 366 \text{ Nm}$

GST06-2S				06FC41	06IC41	09DC41	09FC38	09HC41	09LC41	12DC20	12DC41	12HC15	12HC30
				...500	...500	...500	...500	...500	...500	...500	...500	...500	...500
i	$M_{2GN}$	$J_G$	$M_1$	1.20	1.50	2.30	3.10	3.80	4.50	5.50	4.30	10.00	8.00
			$n_1$	4050	4050	4050	3750	4050	4050	1950	4050	1500	3000
			$I_{M230}$	2.9	3.2	4.6	5.0	6.8	8.4	5.2	8.8	7.6	10.5
			$I_{M400}$	1.5	1.6	2.3	2.5	3.4	4.2	2.6	4.5	3.8	
			$P_N$	0.51	0.64	1.00	1.20	1.60	1.90	1.10	1.80	1.60	2.50
			$J_M$	0.25	0.33	1.13	1.53	1.93	2.83	4.12	4.12	7.42	7.42
9.010	261	1.50	$M_2$					32	38	46	36	86	69
			c				5.6	4.8	5.0	5.0	3.0	3.0	
			$n_{2 \text{ Eck}}$				450	450	216	450	167	333	
			$n_{2 \text{ th}}$				389	377	216	380	166	333	
10.000	209	0.82	$M_2$				29	36	43				
			c				5.1	4.1	3.4				
			$n_{2 \text{ Eck}}$				375	405	405				
			$n_{2 \text{ th}}$				375	405	405				
10.000	269	0.82	$M_2$							51	40	95	76
			c							4.6	4.6	2.8	2.8
			$n_{2 \text{ Eck}}$							195	405	150	300
			$n_{2 \text{ th}}$							195	405	150	300
11.200	280	1.26	$M_2$					40	47	58	45	107	86
			c					4.9	4.1	4.3	4.3	2.6	2.6
			$n_{2 \text{ Eck}}$					362	362	174	362	134	268
			$n_{2 \text{ th}}$					314	304	174	307	134	268
12.571	295	0.96	$M_2$				36	45	53	65	51	120	96
			c				5.8	4.6	3.9	4.0	4.0	2.4	2.4
			$n_{2 \text{ Eck}}$				298	322	322	155	322	119	239
			$n_{2 \text{ th}}$				298	304	295	155	298	119	239
14.286	307	0.93	$M_2$				41	51	61	74	58	137	110
			c				5.3	4.2	3.5	3.7	3.7	2.2	2.2
			$n_{2 \text{ Eck}}$				263	284	284	137	284	105	210
			$n_{2 \text{ th}}$				263	264	256	137	258	105	210
15.400	318	0.75	$M_2$				44	55	65	80	62	148	118
			c				5.8	4.6	3.9	3.9	4.0	2.1	2.4
			$n_{2 \text{ Eck}}$				244	263	263	127	263	97	195
			$n_{2 \text{ th}}$				244	263	263	127	263	97	195
17.500	313	0.73	$M_2$				50	63	75	91	71	168	134
			c				5.0	4.0	3.3	3.4	3.5	1.8	2.1
			$n_{2 \text{ Eck}}$				214	231	231	111	231	86	171
			$n_{2 \text{ th}}$				214	231	231	111	231	86	171
20.044	336	0.46	$M_2$				58	72	86				
			c				4.7	3.7	3.1				
			$n_{2 \text{ Eck}}$				187	202	202				
			$n_{2 \text{ th}}$				187	202	202				
20.044	350	0.46	$M_2$							104	82	193	154
			c							3.3	3.4	1.8	2.0
			$n_{2 \text{ Eck}}$							97	202	75	150
			$n_{2 \text{ th}}$							97	202	75	150
22.778	315	0.45	$M_2$			49	66	82	98	120	93	220	176
			c			5.1	3.9	3.1	2.6	2.6	2.7	1.4	1.6
			$n_{2 \text{ Eck}}$			178	165	178	178	86	178	66	132
			$n_{2 \text{ th}}$			178	165	178	178	86	178	66	132
24.933	236	0.33	$M_2$		35								
			c		5.3								
			$n_{2 \text{ Eck}}$		162								
			$n_{2 \text{ th}}$		162								
24.933	349	0.33	$M_2$			53	73	90	107				
			c			5.1	3.9	3.1	2.6				
			$n_{2 \text{ Eck}}$			162	150	162	162				
			$n_{2 \text{ th}}$			162	150	162	162				

$M \dots$  [Nm]  
 $n \dots$  [r/min]  
 $J \dots$  [kgcm<sup>2</sup>]

$P \dots$  [kW]  
 $I \dots$  [A]  
 $i \dots$  [-]  
 $c \dots$  [-]

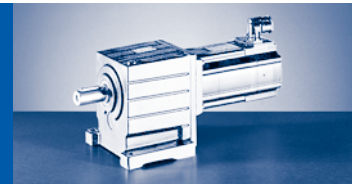

$M_{2GN} \leq 366 \text{ Nm}$

12HC35	12LC20	12LC41	14DC15	14DC36	14HC15	14HC32	14LC15	14LC32	14PC14	14PC32	GST06-2S			
...500	...500	...500	...500	...500	...500	...500	...500	...500	...500	...500				
7.50	13.50	11.00	9.20	7.50	16.00	14.00	23.00	17.20	30.00	21.00	$M_1$	$J_G$	$M_{2GN}$	i
3525	1950	4050	1500	3600	1500	3225	1500	3225	1350	3225	$n_1$			
	11.8										$I_{M230}$			
5.7	5.9	10.2	4.5	7.5	6.6	11.9	9.7	15.0	10.8	15.6	$I_{M400}$			
2.80	2.80	4.70	1.45	2.80	2.50	4.70	3.60	5.80	4.20	7.10	$P_N$			
7.42	10.72	10.72	8.22	8.22	14.32	14.32	23.44	23.44	34.74	34.82	$J_M$			
64	117	95	79	64	139	122	200	150		183	$M_2$			
3.0	2.0	2.0	3.2	3.0	1.9	1.7	1.3	1.4		1.1	c	1.50	261	9.010
391	216	450	167	400	167	358	167	358		358	$n_2 \text{ Eck}$			
344	216	312	166	343	166	283	166	253		229	$n_2 \text{ th}$			
											$M_2$			
											c	0.82	209	10.000
											$n_2 \text{ Eck}$			
											$n_2 \text{ th}$			
71	130	106	87	71	154	135	223	166		204	$M_2$			
2.8	1.9	1.8	3.0	2.8	1.7	1.5	1.2	1.3		1.0	c	0.82	269	10.000
353	195	405	150	360	150	323	150	323		323	$n_2 \text{ Eck}$			
353	195	370	150	359	150	323	150	306		280	$n_2 \text{ th}$			
80	146	119	98	80	173	151	250	187			$M_2$			
2.6	1.8	1.7	2.8	2.6	1.6	1.4	1.1	1.2			c	1.26	280	11.200
315	174	362	134	321	134	288	134	288			$n_2 \text{ Eck}$			
278	174	240	134	278	134	220	134	199			$n_2 \text{ th}$			
90	164	133	110	90	194	170	280	210			$M_2$			
2.4	1.6	1.6	2.6	2.4	1.5	1.3	1.1	1.1			c	0.96	295	12.571
280	155	322	119	286	119	257	119	257			$n_2 \text{ Eck}$			
272	155	234	119	271	119	217	119	199			$n_2 \text{ th}$			
103	186	152	126	103	221	194					$M_2$			
2.2	1.5	1.4	2.4	2.2	1.4	1.2					c	0.93	307	14.286
247	137	284	105	252	105	226					$n_2 \text{ Eck}$			
235	137	197	105	235	105	184					$n_2 \text{ th}$			
110	201	163	136	110	238	208		257			$M_2$			
2.4	1.6	1.6	2.3	2.4	1.3	1.3		1.1			c	0.75	318	15.400
229	127	263	97	234	97	209		209			$n_2 \text{ Eck}$			
229	127	223	97	233	97	205		187			$n_2 \text{ th}$			
126	228	186	155	126	271	237					$M_2$			
2.1	1.4	1.4	2.0	2.1	1.2	1.2					c	0.73	313	17.500
201	111	231	86	206	86	184					$n_2 \text{ Eck}$			
201	111	183	86	205	86	169					$n_2 \text{ th}$			
											$M_2$			
											c	0.46	336	20.044
											$n_2 \text{ Eck}$			
											$n_2 \text{ th}$			
144	262	213									$M_2$			
2.1	1.3	1.3									c	0.46	350	20.044
176	97	202									$n_2 \text{ Eck}$			
176	97	186									$n_2 \text{ th}$			
165	298	243									$M_2$			
1.6	1.1	1.1									c	0.45	315	22.778
155	86	178									$n_2 \text{ Eck}$			
155	86	150									$n_2 \text{ th}$			
											$M_2$			
											c	0.33	236	24.933
											$n_2 \text{ Eck}$			
											$n_2 \text{ th}$			
											$M_2$			
											c	0.33	349	24.933
											$n_2 \text{ Eck}$			
											$n_2 \text{ th}$			

M ... [Nm]  
n ... [r/min]  
J ... [kgcm<sup>2</sup>]

P ... [kW]  
I ... [A]  
i [-]  
c [-]

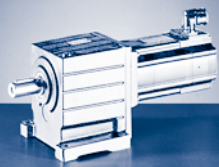

# GST [Nm]

## GST□□-□S (MCS)

$M_{2GN} \leq 366 \text{ Nm}$

GST06-2S				06FC41	06IC41	09DC41	09FC38	09HC41	09LC41	12DC20	12DC41	12HC15	12HC30	
				...500	...500	...500	...500	...500	...500	...500	...500	...500	...500	
i	$M_{2GN}$	$J_G$	$M_1$	1.20	1.50	2.30	3.10	3.80	4.50	5.50	4.30	10.00	8.00	
			$n_1$	4050	4050	4050	3750	4050	4050	1950	4050	1500	3000	
			$I_{M230}$	2.9	3.2	4.6	5.0	6.8	8.4	5.2	8.8	7.6	10.5	
			$I_{M400}$	1.5	1.6	2.3	2.5	3.4	4.2	2.6	4.5	3.8		
			$P_N$	0.51	0.64	1.00	1.20	1.60	1.90	1.10	1.80	1.60	2.50	
			$J_M$	0.25	0.33	1.13	1.53	1.93	2.83	4.12	4.12	7.42	7.42	
24.933	360	0.33	$M_2$							131	102	241	192	
			c							2.7	2.8	1.5	1.7	
			$n_{2 \text{ Eck}}$								78	162	60	120
			$n_{2 \text{ th}}$								78	162	60	120
28.333	268	0.33	$M_2$		39									
			c		5.3									
			$n_{2 \text{ Eck}}$		143									
			$n_{2 \text{ th}}$		143									
28.333	317	0.33	$M_2$			61	83	103	122	149	117	274	219	
			c			4.1	3.1	2.5	2.1	2.1	2.2	1.2	1.3	
			$n_{2 \text{ Eck}}$			143	132	143	143	69	143	53	106	
			$n_{2 \text{ th}}$			143	132	143	143	69	143	53	106	
32.267	245	0.22	$M_2$	36	45									
			c	5.3	4.3									
			$n_{2 \text{ Eck}}$	126	126									
			$n_{2 \text{ th}}$	126	126									
32.267	362	0.22	$M_2$			70	95	117	139					
			c			4.1	3.1	2.5	2.1					
			$n_{2 \text{ Eck}}$			126	116	126	126					
			$n_{2 \text{ th}}$			126	116	126	126					
36.667	278	0.22	$M_2$	41	52									
			c	5.3	4.3									
			$n_{2 \text{ Eck}}$	111	111									
			$n_{2 \text{ th}}$	110	110									
36.667	322	0.22	$M_2$			80	109	134	159					
			c			3.2	2.4	1.9	1.6					
			$n_{2 \text{ Eck}}$			111	102	111	111					
			$n_{2 \text{ th}}$			110	102	110	110					
39.160	247	0.16	$M_2$	44	55									
			c	4.4	3.5									
			$n_{2 \text{ Eck}}$	103	103									
			$n_{2 \text{ th}}$	103	103									
39.160	366	0.16	$M_2$			85	116	143	170					
			c			3.4	2.6	2.1	1.8					
			$n_{2 \text{ Eck}}$			103	96	103	103					
			$n_{2 \text{ th}}$			103	96	103	103					
44.500	281	0.16	$M_2$	50	63									
			c	4.9	3.9									
			$n_{2 \text{ Eck}}$	91	91									
			$n_{2 \text{ th}}$	91	91									
44.500	325	0.16	$M_2$			97	132	163	193					
			c			3.0	2.3	1.8	1.5					
			$n_{2 \text{ Eck}}$			91	84	91	91					
			$n_{2 \text{ th}}$			91	84	91	91					
49.500	245	0.11	$M_2$	56	71									
			c	3.8	3.1									
			$n_{2 \text{ Eck}}$	82	82									
			$n_{2 \text{ th}}$	82	82									
56.250	278	0.11	$M_2$	64	80									
			c	3.8	3.1									
			$n_{2 \text{ Eck}}$	72	72									
			$n_{2 \text{ th}}$	72	72									

$M \dots$  [Nm]  
 $n \dots$  [r/min]  
 $J \dots$  [kgcm<sup>2</sup>]

$P \dots$  [kW]  
 $I \dots$  [A]  
 $i \dots$  [-]  
 $c \dots$  [-]

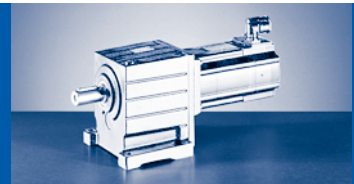

$M_{2GN} \leq 366 \text{ Nm}$

12HC35	12LC20	12LC41	14DC15	14DC36	14HC15	14HC32	14LC15	14LC32	14PC14	14PC32	GST06-2S			
...500	...500	...500	...500	...500	...500	...500	...500	...500	...500	...500	$M_1$	$J_G$	$M_{2GN}$	i
7.50	13.50	11.00	9.20	7.50	16.00	14.00	23.00	17.20	30.00	21.00	$n_1$			
3525	1950	4050	1500	3600	1500	3225	1500	3225	1350	3225	$I_{M230}$			
	11.8										$I_{M400}$			
5.7	5.9	10.2	4.5	7.5	6.6	11.9	9.7	15.0	10.8	15.6	$P_N$			
2.80	2.80	4.70	1.45	2.80	2.50	4.70	3.60	5.80	4.20	7.10	$J_M$			
7.42	10.72	10.72	8.22	8.22	14.32	14.32	23.44	23.44	34.74	34.82	$M_2$			
180	326	266									c	0.33	360	24.933
1.7	1.1	1.1									$n_{2 \text{ Eck}}$			
141	78	162									$n_{2 \text{ th}}$			
141	78	162									$M_2$	0.33	268	28.333
											c			
											$n_{2 \text{ Eck}}$			
											$n_{2 \text{ th}}$			
206											$M_2$	0.33	317	28.333
1.3											c			
124											$n_{2 \text{ Eck}}$			
124											$n_{2 \text{ th}}$			
											$M_2$	0.22	245	32.267
											c			
											$n_{2 \text{ Eck}}$			
											$n_{2 \text{ th}}$			
											$M_2$	0.22	362	32.267
											c			
											$n_{2 \text{ Eck}}$			
											$n_{2 \text{ th}}$			
											$M_2$	0.22	278	36.667
											c			
											$n_{2 \text{ Eck}}$			
											$n_{2 \text{ th}}$			
											$M_2$	0.22	322	36.667
											c			
											$n_{2 \text{ Eck}}$			
											$n_{2 \text{ th}}$			
											$M_2$	0.16	247	39.160
											c			
											$n_{2 \text{ Eck}}$			
											$n_{2 \text{ th}}$			
											$M_2$	0.16	366	39.160
											c			
											$n_{2 \text{ Eck}}$			
											$n_{2 \text{ th}}$			
											$M_2$	0.16	281	44.500
											c			
											$n_{2 \text{ Eck}}$			
											$n_{2 \text{ th}}$			
											$M_2$	0.16	325	44.500
											c			
											$n_{2 \text{ Eck}}$			
											$n_{2 \text{ th}}$			
											$M_2$	0.11	245	49.500
											c			
											$n_{2 \text{ Eck}}$			
											$n_{2 \text{ th}}$			
											$M_2$	0.11	278	56.250
											c			
											$n_{2 \text{ Eck}}$			
											$n_{2 \text{ th}}$			

M ... [Nm]  
n ... [r/min]  
J ... [kgcm<sup>2</sup>]

P ... [kW]  
I ... [A]  
i [-]  
c [-]

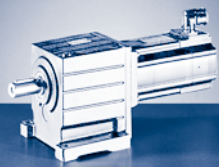

# GST [Nm]

## GST□□-□S (MCS)

$M_{2GN} \leq 375 \text{ Nm}$

GST06-3S				06CC41	06FC41	06IC41	09DC41	09FC38	09HC41	09LC41
				...500	...500	...500	...500	...500	...500	...500
i	$M_{2GN}$	$J_G$	$M_1$	0.60	1.20	1.50	2.30	3.10	3.80	4.50
			$n_1$	4050	4050	4050	4050	3750	4050	4050
			$I_{M230}$	2.6	2.9	3.2	4.6	5.0	6.8	8.4
			$I_{M400}$	1.3	1.5	1.6	2.3	2.5	3.4	4.2
			$P_N$	0.25	0.51	0.64	1.00	1.20	1.60	1.90
			$J_M$	0.17	0.25	0.33	1.13	1.53	1.93	2.83
39.200	321	0.36	$M_2$		43	54	84	115	141	168
			c		5.8	4.7	3.0	2.3	1.8	1.6
			$n_{2 \text{ Eck}}$		103	103	103	96	103	103
			$n_{2 \text{ th}}$		103	103	103	96	103	103
44.000	335	0.20	$M_2$			61	95	128	158	188
			c			4.8	3.1	2.4	1.9	1.6
			$n_{2 \text{ Eck}}$			92	92	85	92	92
			$n_{2 \text{ th}}$			92	92	85	92	92
51.022	325	0.32	$M_2$		56	71	110	150	184	219
			c		5.0	4.0	2.6	2.0	1.6	1.3
			$n_{2 \text{ Eck}}$		79	79	79	74	79	79
			$n_{2 \text{ th}}$		79	79	79	74	79	79
53.900	349	0.18	$M_2$		59	75	116	158	194	231
			c		5.1	4.1	2.7	2.0	1.6	1.4
			$n_{2 \text{ Eck}}$		75	75	75	70	75	75
			$n_{2 \text{ th}}$		75	75	75	70	75	75
67.760	365	0.11	$M_2$		75	95				
			c		4.3	3.4				
			$n_{2 \text{ Eck}}$		60	60				
			$n_{2 \text{ th}}$		60	60				
70.156	359	0.16	$M_2$		78	98	152	207	254	301
			c		4.0	3.2	2.1	1.6	1.3	1.1
			$n_{2 \text{ Eck}}$		58	58	58	54	58	58
			$n_{2 \text{ th}}$		58	58	58	53	58	58
80.952	332	0.20	$M_2$		91	114	177	239	294	
			c		3.2	2.6	1.7	1.3	1.0	
			$n_{2 \text{ Eck}}$		50	50	50	46	50	
			$n_{2 \text{ th}}$		50	50	50	46	50	
87.267	370	0.15	$M_2$		98	123	190	258	317	
			c		3.3	2.7	1.7	1.3	1.1	
			$n_{2 \text{ Eck}}$		46	46	46	43	46	
			$n_{2 \text{ th}}$		46	46	46	43	46	
99.167	336	0.15	$M_2$	54	112	140	217	294		
			c	5.3	2.7	2.1	1.4	1.1		
			$n_{2 \text{ Eck}}$	41	41	41	41	38		
			$n_{2 \text{ th}}$	41	41	41	41	38		
109.707	375	0.10	$M_2$	60	124	155				
			c	5.4	2.7	2.2				
			$n_{2 \text{ Eck}}$	37	37	37				
			$n_{2 \text{ th}}$	37	37	37				
124.667	339	0.10	$M_2$	69	141	177				
			c	4.3	2.2	1.7				
			$n_{2 \text{ Eck}}$	33	33	33				
			$n_{2 \text{ th}}$	32	32	32				
141.289	375	0.06	$M_2$	78	160	201				
			c	4.2	2.1	1.7				
			$n_{2 \text{ Eck}}$	29	29	29				
			$n_{2 \text{ th}}$	29	29	29				
160.556	342	0.06	$M_2$	90	183	229				
			c	3.4	1.7	1.3				
			$n_{2 \text{ Eck}}$	25	25	25				
			$n_{2 \text{ th}}$	25	25	25				

$M \dots$  [Nm]  
 $n \dots$  [r/min]  
 $J \dots$  [kgcm<sup>2</sup>]

$P \dots$  [kW]  
 $I \dots$  [A]  
 $i \dots$  [-]  
 $c \dots$  [-]

**GST [Nm]**  
GST□□-□S (MCS)

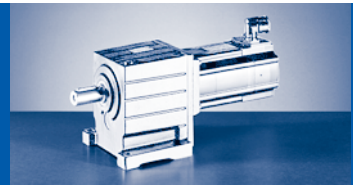

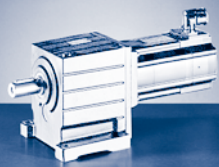

# GST [Nm]

## GST□□-□S (MCS)

$M_{2GN} \leq 196 \text{ Nm}$

GST07-1S				09DC41	09FC38	09HC41	09LC41	12DC20	12DC41	12HC15	12HC30	12HC35	12LC20	12LC41	14DC15	
				...S00	...S00	...S00	...S00	...S00	...S00	...S00	...S00	...S00	...S00	...S00	...S00	
i	$M_{2GN}$	$J_G$	$M_1$	2.30	3.10	3.80	4.50	5.50	4.30	10.00	8.00	7.50	13.50	11.00	9.20	
			$n_1$	4050	3750	4050	4050	1950	4050	1500	3000	3525	1950	4050	1500	
			$I_{M230}$	4.6	5.0	6.8	8.4	5.2	8.8	7.6	10.5		11.8			
			$I_{M400}$	2.3	2.5	3.4	4.2	2.6	4.5	3.8		5.7	5.9	10.2	4.5	
			$P_N$	1.00	1.20	1.60	1.90	1.10	1.80	1.60	2.50	2.80	2.80	4.70	1.45	
			$J_M$	1.13	1.53	1.93	2.83	4.12	4.12	7.42	7.42	7.42	10.72	10.72	8.22	
1.625	106	6.12	$M_2$ c $n_{2 \text{ Eck}}$ $n_{2 \text{ th}}$													
2.000	99	4.78	$M_2$ c $n_{2 \text{ Eck}}$ $n_{2 \text{ th}}$							19 5.0 750 750	15 5.0 1500 1422	14 5.1 1763 1425	26 3.4 975 975	21 3.3 2025 1303		
2.000	124	4.78	$M_2$ c $n_{2 \text{ Eck}}$ $n_{2 \text{ th}}$													
2.240	105	4.02	$M_2$ c $n_{2 \text{ Eck}}$ $n_{2 \text{ th}}$							21 4.8 670 670	17 4.7 1339 1306	16 4.8 1574 1308	29 3.2 871 871	24 3.1 1808 1199		
2.240	135	4.02	$M_2$ c $n_{2 \text{ Eck}}$ $n_{2 \text{ th}}$													
2.857	88	2.69	$M_2$ c $n_{2 \text{ Eck}}$ $n_{2 \text{ th}}$			10 5.9 1418 1243	12 5.0 1418 1206									
2.857	113	2.69	$M_2$ c $n_{2 \text{ Eck}}$ $n_{2 \text{ th}}$							27 4.0 525 525	22 4.0 1050 1050	20 4.0 1234 1158	37 2.7 683 683	30 2.6 1418 1062		
2.857	156	2.69	$M_2$ c $n_{2 \text{ Eck}}$ $n_{2 \text{ th}}$													
3.500	119	2.15	$M_2$ c $n_{2 \text{ Eck}}$ $n_{2 \text{ th}}$					18 5.7 557 557	14 5.8 1157 1093	34 3.5 429 429	27 3.4 857 857	25 3.5 1007 1000	46 2.3 557 557	37 2.3 1157 922		
3.500	172	2.15	$M_2$ c $n_{2 \text{ Eck}}$ $n_{2 \text{ th}}$												30 5.4 429 429	
4.556	96	1.37	$M_2$ c $n_{2 \text{ Eck}}$ $n_{2 \text{ th}}$		13 5.1 823 823	17 4.1 889 889	20 3.4 889 889									
4.556	124	1.37	$M_2$ c $n_{2 \text{ Eck}}$ $n_{2 \text{ th}}$					24 4.6 428 428	19 4.6 889 889	44 2.8 329 329	35 2.7 659 659	33 2.8 774 774	60 1.9 428 428	49 1.8 889 804		
4.556	186	1.37	$M_2$ c $n_{2 \text{ Eck}}$ $n_{2 \text{ th}}$												40 4.5 329 329	

$M \dots$  [Nm]  
 $n \dots$  [r/min]  
 $J \dots$  [kgcm<sup>2</sup>]

$P \dots$  [kW]  
 $I \dots$  [A]  
 $i \dots$  [-]  
 $c \dots$  [-]

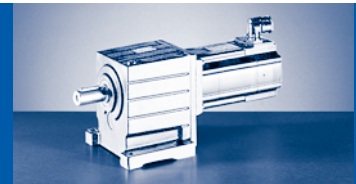

$M_{2GN} \leq 196 \text{ Nm}$

14DC36	14HC15	14HC32	14LC15	14LC32	14PC14	14PC32	19FC14	19FC30	19JC14	19JC30	19PC14	19PC30	GST07-1S			
...500	...500	...500	...500	...500	...500	...500	...500	...500	...500	...500	...500	...500	$M_1$	$J_G$	$M_{2GN}$	i
7.50	16.00	14.00	23.00	17.20	30.00	21.00	27.00	21.00	40.00	29.00	51.00	32.00	$n_1$			
3600	1500	3225	1500	3225	1350	3225	1425	3000	1425	3000	1350	3000	$I_{M230}$			
													$I_{M400}$			
7.5	6.6	11.9	9.7	15.0	10.8	15.6	8.6	14.0	12.3	18.5	14.3	19.0	$P_N$			
2.80	2.50	4.70	3.60	5.80	4.20	7.10	4.00	6.60	6.00	9.10	7.20	10.00	$J_M$			
8.22	14.32	14.32	23.44	23.44	34.74	34.82	65.12	65.04	105.04	105.12	160.12	160.04	$M_2$			
	25	22	36	27	47	33	43	33	64	46	81	51	c	6.12	106	1.625
	4.1	3.7	2.9	3.0	2.2	2.5	2.5	2.5	1.7	1.8	1.3	1.6	$n_{2 \text{ Eck}}$			
	923	1985	923	1985	831	1985	877	1846	877	1846	831	1846	$n_{2 \text{ th}}$			
													$M_2$	4.78	99	2.000
													c			
													$n_{2 \text{ Eck}}$			
	31	27	45	33	58	41	52	41	78	57	100	63	$M_2$	4.78	124	2.000
	3.9	3.5	2.7	2.8	2.1	2.3	2.3	2.4	1.6	1.7	1.2	1.6	c			
	750	1613	750	1613	675	1613	713	1500	713	1500	675	1500	$n_{2 \text{ Eck}}$			
	750	1319	750	1260	675	1203	713	1105	713	1065	675	1006	$n_{2 \text{ th}}$			
													$M_2$	4.02	105	2.240
													c			
													$n_{2 \text{ Eck}}$			
	34	30	50	37	65	46	59	46	88	64	112	70	$M_2$	4.02	135	2.240
	3.8	3.4	2.7	2.8	2.0	2.3	2.3	2.3	1.5	1.7	1.2	1.5	c			
	670	1440	670	1440	603	1440	636	1339	636	1339	603	1339	$n_{2 \text{ Eck}}$			
	670	1220	670	1167	603	1117	636	987	636	984	603	932	$n_{2 \text{ th}}$			
													$M_2$	2.69	88	2.857
													c			
													$n_{2 \text{ Eck}}$			
													$M_2$	2.69	113	2.857
													c			
													$n_{2 \text{ Eck}}$			
20	44	39	64	48	84	58							$M_2$	2.69	156	2.857
5.5	3.5	3.1	2.4	2.5	1.9	2.1							c			
1260	525	1129	525	1129	473	1129							$n_{2 \text{ Eck}}$			
1229	525	1098	525	1051	473	1007							$n_{2 \text{ th}}$			
													$M_2$	2.15	119	3.500
													c			
													$n_{2 \text{ Eck}}$			
25	54	47	78	59	103	72							$M_2$	2.15	172	3.500
5.0	3.1	2.8	2.2	2.3	1.7	1.8							c			
1029	429	921	429	921	386	921							$n_{2 \text{ Eck}}$			
1026	429	921	429	921	386	865							$n_{2 \text{ th}}$			
													$M_2$	1.37	96	4.556
													c			
													$n_{2 \text{ Eck}}$			
													$M_2$	1.37	124	4.556
													c			
													$n_{2 \text{ Eck}}$			
33	71	62	102	77	134	94							$M_2$	1.37	186	4.556
4.1	2.6	2.3	1.8	1.9	1.4	1.5							c			
790	329	708	329	708	296	708							$n_{2 \text{ Eck}}$			
788	329	708	329	708	296	708							$n_{2 \text{ th}}$			

$M \dots$  [Nm]  
 $n \dots$  [r/min]  
 $J \dots$  [kgcm<sup>2</sup>]

$P \dots$  [kW]  
 $I \dots$  [A]  
 $i$  [-]  
 $c$  [-]

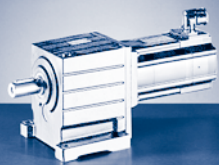

# GST [Nm]

## GST□□-□S (MCS)

$M_{2GN} \leq 196 \text{ Nm}$

GST07-1S				09DC41	09FC38	09HC41	09LC41	12DC20	12DC41	12HC15	12HC30	12HC35	12LC20	12LC41	14DC15	
				...S00	...S00	...S00	...S00	...S00	...S00	...S00	...S00	...S00	...S00	...S00	...S00	
i	$M_{2GN}$	$J_G$	$M_1$	2.30	3.10	3.80	4.50	5.50	4.30	10.00	8.00	7.50	13.50	11.00	9.20	
			$n_1$	4050	3750	4050	4050	1950	4050	1500	3000	3525	1950	4050	1500	
			$I_{M230}$	4.6	5.0	6.8	8.4	5.2	8.8	7.6	10.5		11.8			
			$I_{M400}$	2.3	2.5	3.4	4.2	2.6	4.5	3.8		5.7	5.9	10.2	4.5	
			$P_N$	1.00	1.20	1.60	1.90	1.10	1.80	1.60	2.50	2.80	2.80	4.70	1.45	
			$J_M$	1.13	1.53	1.93	2.83	4.12	4.12	7.42	7.42	7.42	10.72	10.72	8.22	
5.583	101	1.05	$M_2$	12	16	20	24									
			c	5.7	4.4	3.5	2.9									
			$n_{2 \text{ Eck}}$	725	672	725	725									
			$n_{2 \text{ th}}$	725	672	725	725									
5.583	130	1.05	$M_2$					29	23	54	43	41	74	60		
			c					3.9	4.0	2.4	2.4	2.4	1.6	1.5		
			$n_{2 \text{ Eck}}$					349	725	269	537	631	349	725		
			$n_{2 \text{ th}}$					349	725	269	537	631	349	682		
5.583	196	1.05	$M_2$												49	
			c												3.9	
			$n_{2 \text{ Eck}}$												269	
			$n_{2 \text{ th}}$												269	
7.333	104	0.66	$M_2$	16	22	27	32									
			c	4.5	3.4	2.7	2.3									
			$n_{2 \text{ Eck}}$	552	511	552	552									
			$n_{2 \text{ th}}$	552	511	552	552									
7.333	134	0.66	$M_2$					39	30	72	57	54	97	79		
			c					3.1	3.1	1.9	1.8	1.9	1.3	1.2		
			$n_{2 \text{ Eck}}$					266	552	205	409	481	266	552		
			$n_{2 \text{ th}}$					266	552	205	409	481	266	552		
8.900	105	0.49	$M_2$	20	27	33	39									
			c	3.7	2.9	2.3	1.9									
			$n_{2 \text{ Eck}}$	455	421	455	455									
			$n_{2 \text{ th}}$	455	421	455	455									
8.900	135	0.49	$M_2$					47	37	87	70	65	118	96		
			c					2.6	2.6	1.5	1.5	1.6	1.1	1.0		
			$n_{2 \text{ Eck}}$					219	455	169	337	396	219	455		
			$n_{2 \text{ th}}$					219	455	169	337	396	219	455		
11.250	106	0.32	$M_2$	25	34	42	50									
			c	3.0	2.3	1.8	1.5									
			$n_{2 \text{ Eck}}$	360	333	360	360									
			$n_{2 \text{ th}}$	360	333	360	360									

M ... [Nm]  
 n ... [r/min]  
 J ... [kgcm<sup>2</sup>]

P ... [kW]  
 I ... [A]  
 i [-]  
 c [-]

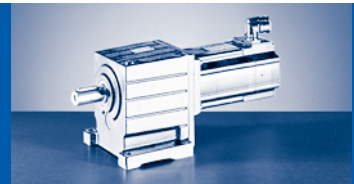

$M_{2GN} \leq 196 \text{ Nm}$

14DC36	14HC15	14HC32	14LC15	14LC32	14PC14	14PC32	19FC14	19FC30	19JC14	19JC30	19PC14	19PC30	GST07-1S			
...500	...500	...500	...500	...500	...500	...500	...500	...500	...500	...500	...500	...500	$M_1$	$J_G$	$M_{2GN}$	i
7.50	16.00	14.00	23.00	17.20	30.00	21.00	27.00	21.00	40.00	29.00	51.00	32.00	$n_1$			
3600	1500	3225	1500	3225	1350	3225	1425	3000	1425	3000	1350	3000	$I_{M230}$			
													$I_{M400}$			
7.5	6.6	11.9	9.7	15.0	10.8	15.6	8.6	14.0	12.3	18.5	14.3	19.0	$P_N$			
2.80	2.50	4.70	3.60	5.80	4.20	7.10	4.00	6.60	6.00	9.10	7.20	10.00	$J_M$			
8.22	14.32	14.32	23.44	23.44	34.74	34.82	65.12	65.04	105.04	105.12	160.12	160.04	$M_2$			
													c			
													$n_2$	1.05	101	5.583
													Eck			
													$n_2$			
													th			
													$M_2$			
													c			
													$n_2$	1.05	130	5.583
													Eck			
													$n_2$			
													th			
40	87	76	126	94	165	115							$M_2$			
3.6	2.2	2.0	1.6	1.6	1.2	1.3							c			
645	269	578	269	578	242	578							$n_2$	1.05	196	5.583
643	269	578	269	578	242	578							Eck			
													$n_2$			
													th			
													$M_2$			
													c			
													$n_2$	0.66	104	7.333
													Eck			
													$n_2$			
													th			
													$M_2$			
													c			
													$n_2$	0.66	134	7.333
													Eck			
													$n_2$			
													th			
													$M_2$			
													c			
													$n_2$	0.49	105	8.900
													Eck			
													$n_2$			
													th			
													$M_2$			
													c			
													$n_2$	0.49	135	8.900
													Eck			
													$n_2$			
													th			
													$M_2$			
													c			
													$n_2$	0.32	106	11.250
													Eck			
													$n_2$			
													th			

M ... [Nm]  
n ... [r/min]  
J ... [kgcm<sup>2</sup>]

P ... [kW]  
I ... [A]  
i [-]  
c [-]

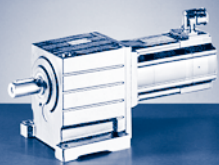

# GST [Nm]

## GST□□-□S (MCS)

$M_{2GN} \leq 706 \text{ Nm}$

GST07-2S				09DC41	09FC38	09HC41	09LC41	12DC20	12DC41	12HC15	12HC30	12HC35	12LC20	12LC41	14DC15
				...S00	...S00	...S00	...S00	...S00	...S00	...S00	...S00	...S00	...S00	...S00	...S00
i	$M_{2GN}$	$J_G$	$M_1$	2.30	3.10	3.80	4.50	5.50	4.30	10.00	8.00	7.50	13.50	11.00	9.20
			$n_1$	4050	3750	4050	4050	1950	4050	1500	3000	3525	1950	4050	1500
			$I_{M230}$	4.6	5.0	6.8	8.4	5.2	8.8	7.6	10.5		11.8		
			$I_{M400}$	2.3	2.5	3.4	4.2	2.6	4.5	3.8		5.7	5.9	10.2	4.5
			$P_N$	1.00	1.20	1.60	1.90	1.10	1.80	1.60	2.50	2.80	2.80	4.70	1.45
			$J_M$	1.13	1.53	1.93	2.83	4.12	4.12	7.42	7.42	7.42	10.72	10.72	8.22
3.048	304	8.20	$M_2$ c $n_{2 \text{ Eck}}$ $n_{2 \text{ th}}$												
3.048	351	8.20	$M_2$ c $n_{2 \text{ Eck}}$ $n_{2 \text{ th}}$												
3.350	334	7.92	$M_2$ c $n_{2 \text{ Eck}}$ $n_{2 \text{ th}}$												
3.350	367	7.92	$M_2$ c $n_{2 \text{ Eck}}$ $n_{2 \text{ th}}$												
4.225	373	7.65	$M_2$ c $n_{2 \text{ Eck}}$ $n_{2 \text{ th}}$												
4.225	398	7.65	$M_2$ c $n_{2 \text{ Eck}}$ $n_{2 \text{ th}}$												
4.643	410	7.39	$M_2$ c $n_{2 \text{ Eck}}$ $n_{2 \text{ th}}$												
4.643	414	7.39	$M_2$ c $n_{2 \text{ Eck}}$ $n_{2 \text{ th}}$												
5.200	254	5.64	$M_2$ c $n_{2 \text{ Eck}}$ $n_{2 \text{ th}}$							48 5.0 289 288	39 5.0 577 547	36 5.1 678 548	66 3.4 375 375	54 3.3 779 501	
5.200	399	5.64	$M_2$ c $n_{2 \text{ Eck}}$ $n_{2 \text{ th}}$												
5.200	427	5.64	$M_2$ c $n_{2 \text{ Eck}}$ $n_{2 \text{ th}}$												
5.714	279	5.46	$M_2$ c $n_{2 \text{ Eck}}$ $n_{2 \text{ th}}$							53 5.0 263 263	43 5.0 525 498	40 5.1 617 499	73 3.4 341 341	60 3.3 709 456	
5.714	438	5.46	$M_2$ c $n_{2 \text{ Eck}}$ $n_{2 \text{ th}}$												

M ... [Nm]  
n ... [r/min]  
J ... [kgcm<sup>2</sup>]

P ... [kW]  
I ... [A]  
i [-]  
c [-]

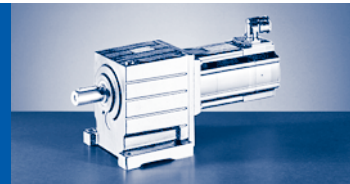

$M_{2GN} \leq 706 \text{ Nm}$

14DC36	14HC15	14HC32	14LC15	14LC32	14PC14	14PC32	19FC14	19FC30	19JC14	19JC30	19PC14	19PC30	GST07-2S			
...500	...500	...500	...500	...500	...500	...500	...500	...500	...500	...500	...500	...500	$M_1$	$J_G$	$M_{2GN}$	i
7.50	16.00	14.00	23.00	17.20	30.00	21.00	27.00	21.00	40.00	29.00	51.00	32.00	$n_1$			
3600	1500	3225	1500	3225	1350	3225	1425	3000	1425	3000	1350	3000	$I_{M230}$			
													$I_{M400}$			
7.5	6.6	11.9	9.7	15.0	10.8	15.6	8.6	14.0	12.3	18.5	14.3	19.0	$P_N$			
2.80	2.50	4.70	3.60	5.80	4.20	7.10	4.00	6.60	6.00	9.10	7.20	10.00	$J_M$			
8.22	14.32	14.32	23.44	23.44	34.74	34.82	65.12	65.04	105.04	105.12	160.12	160.04	$M_2$			
		39	66	49	87	60							c	8.20	304	3.048
		5.7	4.5	4.6	3.4	3.8							$n_{2\text{ Eck}}$			
		1058	492	1058	443	1058							$n_{2\text{ th}}$			
		738	492	706	443	675										
							77	60	116	84	149	93	$M_2$	8.20	351	3.048
							4.4	4.5	3.0	3.3	2.3	3.0	c			
							468	984	468	984	443	984	$n_{2\text{ Eck}}$			
							467	701	467	652	443	636	$n_{2\text{ th}}$			
		43	72	54	95	66							$M_2$	7.92	334	3.350
		5.7	4.5	4.6	3.4	3.8							c			
		963	448	963	403	963							$n_{2\text{ Eck}}$			
		671	448	643	403	615							$n_{2\text{ th}}$			
							85	66	128	92	164	102	$M_2$	7.92	367	3.350
							4.2	4.3	2.8	3.1	2.2	2.8	c			
							425	896	425	896	403	896	$n_{2\text{ Eck}}$			
							425	631	425	586	403	572	$n_{2\text{ th}}$			
	62	55	91	68	120	84							$M_2$	7.65	373	4.225
	5.7	5.0	4.0	4.1	3.0	3.4							c			
	355	763	355	763	320	763							$n_{2\text{ Eck}}$			
	355	596	355	571	320	547							$n_{2\text{ th}}$			
							108	84	162	117	207	129	$M_2$	7.65	398	4.225
							3.6	3.7	2.4	2.7	1.9	2.4	c			
							337	710	337	710	320	710	$n_{2\text{ Eck}}$			
							337	523	337	519	320	507	$n_{2\text{ th}}$			
	69	60	100	75	132	92							$M_2$	7.39	410	4.643
	5.7	5.0	4.0	4.1	3.0	3.4							c			
	323	695	323	695	291	695							$n_{2\text{ Eck}}$			
	323	543	323	520	291	498							$n_{2\text{ th}}$			
							119	92	178	129	228	142	$M_2$	7.39	414	4.643
							3.4	3.5	2.3	2.5	1.8	2.3	c			
							307	646	307	646	291	646	$n_{2\text{ Eck}}$			
							307	476	307	466	291	456	$n_{2\text{ th}}$			
													$M_2$	5.64	254	5.200
													c			
													$n_{2\text{ Eck}}$			
													$n_{2\text{ th}}$			
	77	68	113	84	149	104							$M_2$	5.64	399	5.200
	4.9	4.4	3.4	3.6	2.6	2.9							c			
	289	620	289	620	260	620							$n_{2\text{ Eck}}$			
	288	532	288	510	260	488							$n_{2\text{ th}}$			
							133	104	199	144	256	160	$M_2$	5.64	427	5.200
							3.1	3.2	2.1	2.3	1.7	2.1	c			
							274	577	274	577	260	577	$n_{2\text{ Eck}}$			
							274	425	274	425	260	425	$n_{2\text{ th}}$			
													$M_2$	5.46	279	5.714
													c			
													$n_{2\text{ Eck}}$			
													$n_{2\text{ th}}$			
	85	75	124	93	164	114							$M_2$	5.46	438	5.714
	4.9	4.4	3.4	3.6	2.6	2.9							c			
	263	564	263	564	236	564							$n_{2\text{ Eck}}$			
	263	484	263	464	236	444							$n_{2\text{ th}}$			

M ... [Nm]  
n ... [r/min]  
J ... [kgcm<sup>2</sup>]

P ... [kW]  
I ... [A]  
i [-]  
c [-]

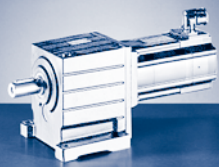

# GST [Nm]

## GST□□-□S (MCS)

$M_{2GN} \leq 706 \text{ Nm}$

GST07-2S				09DC41	09FC38	09HC41	09LC41	12DC20	12DC41	12HC15	12HC30	12HC35	12LC20	12LC41	14DC15
				...S00	...S00	...S00	...S00	...S00	...S00	...S00	...S00	...S00	...S00	...S00	...S00
i	$M_{2GN}$	$J_G$	$M_1$	2.30	3.10	3.80	4.50	5.50	4.30	10.00	8.00	7.50	13.50	11.00	9.20
			$n_1$	4050	3750	4050	4050	1950	4050	1500	3000	3525	1950	4050	1500
			$I_{M230}$	4.6	5.0	6.8	8.4	5.2	8.8	7.6	10.5		11.8		
			$I_{M400}$	2.3	2.5	3.4	4.2	2.6	4.5	3.8		5.7	5.9	10.2	4.5
			$P_N$	1.00	1.20	1.60	1.90	1.10	1.80	1.60	2.50	2.80	2.80	4.70	1.45
			$J_M$	1.13	1.53	1.93	2.83	4.12	4.12	7.42	7.42	7.42	10.72	10.72	8.22
5.714	448	5.46	$M_2$ c $n_{2 \text{ Eck}}$ $n_{2 \text{ th}}$												
6.400	296	4.49	$M_2$ c $n_{2 \text{ Eck}}$ $n_{2 \text{ th}}$							60 4.8	48 4.7	45 4.8	82 3.2	67 3.1	
6.400	460	4.49	$M_2$ c $n_{2 \text{ Eck}}$ $n_{2 \text{ th}}$							234	469	551	305	633	
6.400	463	4.49	$M_2$ c $n_{2 \text{ Eck}}$ $n_{2 \text{ th}}$							234	457	458	305	420	
7.150	489	6.27	$M_2$ c $n_{2 \text{ Eck}}$ $n_{2 \text{ th}}$												
8.125	539	6.04	$M_2$ c $n_{2 \text{ Eck}}$ $n_{2 \text{ th}}$												
8.800	430	4.73	$M_2$ c $n_{2 \text{ Eck}}$ $n_{2 \text{ th}}$							82 5.0	65 5.0	61 5.1	112 3.4	92 3.3	
8.800	527	4.73	$M_2$ c $n_{2 \text{ Eck}}$ $n_{2 \text{ th}}$							171	341	401	222	460	
9.856	456	3.90	$M_2$ c $n_{2 \text{ Eck}}$ $n_{2 \text{ th}}$							170	323	324	222	296	
9.856	549	3.90	$M_2$ c $n_{2 \text{ Eck}}$ $n_{2 \text{ th}}$												
11.200	518	3.78	$M_2$ c $n_{2 \text{ Eck}}$ $n_{2 \text{ th}}$							92 4.8	74 4.7	69 4.8	126 3.2	103 3.1	
11.200	598	3.78	$M_2$ c $n_{2 \text{ Eck}}$ $n_{2 \text{ th}}$							152	304	358	198	411	
12.571	380	2.86	$M_2$ c $n_{2 \text{ Eck}}$ $n_{2 \text{ th}}$			44 5.9 322 283	53 5.0 322 274			152	297	297	198	273	

$M \dots$  [Nm]  
 $n \dots$  [r/min]  
 $J \dots$  [kgcm<sup>2</sup>]

$P \dots$  [kW]  
 $I \dots$  [A]  
 $i \dots$  [-]  
 $c \dots$  [-]

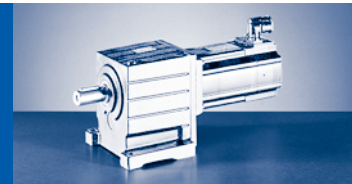

$M_{2GN} \leq 706 \text{ Nm}$

14DC36	14HC15	14HC32	14LC15	14LC32	14PC14	14PC32	19FC14	19FC30	19JC14	19JC30	19PC14	19PC30	GST07-2S			
...500	...500	...500	...500	...500	...500	...500	...500	...500	...500	...500	...500	...500	$M_1$	$J_G$	$M_{2GN}$	i
7.50	16.00	14.00	23.00	17.20	30.00	21.00	27.00	21.00	40.00	29.00	51.00	32.00	$n_1$			
3600	1500	3225	1500	3225	1350	3225	1425	3000	1425	3000	1350	3000	$I_{M230}$			
													$I_{M400}$			
7.5	6.6	11.9	9.7	15.0	10.8	15.6	8.6	14.0	12.3	18.5	14.3	19.0	$P_N$			
2.80	2.50	4.70	3.60	5.80	4.20	7.10	4.00	6.60	6.00	9.10	7.20	10.00	$J_M$			
8.22	14.32	14.32	23.44	23.44	34.74	34.82	65.12	65.04	105.04	105.12	160.12	160.04	$M_2$			
							147	114	219	159	281	176	c	5.46	448	5.714
							3.0	3.1	2.0	2.2	1.6	2.0	$n_{2 \text{ Eck}}$			
							249	525	249	525	236	525	$n_{2 \text{ th}}$			
							249	387	249	387	236	387	$M_2$			
													c	4.49	296	6.400
													$n_{2 \text{ Eck}}$			
													$n_{2 \text{ th}}$			
	96	84	140	104	183	128							$M_2$			
	4.6	4.1	3.2	3.3	2.5	2.7							c	4.49	460	6.400
	234	504	234	504	211	504							$n_{2 \text{ Eck}}$			
	234	444	234	426	211	408							$n_{2 \text{ th}}$			
							165	128	246	178	315	197	$M_2$			
							2.8	2.8	1.9	2.0	1.5	1.9	c	4.49	463	6.400
							223	469	223	469	211	469	$n_{2 \text{ Eck}}$			
							223	345	223	345	211	345	$n_{2 \text{ th}}$			
	107	94	156	117	205	143	184	143	275	199	352	220	$M_2$			
	4.4	3.9	3.1	3.2	2.4	2.6	2.6	2.7	1.8	1.9	1.4	1.8	c	6.27	489	7.150
	210	451	210	451	189	451	199	420	199	420	189	420	$n_{2 \text{ Eck}}$			
	210	334	210	319	189	305	199	307	199	282	189	266	$n_{2 \text{ th}}$			
	122	107	178	133	233	163	209	163	313	227	401	250	$M_2$			
	4.3	3.8	3.0	3.1	2.3	2.5	2.5	2.6	1.7	1.9	1.3	1.7	c	6.04	539	8.125
	185	397	185	397	166	397	175	369	175	369	166	369	$n_{2 \text{ Eck}}$			
	185	292	185	279	166	267	175	268	175	244	166	230	$n_{2 \text{ th}}$			
													$M_2$			
													c	4.73	430	8.800
													$n_{2 \text{ Eck}}$			
													$n_{2 \text{ th}}$			
	133	117	193	144	253	177	227	177	340	246	434	272	$M_2$			
	3.9	3.4	2.7	2.8	2.1	2.3	2.3	2.3	1.5	1.7	1.2	1.5	c	4.73	527	8.800
	171	367	171	367	153	367	162	341	162	341	153	341	$n_{2 \text{ Eck}}$			
	170	299	170	285	153	272	162	251	162	240	153	226	$n_{2 \text{ th}}$			
													$M_2$			
													c	3.90	456	9.856
													$n_{2 \text{ Eck}}$			
													$n_{2 \text{ th}}$			
68	149	131	217	162	284	198	255	198	381	276	487	305	$M_2$			
5.7	3.6	3.2	2.5	2.6	1.9	2.1	2.1	2.2	1.4	1.6	1.1	1.4	c	3.90	549	9.856
365	152	327	152	327	137	327	145	304	145	304	137	304	$n_{2 \text{ Eck}}$			
308	152	274	152	262	137	250	145	224	145	216	137	205	$n_{2 \text{ th}}$			
													$M_2$			
													c	3.78	518	11.200
													$n_{2 \text{ Eck}}$			
													$n_{2 \text{ th}}$			
78	169	149	246	184	323	226	290	226	433	313	554	346	$M_2$			
5.5	3.4	3.1	2.4	2.5	1.8	2.0	2.0	2.1	1.4	1.5	1.1	1.4	c	3.78	598	11.200
321	134	288	134	288	121	288	127	268	127	268	121	268	$n_{2 \text{ Eck}}$			
269	134	239	134	228	121	218	127	197	127	186	121	177	$n_{2 \text{ th}}$			
													$M_2$			
													c	2.86	380	12.571
													$n_{2 \text{ Eck}}$			
													$n_{2 \text{ th}}$			

M ... [Nm]  
n ... [r/min]  
J ... [kgcm<sup>2</sup>]

P ... [kW]  
I ... [A]  
i [-]  
c [-]

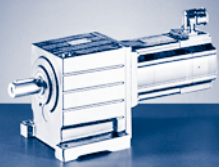

# GST [Nm]

## GST□□-□S (MCS)

$M_{2GN} \leq 706 \text{ Nm}$

GST07-2S				09DC41	09FC38	09HC41	09LC41	12DC20	12DC41	12HC15	12HC30	12HC35	12LC20	12LC41	14DC15
				...S00	...S00	...S00	...S00	...S00	...S00	...S00	...S00	...S00	...S00	...S00	...S00
i	$M_{2GN}$	$J_G$	$M_1$	2.30	3.10	3.80	4.50	5.50	4.30	10.00	8.00	7.50	13.50	11.00	9.20
			$n_1$	4050	3750	4050	4050	1950	4050	1500	3000	3525	1950	4050	1500
			$I_{M230}$	4.6	5.0	6.8	8.4	5.2	8.8	7.6	10.5		11.8		
			$I_{M400}$	2.3	2.5	3.4	4.2	2.6	4.5	3.8		5.7	5.9	10.2	4.5
			$P_N$	1.00	1.20	1.60	1.90	1.10	1.80	1.60	2.50	2.80	2.80	4.70	1.45
			$J_M$	1.13	1.53	1.93	2.83	4.12	4.12	7.42	7.42	7.42	10.72	10.72	8.22
12.571	489	2.86	$M_2$							118	95	89	162	132	
			c							4.0	4.0	4.0	2.7	2.6	
			$n_{2 \text{ Eck}}$							119	239	280	155	322	
			$n_{2 \text{ th}}$							119	239	263	155	241	
12.571	601	2.86	$M_2$												107
			c												5.4
			$n_{2 \text{ Eck}}$												119
			$n_{2 \text{ th}}$												119
14.286	432	2.79	$M_2$			50	60								
			c			5.9	5.0								
			$n_{2 \text{ Eck}}$			284	284								
			$n_{2 \text{ th}}$			249	241								
14.286	556	2.79	$M_2$							134	107	101	184	150	
			c							4.0	4.0	4.0	2.7	2.6	
			$n_{2 \text{ Eck}}$							105	210	247	137	284	
			$n_{2 \text{ th}}$							105	210	232	137	212	
14.286	642	2.79	$M_2$												122
			c												5.0
			$n_{2 \text{ Eck}}$												105
			$n_{2 \text{ th}}$												105
15.400	515	2.26	$M_2$							146	116	109	198	162	
			c							3.5	3.9	3.9	2.6	2.6	
			$n_{2 \text{ Eck}}$							97	195	229	127	263	
			$n_{2 \text{ th}}$							97	195	229	127	215	
15.400	644	2.26	$M_2$												132
			c												4.7
			$n_{2 \text{ Eck}}$												97
			$n_{2 \text{ th}}$												97
17.500	585	2.21	$M_2$							166	132	124	226	184	
			c							3.5	3.9	3.9	2.6	2.6	
			$n_{2 \text{ Eck}}$							86	171	201	111	231	
			$n_{2 \text{ th}}$							86	171	201	111	189	
17.500	680	2.21	$M_2$												151
			c												4.4
			$n_{2 \text{ Eck}}$												86
			$n_{2 \text{ th}}$												86
20.044	418	1.38	$M_2$		57	71	85								
			c		5.8	4.6	3.9								
			$n_{2 \text{ Eck}}$		187	202	202								
			$n_{2 \text{ th}}$		187	202	202								
20.044	538	1.38	$M_2$					103	80	191	152	143	260	212	
			c					5.0	5.3	2.8	3.1	3.2	2.1	2.1	
			$n_{2 \text{ Eck}}$					97	202	75	150	176	97	202	
			$n_{2 \text{ th}}$					97	202	75	150	176	97	193	
20.044	694	1.38	$M_2$												174
			c												3.9
			$n_{2 \text{ Eck}}$												75
			$n_{2 \text{ th}}$												75
22.778	475	1.35	$M_2$		65	81	96								
			c		5.8	4.6	3.9								
			$n_{2 \text{ Eck}}$		165	178	178								
			$n_{2 \text{ th}}$		165	178	178								

$M \dots$  [Nm]  
 $n \dots$  [r/min]  
 $J \dots$  [kgcm<sup>2</sup>]

$P \dots$  [kW]  
 $I \dots$  [A]  
 $i \dots$  [-]  
 $c \dots$  [-]

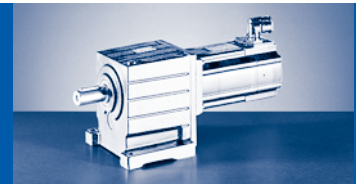

$M_{2GN} \leq 706 \text{ Nm}$

14DC36	14HC15	14HC32	14LC15	14LC32	14PC14	14PC32	19FC14	19FC30	19JC14	19JC30	19PC14	19PC30	GST07-2S			
...500	...500	...500	...500	...500	...500	...500	...500	...500	...500	...500	...500	...500	$M_1$	$J_G$	$M_{2GN}$	i
7.50	16.00	14.00	23.00	17.20	30.00	21.00	27.00	21.00	40.00	29.00	51.00	32.00	$n_1$			
3600	1500	3225	1500	3225	1350	3225	1425	3000	1425	3000	1350	3000	$I_{M230}$			
													$I_{M400}$			
7.5	6.6	11.9	9.7	15.0	10.8	15.6	8.6	14.0	12.3	18.5	14.3	19.0	$P_N$			
2.80	2.50	4.70	3.60	5.80	4.20	7.10	4.00	6.60	6.00	9.10	7.20	10.00	$J_M$			
8.22	14.32	14.32	23.44	23.44	34.74	34.82	65.12	65.04	105.04	105.12	160.12	160.04	$M_2$			
													c	2.86	489	12.571
													$n_2$			
													$n_2$			
													$n_2$			
													$M_2$			
88	191	168	277	207	363	254							c	2.86	601	12.571
4.9	3.1	2.7	2.1	2.2	1.6	1.8							$n_2$			
286	119	257	119	257	107	257							$n_2$			
273	119	243	119	233	107	216							$n_2$			
													$M_2$			
													c	2.79	432	14.286
													$n_2$			
													$n_2$			
													$M_2$			
													c	2.79	556	14.286
													$n_2$			
													$n_2$			
100	217	191	315	236	413	289							$M_2$			
4.6	2.9	2.6	2.0	2.1	1.5	1.7							c	2.79	642	14.286
252	105	226	105	226	95	226							$n_2$			
238	105	211	105	202	95	183							$n_2$			
													$M_2$			
													c	2.26	515	15.400
													$n_2$			
													$n_2$			
108	235	205	341	254	446	311							$M_2$			
4.9	2.7	2.7	1.9	2.2	1.4	1.8							c	2.26	644	15.400
234	97	209	97	209	88	209							$n_2$			
233	97	209	97	209	88	195							$n_2$			
													$M_2$			
													c	2.21	585	17.500
													$n_2$			
													$n_2$			
123	267	234	388	289	508	354							$M_2$			
4.5	2.5	2.5	1.7	2.1	1.3	1.7							c	2.21	680	17.500
206	86	184	86	184	77	184							$n_2$			
205	86	184	86	181	77	165							$n_2$			
													$M_2$			
													c	1.38	418	20.044
													$n_2$			
													$n_2$			
													$M_2$			
													c	1.38	538	20.044
													$n_2$			
													$n_2$			
141	307	269	445	332	582	406							$M_2$			
4.0	2.2	2.2	1.6	1.8	1.2	1.5							c	1.38	694	20.044
180	75	161	75	161	67	161							$n_2$			
179	75	161	75	161	67	161							$n_2$			
													$M_2$			
													c	1.35	475	22.778
													$n_2$			
													$n_2$			

M ... [Nm]  
n ... [r/min]  
J ... [kgcm<sup>2</sup>]

P ... [kW]  
I ... [A]  
i [-]  
c [-]

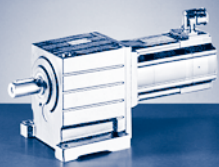

# GST [Nm]

## GST□□-□S (MCS)

$M_{2GN} \leq 706 \text{ Nm}$

GST07-2S				09DC41	09FC38	09HC41	09LC41	12DC20	12DC41	12HC15	12HC30	12HC35	12LC20	12LC41	14DC15
				...S00	...S00	...S00	...S00	...S00	...S00	...S00	...S00	...S00	...S00	...S00	...S00
i	$M_{2GN}$	$J_G$	$M_1$	2.30	3.10	3.80	4.50	5.50	4.30	10.00	8.00	7.50	13.50	11.00	9.20
			$n_1$	4050	3750	4050	4050	1950	4050	1500	3000	3525	1950	4050	1500
			$I_{M230}$	4.6	5.0	6.8	8.4	5.2	8.8	7.6	10.5		11.8		
			$I_{M400}$	2.3	2.5	3.4	4.2	2.6	4.5	3.8		5.7	5.9	10.2	4.5
			$P_N$	1.00	1.20	1.60	1.90	1.10	1.80	1.60	2.50	2.80	2.80	4.70	1.45
			$J_M$	1.13	1.53	1.93	2.83	4.12	4.12	7.42	7.42	7.42	10.72	10.72	8.22
22.778	611	1.35	$M_2$					117	91	217	173	162	295	240	
			c				5.0	5.3	2.8	3.1	3.2	2.1	2.1		
			$n_{2 \text{ Eck}}$				86	178	66	132	155	86	178		
			$n_{2 \text{ th}}$				86	178	66	132	155	86	170		
22.778	682	1.35	$M_2$												198
			c												3.4
			$n_{2 \text{ Eck}}$												66
			$n_{2 \text{ th}}$												66
24.567	438	1.02	$M_2$		71	88	105								
			c		5.0	4.0	3.3								
			$n_{2 \text{ Eck}}$		153	165	165								
			$n_{2 \text{ th}}$		153	165	165								
24.567	564	1.02	$M_2$					127	99	235	187	176	319	260	
			c					4.3	4.5	2.4	2.7	2.7	1.8	1.8	
			$n_{2 \text{ Eck}}$					79	165	61	122	144	79	165	
			$n_{2 \text{ th}}$					79	165	61	122	143	79	165	
24.567	706	1.02	$M_2$												214
			c												3.2
			$n_{2 \text{ Eck}}$												61
			$n_{2 \text{ th}}$												61
27.917	498	1.01	$M_2$		81	100	119								
			c		5.0	4.0	3.3								
			$n_{2 \text{ Eck}}$		134	145	145								
			$n_{2 \text{ th}}$		134	145	145								
27.917	641	1.01	$M_2$					144	112	267	213	200	363	296	
			c					4.3	4.5	2.4	2.7	2.7	1.8	1.8	
			$n_{2 \text{ Eck}}$					70	145	54	108	126	70	145	
			$n_{2 \text{ th}}$					70	145	54	107	126	70	145	
27.917	691	1.01	$M_2$												245
			c												2.8
			$n_{2 \text{ Eck}}$												54
			$n_{2 \text{ th}}$												54
32.267	450	0.66	$M_2$	69	94	116	139								
			c	5.1	3.9	3.1	2.6								
			$n_{2 \text{ Eck}}$	126	116	126	126								
			$n_{2 \text{ th}}$	126	116	126	126								
32.267	580	0.66	$M_2$					168	131	310	248	232	421	343	
			c					3.4	3.5	1.9	2.1	2.1	1.4	1.4	
			$n_{2 \text{ Eck}}$					60	126	47	93	109	60	126	
			$n_{2 \text{ th}}$					60	126	46	93	109	60	126	
36.667	512	0.65	$M_2$	78	107	132	157								
			c	5.1	3.9	3.1	2.6								
			$n_{2 \text{ Eck}}$	111	102	111	111								
			$n_{2 \text{ th}}$	110	102	110	110								
36.667	659	0.65	$M_2$					191	149	353	281	264	478	390	
			c					3.4	3.5	1.9	2.1	2.1	1.4	1.4	
			$n_{2 \text{ Eck}}$					53	111	41	82	96	53	111	
			$n_{2 \text{ th}}$					53	110	41	82	96	53	110	
39.160	456	0.49	$M_2$	84	115	142	169								
			c	4.3	3.2	2.6	2.2								
			$n_{2 \text{ Eck}}$	103	96	103	103								
			$n_{2 \text{ th}}$	103	96	103	103								

M ... [Nm]  
 n ... [r/min]  
 J ... [kgcm<sup>2</sup>]

P ... [kW]  
 I ... [A]  
 i [-]  
 c [-]

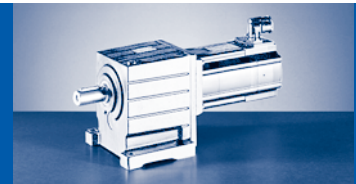

$M_{2GN} \leq 706 \text{ Nm}$

14DC36	14HC15	14HC32	14LC15	14LC32	14PC14	14PC32	19FC14	19FC30	19JC14	19JC30	19PC14	19PC30	GST07-2S			
...500	...500	...500	...500	...500	...500	...500	...500	...500	...500	...500	...500	...500	$M_1$	$J_G$	$M_{2GN}$	i
7.50	16.00	14.00	23.00	17.20	30.00	21.00	27.00	21.00	40.00	29.00	51.00	32.00	$n_1$			
3600	1500	3225	1500	3225	1350	3225	1425	3000	1425	3000	1350	3000	$I_{M230}$			
7.5	6.6	11.9	9.7	15.0	10.8	15.6	8.6	14.0	12.3	18.5	14.3	19.0	$I_{M400}$			
2.80	2.50	4.70	3.60	5.80	4.20	7.10	4.00	6.60	6.00	9.10	7.20	10.00	$P_N$			
8.22	14.32	14.32	23.44	23.44	34.74	34.82	65.12	65.04	105.04	105.12	160.12	160.04	$J_M$			
													$M_2$ c	1.35	611	22.778
													$n_2$ Eck			
													$n_2$ th			
161	350	306	506	378	663	463							$M_2$ c	1.35	682	22.778
3.5	1.9	1.9	1.3	1.6	1.0	1.3							$n_2$ Eck			
158	66	142	66	142	59	142							$n_2$ th			
158	66	142	66	142	59	135							$M_2$ c	1.02	438	24.567
													$n_2$ Eck			
													$n_2$ th			
													$M_2$ c	1.02	564	24.567
													$n_2$ Eck			
													$n_2$ th			
174	378	331	547	408		499							$M_2$ c	1.02	706	24.567
3.4	1.9	1.9	1.3	1.5		1.2							$n_2$ Eck			
147	61	131	61	131		131							$n_2$ th			
146	61	131	61	131		131							$M_2$ c	1.01	498	27.917
													$n_2$ Eck			
													$n_2$ th			
													$M_2$ c	1.01	641	27.917
													$n_2$ Eck			
													$n_2$ th			
199	431	377	622	464		568							$M_2$ c	1.01	691	27.917
2.9	1.6	1.6	1.1	1.3		1.1							$n_2$ Eck			
129	54	116	54	116		116							$n_2$ th			
129	54	116	54	116		116							$M_2$ c	0.66	450	32.267
													$n_2$ Eck			
													$n_2$ th			
													$M_2$ c	0.66	580	32.267
													$n_2$ Eck			
													$n_2$ th			
													$M_2$ c	0.65	512	36.667
													$n_2$ Eck			
													$n_2$ th			
													$M_2$ c	0.65	659	36.667
													$n_2$ Eck			
													$n_2$ th			
													$M_2$ c	0.49	456	39.160
													$n_2$ Eck			
													$n_2$ th			

M ... [Nm]  
n ... [r/min]  
J ... [kgcm<sup>2</sup>]

P ... [kW]  
I ... [A]  
i [-]  
c [-]

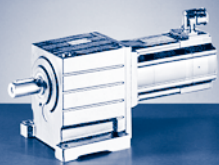

# GST [Nm]

## GST□□-□S (MCS)

$M_{2GN} \leq 706 \text{ Nm}$

GST07-2S				09DC41	09FC38	09HC41	09LC41	12DC20	12DC41	12HC15	12HC30	12HC35	12LC20	12LC41	14DC15	
				...S00	...S00	...S00	...S00	...S00	...S00	...S00	...S00	...S00	...S00	...S00	...S00	
i	$M_{2GN}$	$J_G$	$M_1$	2.30	3.10	3.80	4.50	5.50	4.30	10.00	8.00	7.50	13.50	11.00	9.20	
			$n_1$	4050	3750	4050	4050	1950	4050	1500	3000	3525	1950	4050	1500	
			$I_{M230}$	4.6	5.0	6.8	8.4	5.2	8.8	7.6	10.5		11.8			
			$I_{M400}$	2.3	2.5	3.4	4.2	2.6	4.5	3.8		5.7	5.9	10.2	4.5	
			$P_N$	1.00	1.20	1.60	1.90	1.10	1.80	1.60	2.50	2.80	2.80	4.70	1.45	
			$J_M$	1.13	1.53	1.93	2.83	4.12	4.12	7.42	7.42	7.42	10.72	10.72	8.22	
39.160	586	0.49	$M_2$					205	160	378	302	283	512	417		
			c					2.8	2.9	1.5	1.7	1.8	1.1	1.2		
			$n_{2 \text{ Eck}}$						50	103	38	77	90	50	103	
			$n_{2 \text{ th}}$						50	103	38	77	90	50	103	
44.500	518	0.48	$M_2$	95	130	161	191									
			c	4.7	3.6	2.9	2.4									
			$n_{2 \text{ Eck}}$	91	84	91	91									
			$n_{2 \text{ th}}$	91	84	91	91									
44.500	666	0.48	$M_2$					233	181	429	342	321	582	474		
			c					2.8	3.3	1.5	1.9	2.0	1.1	1.3		
			$n_{2 \text{ Eck}}$					44	91	34	67	79	44	91		
			$n_{2 \text{ th}}$					44	91	34	67	79	44	91		
49.500	461	0.33	$M_2$	107	146	180	214									
			c	3.8	2.9	2.3	1.9									
			$n_{2 \text{ Eck}}$	82	76	82	82									
			$n_{2 \text{ th}}$	82	76	82	82									
56.250	524	0.33	$M_2$	122	166	205	243									
			c	3.8	2.9	2.3	1.9									
			$n_{2 \text{ Eck}}$	72	67	72	72									
			$n_{2 \text{ th}}$	72	67	72	72									

$M \dots$  [Nm]  
 $n \dots$  [r/min]  
 $J \dots$  [kgcm<sup>2</sup>]

$P \dots$  [kW]  
 $I \dots$  [A]  
 $i \dots$  [-]  
 $c \dots$  [-]

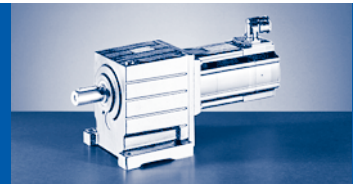

$M_{2GN} \leq 706 \text{ Nm}$

14DC36	14HC15	14HC32	14LC15	14LC32	14PC14	14PC32	19FC14	19FC30	19JC14	19JC30	19PC14	19PC30	GST07-2S			
...S00	...S00	...S00	...S00	...S00	...S00	...S00	...S00	...S00	...S00	...S00	...S00	...S00	$M_1$	$J_G$	$M_{2GN}$	i
7.50	16.00	14.00	23.00	17.20	30.00	21.00	27.00	21.00	40.00	29.00	51.00	32.00	$n_1$			
3600	1500	3225	1500	3225	1350	3225	1425	3000	1425	3000	1350	3000	$I_{M230}$			
7.5	6.6	11.9	9.7	15.0	10.8	15.6	8.6	14.0	12.3	18.5	14.3	19.0	$I_{M400}$			
2.80	2.50	4.70	3.60	5.80	4.20	7.10	4.00	6.60	6.00	9.10	7.20	10.00	$P_N$			
8.22	14.32	14.32	23.44	23.44	34.74	34.82	65.12	65.04	105.04	105.12	160.12	160.04	$J_M$			
													$M_2$ c $n_{2 \text{ Eck}}$ $n_{2 \text{ th}}$	0.49	586	39.160
													$M_2$ c $n_{2 \text{ Eck}}$ $n_{2 \text{ th}}$	0.48	518	44.500
													$M_2$ c $n_{2 \text{ Eck}}$ $n_{2 \text{ th}}$	0.48	666	44.500
													$M_2$ c $n_{2 \text{ Eck}}$ $n_{2 \text{ th}}$	0.33	461	49.500
													$M_2$ c $n_{2 \text{ Eck}}$ $n_{2 \text{ th}}$	0.33	524	56.250

M ... [Nm]  
n ... [r/min]  
J ... [kgcm<sup>2</sup>]

P ... [kW]  
I ... [A]  
i [-]  
c [-]

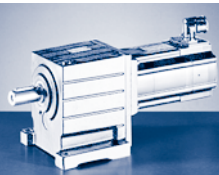

# GST [Nm]

## GST□□-□S (MCS)

$M_{2GN} \leq 710 \text{ Nm}$

GST07-3S				06CC41	06FC41	06IC41	09DC41	09FC38	09HC41	09LC41
				...500	...500	...500	...500	...500	...500	...500
i	$M_{2GN}$	$J_G$	$M_1$	0.60	1.20	1.50	2.30	3.10	3.80	4.50
			$n_1$	4050	4050	4050	4050	3750	4050	4050
			$I_{M230}$	2.6	2.9	3.2	4.6	5.0	6.8	8.4
			$I_{M400}$	1.3	1.5	1.6	2.3	2.5	3.4	4.2
			$P_N$	0.25	0.51	0.64	1.00	1.20	1.60	1.90
			$J_M$	0.17	0.25	0.33	1.13	1.53	1.93	2.83
39.200	692	0.97	$M_2$					111	138	164
			c				5.0	4.0	3.4	
			$n_{2 \text{ Eck}}$				96	103	103	
			$n_{2 \text{ th}}$				96	103	103	
44.000	706	0.53	$M_2$					125	155	185
			c				5.0	4.0	3.4	
			$n_{2 \text{ Eck}}$				85	92	92	
			$n_{2 \text{ th}}$				85	92	92	
51.022	700	0.84	$M_2$				107	146	181	215
			c				5.7	4.3	3.4	2.9
			$n_{2 \text{ Eck}}$				79	74	79	79
			$n_{2 \text{ th}}$				79	74	79	79
53.900	706	0.48	$M_2$				113	154	191	228
			c				5.4	4.1	3.3	2.8
			$n_{2 \text{ Eck}}$				75	70	75	75
			$n_{2 \text{ th}}$				75	70	75	75
65.079	587	0.31	$M_2$			89				
			c			5.7				
			$n_{2 \text{ Eck}}$			62				
			$n_{2 \text{ th}}$			62				
65.079	707	0.31	$M_2$				138	188	232	276
			c				4.5	3.4	2.7	2.3
			$n_{2 \text{ Eck}}$				62	58	62	62
			$n_{2 \text{ th}}$				62	58	62	62
70.156	706	0.43	$M_2$				149	203	251	298
			c				4.1	3.2	2.5	2.1
			$n_{2 \text{ Eck}}$				58	54	58	58
			$n_{2 \text{ th}}$				58	53	58	58
79.762	710	0.54	$M_2$			109	170	232	286	340
			c			5.6	3.7	2.8	2.2	1.9
			$n_{2 \text{ Eck}}$			51	51	47	51	51
			$n_{2 \text{ th}}$			51	51	47	51	51
85.983	706	0.40	$M_2$			118	184	251	309	367
			c			5.2	3.4	2.6	2.1	1.7
			$n_{2 \text{ Eck}}$			47	47	44	47	47
			$n_{2 \text{ th}}$			47	47	44	47	47
97.708	710	0.40	$M_2$		107	135	210	286	352	418
			c		5.7	4.6	3.0	2.3	1.8	1.5
			$n_{2 \text{ Eck}}$		42	42	42	38	42	42
			$n_{2 \text{ th}}$		41	41	41	38	41	41
111.915	706	0.24	$M_2$		123	155	242	328	404	480
			c		5.0	4.0	2.6	2.0	1.6	1.3
			$n_{2 \text{ Eck}}$		36	36	36	34	36	36
			$n_{2 \text{ th}}$		36	36	36	34	36	36
127.176	710	0.24	$M_2$		141	177	276	374	460	546
			c		4.4	3.5	2.3	1.8	1.4	1.2
			$n_{2 \text{ Eck}}$		32	32	32	30	32	32
			$n_{2 \text{ th}}$		32	32	32	29	32	32
139.211	706	0.17	$M_2$		155	195	303	410	504	598
			c		4.0	3.2	2.1	1.6	1.3	1.1
			$n_{2 \text{ Eck}}$		29	29	29	27	29	29
			$n_{2 \text{ th}}$		29	29	29	27	29	29

$M \dots$  [Nm]  
 $n \dots$  [r/min]  
 $J \dots$  [kgcm<sup>2</sup>]

$P \dots$  [kW]  
 $I \dots$  [A]  
 $i$  [-]  
 $c$  [-]

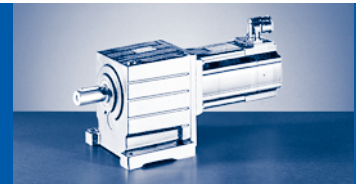

$M_{2GN} \leq 710 \text{ Nm}$

12DC20	12DC41	12HC15	12HC30	12HC35	12LC20	12LC41	GST07-3S			
...500	...500	...500	...500	...500	...500	...500				
5.50	4.30	10.00	8.00	7.50	13.50	11.00	$M_1$	$J_G$	$M_{2GN}$	$i$
1950	4050	1500	3000	3525	1950	4050	$n_1$			
5.2	8.8	7.6	10.5		11.8		$I_{M230}$			
2.6	4.5	3.8		5.7	5.9	10.2	$I_{M400}$			
1.10	1.80	1.60	2.50	2.80	2.80	4.70	$P_N$			
4.12	4.12	7.42	7.42	7.42	10.72	10.72	$J_M$			
201	157	371	296	278	504	410	$M_2$			
3.4	3.5	1.9	2.1	2.1	1.4	1.4	c	0.97	692	39.200
50	103	38	77	90	50	103	$n_{2Eck}$			
50	103	38	77	90	50	94	$n_{2th}$			
226	176	418	333	312	566	461	$M_2$			
3.1	3.5	1.7	2.1	2.1	1.2	1.4	c	0.53	706	44.000
44	92	34	68	80	44	92	$n_{2Eck}$			
44	92	34	68	80	44	92	$n_{2th}$			
264	205	485	387	363	658	535	$M_2$			
2.6	3.0	1.4	1.8	1.8	1.1	1.2	c	0.84	700	51.022
38	79	29	59	69	38	79	$n_{2Eck}$			
38	79	29	59	69	38	68	$n_{2th}$			
279	217	513	409	383	695	566	$M_2$			
2.5	2.9	1.4	1.7	1.7	1.0	1.1	c	0.48	706	53.900
36	75	28	56	65	36	75	$n_{2Eck}$			
36	75	28	56	65	36	75	$n_{2th}$			
							$M_2$			
							c	0.31	587	65.079
							$n_{2Eck}$			
							$n_{2th}$			
							$M_2$			
							c	0.31	707	65.079
							$n_{2Eck}$			
							$n_{2th}$			
365	285	670	535	501			$M_2$			
1.9	2.2	1.1	1.3	1.3			c	0.43	706	70.156
28	58	21	43	50			$n_{2Eck}$			
28	58	21	43	50			$n_{2th}$			
416	324		609	571			$M_2$			
1.7	2.0		1.2	1.2			c	0.54	710	79.762
25	51		38	44			$n_{2Eck}$			
24	51		38	44			$n_{2th}$			
449	350		657	616			$M_2$			
1.6	1.8		1.1	1.1			c	0.40	706	85.983
23	47		35	41			$n_{2Eck}$			
23	47		35	41			$n_{2th}$			
512	399						$M_2$			
1.4	1.6						c	0.40	710	97.708
20	42						$n_{2Eck}$			
20	41						$n_{2th}$			
							$M_2$			
							c	0.24	706	111.915
							$n_{2Eck}$			
							$n_{2th}$			
							$M_2$			
							c	0.24	710	127.176
							$n_{2Eck}$			
							$n_{2th}$			
							$M_2$			
							c	0.17	706	139.211
							$n_{2Eck}$			
							$n_{2th}$			

M ... [Nm]  
n ... [r/min]  
J ... [kgcm<sup>2</sup>]

P ... [kW]  
I ... [A]  
i [-]  
c [-]

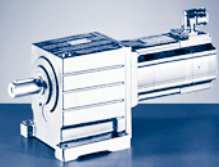

# GST [Nm]

## GST□□-□S (MCS)

$M_{2GN} \leq 710 \text{ Nm}$

GST07-3S				06CC41	06FC41	06IC41	09DC41	09FC38	09HC41	09LC41
				...500	...500	...500	...500	...500	...500	...500
i	$M_{2GN}$	$J_G$	$M_1$	0.60	1.20	1.50	2.30	3.10	3.80	4.50
			$n_1$	4050	4050	4050	4050	3750	4050	4050
			$I_{M230}$	2.6	2.9	3.2	4.6	5.0	6.8	8.4
			$I_{M400}$	1.3	1.5	1.6	2.3	2.5	3.4	4.2
			$P_N$	0.25	0.51	0.64	1.00	1.20	1.60	1.90
			$J_M$	0.17	0.25	0.33	1.13	1.53	1.93	2.83
158.194	710	0.17	$M_2$		177	222	345	467	574	
			c		3.5	2.8	1.9	1.4	1.1	
			$n_{2 \text{ Eck}}$		26	26	26	24	26	
			$n_{2 \text{ th}}$		26	26	26	24	26	
180.156	706	0.11	$M_2$		202	254				
			c		3.1	2.5				
			$n_{2 \text{ Eck}}$		23	23				
			$n_{2 \text{ th}}$		22	22				
204.722	710	0.11	$M_2$	112	231	290				
			c	5.5	2.7	2.2				
			$n_{2 \text{ Eck}}$	20	20	20				
			$n_{2 \text{ th}}$	20	20	20				
236.622	706	0.10	$M_2$	130	268	336				
			c	4.7	2.4	1.9				
			$n_{2 \text{ Eck}}$	17	17	17				
			$n_{2 \text{ th}}$	17	17	17				
248.458	710	0.08	$M_2$	137	281	353				
			c	4.5	2.3	1.8				
			$n_{2 \text{ Eck}}$	16	16	16				
			$n_{2 \text{ th}}$	16	16	16				
268.889	710	0.10	$M_2$	149	305	383				
			c	4.2	2.1	1.7				
			$n_{2 \text{ Eck}}$	15	15	15				
			$n_{2 \text{ th}}$	15	15	15				
326.333	710	0.07	$M_2$	182	371	466				
			c	3.4	1.7	1.4				
			$n_{2 \text{ Eck}}$	12	12	12				
			$n_{2 \text{ th}}$	12	12	12				

M ... [Nm]  
n ... [r/min]  
J ... [kgcm<sup>2</sup>]

P ... [kW]  
I ... [A]  
i [-]  
c [-]

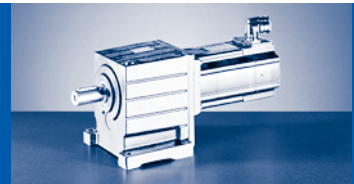

$M_{2GN} \leq 710 \text{ Nm}$

12DC20	12DC41	12HC15	12HC30	12HC35	12LC20	12LC41	GST07-3S			
...500	...500	...500	...500	...500	...500	...500	$M_1$	$J_G$	$M_{2GN}$	$i$
5.50	4.30	10.00	8.00	7.50	13.50	11.00	$n_1$			
1950	4050	1500	3000	3525	1950	4050	$I_{M230}$			
5.2	8.8	7.6	10.5		11.8		$I_{M400}$			
2.6	4.5	3.8		5.7	5.9	10.2	$P_N$			
1.10	1.80	1.60	2.50	2.80	2.80	4.70	$J_M$			
4.12	4.12	7.42	7.42	7.42	10.72	10.72	$M_2$ c $n_2$ Eck $n_2$ th	0.17	710	158.194
							$M_2$ c $n_2$ Eck $n_2$ th	0.11	706	180.156
							$M_2$ c $n_2$ Eck $n_2$ th	0.11	710	204.722
							$M_2$ c $n_2$ Eck $n_2$ th	0.10	706	236.622
							$M_2$ c $n_2$ Eck $n_2$ th	0.08	710	248.458
							$M_2$ c $n_2$ Eck $n_2$ th	0.10	710	268.889
							$M_2$ c $n_2$ Eck $n_2$ th	0.07	710	326.333

M ... [Nm]  
n ... [r/min]  
J ... [kgcm<sup>2</sup>]

P ... [kW]  
I ... [A]  
i [-]  
c [-]

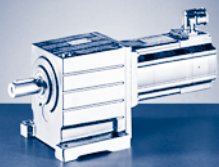

# GST [Nm]

## GST□□-□S (MCS)

$M_{2GN} \leq 357 \text{ Nm}$

GST09-1S				12DC20	12DC41	12HC15	12HC30	12HC35	12LC20	12LC41	14DC15	14DC36	14HC15
				...500	...500	...500	...500	...500	...500	...500	...500	...500	...500
i	$M_{2GN}$	$J_G$	$M_1$	5.50	4.30	10.00	8.00	7.50	13.50	11.00	9.20	7.50	16.00
			$n_1$	1950	4050	1500	3000	3525	1950	4050	1500	3600	1500
			$I_{M230}$	5.2	8.8	7.6	10.5		11.8				
			$I_{M400}$	2.6	4.5	3.8		5.7	5.9	10.2	4.5	7.5	6.6
			$P_N$	1.10	1.80	1.60	2.50	2.80	2.80	4.70	1.45	2.80	2.50
			$J_M$	4.12	4.12	7.42	7.42	7.42	10.72	10.72	8.22	8.22	14.32
1.560	277	22.20	$M_2$ c $n_{2 \text{ Eck}}$ $n_{2 \text{ th}}$										
2.048	198	15.60	$M_2$ c $n_{2 \text{ Eck}}$ $n_{2 \text{ th}}$										
2.048	308	15.60	$M_2$ c $n_{2 \text{ Eck}}$ $n_{2 \text{ th}}$										
2.333	207	12.20	$M_2$ c $n_{2 \text{ Eck}}$ $n_{2 \text{ th}}$										35 5.6 643 643
2.333	322	12.20	$M_2$ c $n_{2 \text{ Eck}}$ $n_{2 \text{ th}}$										
2.810	140	9.58	$M_2$ c $n_{2 \text{ Eck}}$ $n_{2 \text{ th}}$			27 5.0 534 534	21 5.0 1068 1012	20 5.1 1255 1014	36 3.4 694 694	30 3.3 1442 927			
2.810	218	9.58	$M_2$ c $n_{2 \text{ Eck}}$ $n_{2 \text{ th}}$										43 4.9 534 534
2.810	339	9.58	$M_2$ c $n_{2 \text{ Eck}}$ $n_{2 \text{ th}}$										
3.444	230	7.30	$M_2$ c $n_{2 \text{ Eck}}$ $n_{2 \text{ th}}$										53 4.2 436 435
3.444	357	7.30	$M_2$ c $n_{2 \text{ Eck}}$ $n_{2 \text{ th}}$										
4.667	156	4.60	$M_2$ c $n_{2 \text{ Eck}}$ $n_{2 \text{ th}}$	24 5.7 418 418	19 5.7 868 814	45 3.4 321 321	36 3.4 643 643	34 3.4 755 744	61 2.3 418 418	50 2.2 868 685			
4.667	243	4.60	$M_2$ c $n_{2 \text{ Eck}}$ $n_{2 \text{ th}}$								40 5.8 321 321	33 5.3 771 769	72 3.3 321 321
5.667	162	3.51	$M_2$ c $n_{2 \text{ Eck}}$ $n_{2 \text{ th}}$	30 4.8 344 344	23 4.9 715 715	55 2.9 265 265	44 2.9 529 529	41 2.9 622 622	75 2.0 344 344	61 1.9 715 641			

$M \dots$  [Nm]  
 $n \dots$  [r/min]  
 $J \dots$  [kgcm<sup>2</sup>]

$P \dots$  [kW]  
 $I \dots$  [A]  
 $i \dots$  [-]  
 $c \dots$  [-]

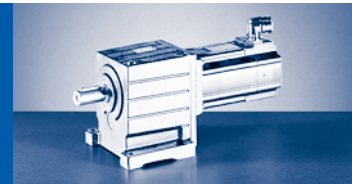

$M_{2GN} \leq 357 \text{ Nm}$

14HC32	14LC15	14LC32	14PC14	14PC32	19FC14	19FC30	19JC14	19JC30	19PC14	19PC30	GST09-1S			
...500	...500	...500	...500	...500	...500	...500	...500	...500	...500	...500	$M_1$	$J_G$	$M_{2GN}$	i
14.00	23.00	17.20	30.00	21.00	27.00	21.00	40.00	29.00	51.00	32.00	$n_1$			
3225	1500	3225	1350	3225	1425	3000	1425	3000	1350	3000	$I_{M230}$			
11.9	9.7	15.0	10.8	15.6	8.6	14.0	12.3	18.5	14.3	19.0	$I_{M400}$			
4.70	3.60	5.80	4.20	7.10	4.00	6.60	6.00	9.10	7.20	10.00	$P_N$			
14.32	23.44	23.44	34.74	34.82	65.12	65.04	105.04	105.12	160.12	160.04	$J_M$			
							59	43	76	47	$M_2$			
							4.5	4.9	3.5	4.5	c	22.20	277	1.560
							914	1923	865	1923	$n_{2 \text{ Eck}}$			
							913	1294	865	1267	$n_{2 \text{ th}}$			
27	45	33	59	41							$M_2$			
5.4	4.3	4.4	3.3	3.6							c	15.60	198	2.048
1575	733	1575	659	1575							$n_{2 \text{ Eck}}$			
1142	733	1094	659	1048							$n_{2 \text{ th}}$			
					52	40	78	57	101	63	$M_2$			
					5.7	5.8	3.8	4.2	3.0	3.8	c	15.60	308	2.048
					696	1465	696	1465	659	1465	$n_{2 \text{ Eck}}$			
					696	1080	696	1080	659	1058	$n_{2 \text{ th}}$			
31	51	38	68	47							$M_2$			
5.0	3.9	4.1	3.0	3.3							c	12.20	207	2.333
1382	643	1382	579	1382							$n_{2 \text{ Eck}}$			
1077	643	1032	579	988							$n_{2 \text{ th}}$			
					59	46	90	65	115	72	$M_2$			
					5.2	5.3	3.5	3.8	2.7	3.5	c	12.20	322	2.333
					611	1286	611	1286	579	1286	$n_{2 \text{ Eck}}$			
					611	947	611	947	579	947	$n_{2 \text{ th}}$			
											$M_2$			
											c	9.58	140	2.810
											$n_{2 \text{ Eck}}$			
											$n_{2 \text{ th}}$			
37	62	46	82	57							$M_2$			
4.4	3.4	3.6	2.6	2.9							c	9.58	218	2.810
1148	534	1148	481	1148							$n_{2 \text{ Eck}}$			
984	534	943	481	902							$n_{2 \text{ th}}$			
					72	56	108	78	139	87	$M_2$			
					4.5	4.6	3.1	3.4	2.4	3.0	c	9.58	339	2.810
					507	1068	507	1068	481	1068	$n_{2 \text{ Eck}}$			
					507	787	507	787	481	787	$n_{2 \text{ th}}$			
46	76	57	100	70							$M_2$			
3.8	3.0	3.1	2.3	2.5							c	7.30	230	3.444
936	436	936	392	936							$n_{2 \text{ Eck}}$			
845	435	811	392	778							$n_{2 \text{ th}}$			
					89	69	133	97	171	107	$M_2$			
					3.9	4.0	2.6	2.9	2.1	2.6	c	7.30	357	3.444
					414	871	414	871	392	871	$n_{2 \text{ Eck}}$			
					414	642	414	642	392	642	$n_{2 \text{ th}}$			
											$M_2$			
											c	4.60	156	4.667
											$n_{2 \text{ Eck}}$			
											$n_{2 \text{ th}}$			
63	104	78	137	96							$M_2$			
2.9	2.3	2.4	1.8	2.0							c	4.60	243	4.667
691	321	691	289	691							$n_{2 \text{ Eck}}$			
691	321	691	289	666							$n_{2 \text{ th}}$			
											$M_2$			
											c	3.51	162	5.667
											$n_{2 \text{ Eck}}$			
											$n_{2 \text{ th}}$			

$M \dots$  [Nm]  
 $n \dots$  [r/min]  
 $J \dots$  [kgcm<sup>2</sup>]

$P \dots$  [kW]  
 $I \dots$  [A]  
 $i [-]$   
 $c [-]$

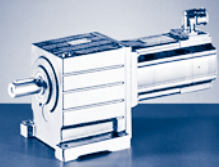

# GST [Nm]

## GST□□-□S (MCS)

$M_{2GN} \leq 357 \text{ Nm}$

GST09-1S				12DC20	12DC41	12HC15	12HC30	12HC35	12LC20	12LC41	14DC15	14DC36	14HC15	
				...500	...500	...500	...500	...500	...500	...500	...500	...500	...500	
i	$M_{2GN}$	$J_G$	$M_1$	5.50	4.30	10.00	8.00	7.50	13.50	11.00	9.20	7.50	16.00	
			$n_1$	1950	4050	1500	3000	3525	1950	4050	1500	3600	1500	
			$I_{M230}$	5.2	8.8	7.6	10.5		11.8					
			$I_{M400}$	2.6	4.5	3.8		5.7	5.9	10.2	4.5	7.5	6.6	
			$P_N$	1.10	1.80	1.60	2.50	2.80	2.80	4.70	1.45	2.80	2.50	
			$J_M$	4.12	4.12	7.42	7.42	7.42	10.72	10.72	8.22	8.22	14.32	
5.667	253	3.51	$M_2$								49	40	88	
			c									4.9	4.5	2.8
			$n_{2 \text{ Eck}}$									265	635	265
			$n_{2 \text{ th}}$									265	634	265
7.333	168	2.26	$M_2$	39	30	71	57	53	97	79				
			c	3.9	3.9	2.3	2.3	2.3	1.6	1.5				
			$n_{2 \text{ Eck}}$	266	552	205	409	481	266	552				
			$n_{2 \text{ th}}$	266	552	205	409	481	266	514				
7.333	262	2.26	$M_2$								64	53	114	
			c									4.0	3.6	2.3
			$n_{2 \text{ Eck}}$									205	491	205
			$n_{2 \text{ th}}$									205	490	205
8.900	170	1.66	$M_2$	47	37	87	69	65	118	96				
			c	3.2	3.3	1.9	1.9	2.0	1.3	1.3				
			$n_{2 \text{ Eck}}$	219	455	169	337	396	219	455				
			$n_{2 \text{ th}}$	219	455	169	337	396	219	450				
8.900	265	1.66	$M_2$								79	64	139	
			c									3.3	3.0	1.9
			$n_{2 \text{ Eck}}$									169	405	169
			$n_{2 \text{ th}}$									169	403	169
11.250	173	1.11	$M_2$	60	47	110	88	83	150	122				
			c	2.6	2.6	1.6	1.6	1.6	1.1	1.0				
			$n_{2 \text{ Eck}}$	173	360	133	267	313	173	360				
			$n_{2 \text{ th}}$	173	360	133	267	313	173	360				

$M \dots$  [Nm]  
 $n \dots$  [r/min]  
 $J \dots$  [kgcm<sup>2</sup>]

$P \dots$  [kW]  
 $I \dots$  [A]  
 $i \dots$  [-]  
 $c \dots$  [-]

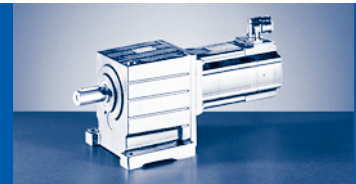

$M_{2GN} \leq 357 \text{ Nm}$

14HC32	14LC15	14LC32	14PC14	14PC32	19FC14	19FC30	19JC14	19JC30	19PC14	19PC30	GST09-1S			
...500	...500	...500	...500	...500	...500	...500	...500	...500	...500	...500	$M_1$	$J_G$	$M_{2GN}$	i
14.00	23.00	17.20	30.00	21.00	27.00	21.00	40.00	29.00	51.00	32.00	$n_1$			
3225	1500	3225	1350	3225	1425	3000	1425	3000	1350	3000	$I_{M230}$			
11.9	9.7	15.0	10.8	15.6	8.6	14.0	12.3	18.5	14.3	19.0	$I_{M400}$			
4.70	3.60	5.80	4.20	7.10	4.00	6.60	6.00	9.10	7.20	10.00	$P_N$			
14.32	23.44	23.44	34.74	34.82	65.12	65.04	105.04	105.12	160.12	160.04	$J_M$			
77	127	95	167	116							$M_2$			
2.5	2.0	2.0	1.5	1.7							c	3.51	253	5.667
569	265	569	238	569							$n_{2 \text{ Eck}}$			
569	265	569	238	569							$n_{2 \text{ th}}$			
											$M_2$			
											c	2.26	168	7.333
											$n_{2 \text{ Eck}}$			
											$n_{2 \text{ th}}$			
100	165	123	216	151							$M_2$			
2.0	1.6	1.6	1.2	1.3							c	2.26	262	7.333
440	205	440	184	440							$n_{2 \text{ Eck}}$			
440	205	440	184	440							$n_{2 \text{ th}}$			
											$M_2$			
											c	1.66	170	8.900
											$n_{2 \text{ Eck}}$			
											$n_{2 \text{ th}}$			
122	201	150	263	184							$M_2$			
1.7	1.3	1.4	1.0	1.1							c	1.66	265	8.900
362	169	362	152	362							$n_{2 \text{ Eck}}$			
362	169	362	152	362							$n_{2 \text{ th}}$			
											$M_2$			
											c	1.11	173	11.250
											$n_{2 \text{ Eck}}$			
											$n_{2 \text{ th}}$			

M ... [Nm]  
n ... [r/min]  
J ... [kgcm<sup>2</sup>]

P ... [kW]  
I ... [A]  
i [-]  
c [-]

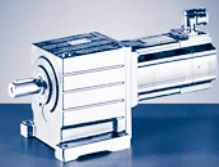

# GST [Nm]

## GST□□-□S (MCS)

$M_{2GN} \leq 1373 \text{ Nm}$

GST09-2S				12DC20	12DC41	12HC15	12HC30	12HC35	12LC20	12LC41	14DC15	14DC36	14HC15
				...500	...500	...500	...500	...500	...500	...500	...500	...500	...500
i	$M_{2GN}$	$J_G$	$M_1$	5.50	4.30	10.00	8.00	7.50	13.50	11.00	9.20	7.50	16.00
			$n_1$	1950	4050	1500	3000	3525	1950	4050	1500	3600	1500
			$I_{M230}$	5.2	8.8	7.6	10.5		11.8				
			$I_{M400}$	2.6	4.5	3.8		5.7	5.9	10.2	4.5	7.5	6.6
			$P_N$	1.10	1.80	1.60	2.50	2.80	2.80	4.70	1.45	2.80	2.50
			$J_M$	4.12	4.12	7.42	7.42	7.42	10.72	10.72	8.22	8.22	14.32
4.056	714	27.00	$M_2$ c $n_{2 \text{ Eck}}$ $n_{2 \text{ th}}$										
4.457	784	25.90	$M_2$ c $n_{2 \text{ Eck}}$ $n_{2 \text{ th}}$										
5.324	508	18.10	$M_2$ c $n_{2 \text{ Eck}}$ $n_{2 \text{ th}}$										
5.324	789	18.10	$M_2$ c $n_{2 \text{ Eck}}$ $n_{2 \text{ th}}$										
5.850	558	17.50	$M_2$ c $n_{2 \text{ Eck}}$ $n_{2 \text{ th}}$										
5.850	867	17.50	$M_2$ c $n_{2 \text{ Eck}}$ $n_{2 \text{ th}}$										
6.667	583	14.20	$M_2$ c $n_{2 \text{ Eck}}$ $n_{2 \text{ th}}$										99 5.6 225 225
6.667	905	14.20	$M_2$ c $n_{2 \text{ Eck}}$ $n_{2 \text{ th}}$										
7.305	357	11.30	$M_2$ c $n_{2 \text{ Eck}}$ $n_{2 \text{ th}}$			68 5.0 205 205	54 5.0 411 389	51 5.1 483 390	93 3.4 267 267	76 3.3 554 357			
7.305	559	11.30	$M_2$ c $n_{2 \text{ Eck}}$ $n_{2 \text{ th}}$										109 4.9 205 205
7.305	869	11.30	$M_2$ c $n_{2 \text{ Eck}}$ $n_{2 \text{ th}}$										
8.027	393	11.00	$M_2$ c $n_{2 \text{ Eck}}$ $n_{2 \text{ th}}$			75 5.0 187 187	60 5.0 374 354	56 5.1 439 355	103 3.4 243 243	84 3.3 505 324			
8.027	615	11.00	$M_2$ c $n_{2 \text{ Eck}}$ $n_{2 \text{ th}}$										120 4.9 187 187

$M \dots$  [Nm]  
 $n \dots$  [r/min]  
 $J \dots$  [kgcm<sup>2</sup>]

$P \dots$  [kW]  
 $I \dots$  [A]  
 $i \dots$  [-]  
 $c \dots$  [-]

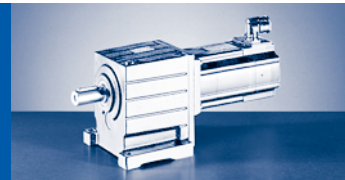

$M_{2GN} \leq 1373 \text{ Nm}$

14HC32	14LC15	14LC32	14PC14	14PC32	19FC14	19FC30	19JC14	19JC30	19PC14	19PC30	GST09-2S			
...500	...500	...500	...500	...500	...500	...500	...500	...500	...500	...500	$M_1$	$J_G$	$M_{2GN}$	i
14.00	23.00	17.20	30.00	21.00	27.00	21.00	40.00	29.00	51.00	32.00	$n_1$			
3225	1500	3225	1350	3225	1425	3000	1425	3000	1350	3000	$I_{M230}$			
11.9	9.7	15.0	10.8	15.6	8.6	14.0	12.3	18.5	14.3	19.0	$I_{M400}$			
4.70	3.60	5.80	4.20	7.10	4.00	6.60	6.00	9.10	7.20	10.00	$P_N$			
14.32	23.44	23.44	34.74	34.82	65.12	65.04	105.04	105.12	160.12	160.04	$J_M$			
							152	109	195	121	$M_2$			
							4.5	5.0	3.6	4.5	c	27.00	714	4.056
							351	740	333	740	$n_2$ Eck			
							351	498	333	488	$n_2$ th			
							167	120	215	133	$M_2$			
							4.5	5.0	3.6	4.5	c	25.90	784	4.457
							320	673	303	673	$n_2$ Eck			
							320	454	303	444	$n_2$ th			
69	115	86	151	106							$M_2$			
5.4	4.3	4.4	3.3	3.6							c	18.10	508	5.324
606	282	606	254	606							$n_2$ Eck			
439	282	421	254	403							$n_2$ th			
					133	103	201	145	258	161	$M_2$			
					5.7	5.8	3.8	4.2	3.0	3.8	c	18.10	789	5.324
					268	564	268	564	254	564	$n_2$ Eck			
					268	415	268	415	254	407	$n_2$ th			
76	126	94	166	116							$M_2$			
5.4	4.3	4.4	3.3	3.6							c	17.50	558	5.850
551	256	551	231	551							$n_2$ Eck			
400	256	383	231	367							$n_2$ th			
					146	113	220	159	284	176	$M_2$			
					5.7	5.8	3.8	4.2	3.0	3.8	c	17.50	867	5.850
					244	513	244	513	231	513	$n_2$ Eck			
					244	378	244	378	231	370	$n_2$ th			
87	144	108	190	133							$M_2$			
5.0	3.9	4.1	3.0	3.3							c	14.20	583	6.667
484	225	484	203	484							$n_2$ Eck			
377	225	361	203	346							$n_2$ th			
					167	130	252	182	324	202	$M_2$			
					5.2	5.3	3.5	3.8	2.7	3.5	c	14.20	905	6.667
					214	450	214	450	203	450	$n_2$ Eck			
					214	332	214	332	203	332	$n_2$ th			
											$M_2$			
											c	11.30	357	7.305
											$n_2$ Eck			
											$n_2$ th			
96	159	119	209	146							$M_2$			
4.4	3.4	3.6	2.6	2.9							c	11.30	559	7.305
442	205	442	185	442							$n_2$ Eck			
379	205	363	185	347							$n_2$ th			
					184	143	277	201	356	222	$M_2$			
					4.5	4.6	3.1	3.4	2.4	3.0	c	11.30	869	7.305
					195	411	195	411	185	411	$n_2$ Eck			
					195	303	195	303	185	303	$n_2$ th			
											$M_2$			
											c	11.00	393	8.027
											$n_2$ Eck			
											$n_2$ th			
105	175	130	230	160							$M_2$			
4.4	3.4	3.6	2.6	2.9							c	11.00	615	8.027
402	187	402	168	402							$n_2$ Eck			
345	187	330	168	316							$n_2$ th			

M ... [Nm]  
n ... [r/min]  
J ... [kgcm<sup>2</sup>]

P ... [kW]  
I ... [A]  
i [-]  
c [-]

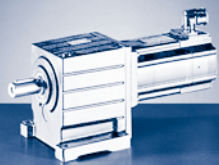

# GST [Nm]

## GST□□-□S (MCS)

$M_{2GN} \leq 1373 \text{ Nm}$

GST09-2S				12DC20	12DC41	12HC15	12HC30	12HC35	12LC20	12LC41	14DC15	14DC36	14HC15
				...500	...500	...500	...500	...500	...500	...500	...500	...500	...500
i	$M_{2GN}$	$J_G$	$M_1$	5.50	4.30	10.00	8.00	7.50	13.50	11.00	9.20	7.50	16.00
			$n_1$	1950	4050	1500	3000	3525	1950	4050	1500	3600	1500
			$I_{M230}$	5.2	8.8	7.6	10.5		11.8				
			$I_{M400}$	2.6	4.5	3.8		5.7	5.9	10.2	4.5	7.5	6.6
			$P_N$	1.10	1.80	1.60	2.50	2.80	2.80	4.70	1.45	2.80	2.50
			$J_M$	4.12	4.12	7.42	7.42	7.42	10.72	10.72	8.22	8.22	14.32
8.027	955	11.00	$M_2$ c $n_{2 \text{ Eck}}$ $n_{2 \text{ th}}$										
9.010	860	15.20	$M_2$ c $n_{2 \text{ Eck}}$ $n_{2 \text{ th}}$										
9.010	1128	15.20	$M_2$ c $n_{2 \text{ Eck}}$ $n_{2 \text{ th}}$										
10.267	897	12.40	$M_2$ c $n_{2 \text{ Eck}}$ $n_{2 \text{ th}}$										152 5.6 146 146
10.267	1178	12.40	$M_2$ c $n_{2 \text{ Eck}}$ $n_{2 \text{ th}}$										
11.667	1019	12.10	$M_2$ c $n_{2 \text{ Eck}}$ $n_{2 \text{ th}}$										172 5.6 129 129
11.667	1206	12.10	$M_2$ c $n_{2 \text{ Eck}}$ $n_{2 \text{ th}}$										
12.362	605	9.79	$M_2$ c $n_{2 \text{ Eck}}$ $n_{2 \text{ th}}$			115 5.0 121 121	92 5.0 243 230	86 5.1 285 230	158 3.4 158 158	129 3.3 328 211			
12.362	947	9.79	$M_2$ c $n_{2 \text{ Eck}}$ $n_{2 \text{ th}}$										184 4.9 121 121
12.362	1253	9.79	$M_2$ c $n_{2 \text{ Eck}}$ $n_{2 \text{ th}}$										
14.048	687	9.53	$M_2$ c $n_{2 \text{ Eck}}$ $n_{2 \text{ th}}$			131 5.0 107 107	105 5.0 214 202	98 5.1 251 203	179 3.4 139 139	146 3.3 288 185			
14.048	1076	9.53	$M_2$ c $n_{2 \text{ Eck}}$ $n_{2 \text{ th}}$										209 4.9 107 107
14.048	1283	9.53	$M_2$ c $n_{2 \text{ Eck}}$ $n_{2 \text{ th}}$										

M ... [Nm]  
n ... [r/min]  
J ... [kgcm<sup>2</sup>]

P ... [kW]  
I ... [A]  
i [-]  
c [-]

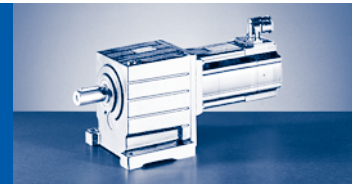

$M_{2GN} \leq 1373 \text{ Nm}$

14HC32	14LC15	14LC32	14PC14	14PC32	19FC14	19FC30	19JC14	19JC30	19PC14	19PC30	GST09-2S			
...500	...500	...500	...500	...500	...500	...500	...500	...500	...500	...500	$M_1$	$J_G$	$M_{2GN}$	i
14.00	23.00	17.20	30.00	21.00	27.00	21.00	40.00	29.00	51.00	32.00	$n_1$			
3225	1500	3225	1350	3225	1425	3000	1425	3000	1350	3000	$I_{M230}$			
11.9	9.7	15.0	10.8	15.6	8.6	14.0	12.3	18.5	14.3	19.0	$I_{M400}$			
4.70	3.60	5.80	4.20	7.10	4.00	6.60	6.00	9.10	7.20	10.00	$P_N$			
14.32	23.44	23.44	34.74	34.82	65.12	65.04	105.04	105.12	160.12	160.04	$J_M$			
					203	157	305	220	391	244	$M_2$			
					4.5	4.6	3.1	3.4	2.4	3.0	c	11.00	955	8.027
					178	374	178	374	168	374	$n_2 \text{ Eck}$			
					178	275	178	275	168	275	$n_2 \text{ th}$			
117	194	145	256	179							$M_2$			
5.4	4.3	4.4	3.3	3.6							c	15.20	860	9.010
358	167	358	150	358							$n_2 \text{ Eck}$			
259	166	249	150	238							$n_2 \text{ th}$			
					227	176	342	247	439	273	$M_2$			
					4.8	4.9	3.2	3.5	2.5	3.2	c	15.20	1128	9.010
					158	333	158	333	150	333	$n_2 \text{ Eck}$			
					158	245	158	237	150	232	$n_2 \text{ th}$			
134	222	166	293	204							$M_2$			
5.0	3.9	4.1	3.0	3.3							c	12.40	897	10.267
314	146	314	132	314							$n_2 \text{ Eck}$			
245	146	235	131	225							$n_2 \text{ th}$			
					260	202	390	282	501	312	$M_2$			
					4.4	4.5	3.0	3.2	2.3	2.9	c	12.40	1178	10.267
					139	292	139	292	132	292	$n_2 \text{ Eck}$			
					139	215	139	215	131	215	$n_2 \text{ th}$			
152	253	189	333	232							$M_2$			
5.0	3.9	4.1	3.0	3.3							c	12.10	1019	11.667
276	129	276	116	276							$n_2 \text{ Eck}$			
215	129	206	116	198							$n_2 \text{ th}$			
					296	230	445	322	571	356	$M_2$			
					4.0	4.0	2.7	2.9	2.1	2.6	c	12.10	1206	11.667
					122	257	122	257	116	257	$n_2 \text{ Eck}$			
					122	189	122	189	116	188	$n_2 \text{ th}$			
											$M_2$			
											c	9.79	605	12.362
											$n_2 \text{ Eck}$			
											$n_2 \text{ th}$			
162	269	201	354	247							$M_2$			
4.4	3.4	3.6	2.6	2.9							c	9.79	947	12.362
261	121	261	109	261							$n_2 \text{ Eck}$			
224	121	214	109	205							$n_2 \text{ th}$			
					314	244	472	341	605	378	$M_2$			
					3.9	4.0	2.6	2.9	2.1	2.6	c	9.79	1253	12.362
					115	243	115	243	109	243	$n_2 \text{ Eck}$			
					115	179	115	179	109	179	$n_2 \text{ th}$			
											$M_2$			
											c	9.53	687	14.048
											$n_2 \text{ Eck}$			
											$n_2 \text{ th}$			
184	306	228	402	281							$M_2$			
4.4	3.4	3.6	2.6	2.9							c	9.53	1076	14.048
230	107	230	96	230							$n_2 \text{ Eck}$			
197	107	189	96	180							$n_2 \text{ th}$			
					359	279	538	389	689	430	$M_2$			
					3.5	3.6	2.4	2.6	1.9	2.3	c	9.53	1283	14.048
					101	214	101	214	96	214	$n_2 \text{ Eck}$			
					101	157	101	157	96	157	$n_2 \text{ th}$			

$M \dots$  [Nm]  
 $n \dots$  [r/min]  
 $J \dots$  [kgcm<sup>2</sup>]

$P \dots$  [kW]  
 $I \dots$  [A]  
 $i [-]$   
 $c [-]$

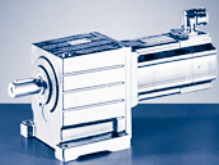

# GST [Nm]

## GST□□-□S (MCS)

$M_{2GN} \leq 1373 \text{ Nm}$

GST09-2S				12DC20	12DC41	12HC15	12HC30	12HC35	12LC20	12LC41	14DC15	14DC36	14HC15
				...500	...500	...500	...500	...500	...500	...500	...500	...500	...500
i	$M_{2GN}$	$J_G$	$M_1$	5.50	4.30	10.00	8.00	7.50	13.50	11.00	9.20	7.50	16.00
			$n_1$	1950	4050	1500	3000	3525	1950	4050	1500	3600	1500
			$I_{M230}$	5.2	8.8	7.6	10.5		11.8				
			$I_{M400}$	2.6	4.5	3.8		5.7	5.9	10.2	4.5	7.5	6.6
			$P_N$	1.10	1.80	1.60	2.50	2.80	2.80	4.70	1.45	2.80	2.50
			$J_M$	4.12	4.12	7.42	7.42	7.42	10.72	10.72	8.22	8.22	14.32
15.156	996	7.65	$M_2$										227
			c										4.2
			$n_{2 \text{ Eck}}$										99
			$n_{2 \text{ th}}$										99
15.156	1340	7.65	$M_2$										
			c										
			$n_{2 \text{ Eck}}$										
			$n_{2 \text{ th}}$										
17.222	1132	7.49	$M_2$										258
			c										4.2
			$n_{2 \text{ Eck}}$										87
			$n_{2 \text{ th}}$										87
17.222	1373	7.49	$M_2$										
			c										
			$n_{2 \text{ Eck}}$										
			$n_{2 \text{ th}}$										
20.533	675	4.50	$M_2$			194	155	145	265	216			
			c			3.4	3.8	3.9	2.5	2.5			
			$n_{2 \text{ Eck}}$			73	146	172	95	197			
			$n_{2 \text{ th}}$			73	146	172	95	160			
20.533	1055	4.50	$M_2$								174	142	311
			c								5.8	6.0	3.3
			$n_{2 \text{ Eck}}$								73	175	73
			$n_{2 \text{ th}}$								73	175	73
23.333	767	4.41	$M_2$			221	176	165	301	245			
			c			3.4	3.8	3.9	2.5	2.5			
			$n_{2 \text{ Eck}}$			64	129	151	84	174			
			$n_{2 \text{ th}}$			64	129	151	84	140			
23.333	1199	4.41	$M_2$								198	161	354
			c								5.8	6.0	3.3
			$n_{2 \text{ Eck}}$								64	154	64
			$n_{2 \text{ th}}$								64	154	64
24.933	703	3.38	$M_2$	127	99	237	189	177	323	263			
			c	5.3	5.5	2.9	3.3	3.3	2.2	2.2			
			$n_{2 \text{ Eck}}$	78	162	60	120	141	78	162			
			$n_{2 \text{ th}}$	78	162	60	120	141	78	151			
24.933	1096	3.38	$M_2$								214	174	380
			c								4.9	5.1	2.8
			$n_{2 \text{ Eck}}$								60	144	60
			$n_{2 \text{ th}}$								60	144	60
28.333	799	3.32	$M_2$	145	113	269	215	201	367	299			
			c	5.3	5.5	2.9	3.3	3.3	2.2	2.2			
			$n_{2 \text{ Eck}}$	69	143	53	106	124	69	143			
			$n_{2 \text{ th}}$	69	143	53	106	124	69	133			
28.333	1245	3.32	$M_2$								243	197	432
			c								4.9	5.1	2.8
			$n_{2 \text{ Eck}}$								53	127	53
			$n_{2 \text{ th}}$								53	127	53
32.267	729	2.25	$M_2$	166	130	309	246	231	419	342			
			c	4.2	4.4	2.3	2.6	2.7	1.7	1.7			
			$n_{2 \text{ Eck}}$	60	126	47	93	109	60	126			
			$n_{2 \text{ th}}$	60	126	46	93	109	60	124			

$M \dots [\text{Nm}]$   
 $n \dots [\text{r/min}]$   
 $J \dots [\text{kgcm}^2]$

$P \dots [\text{kW}]$   
 $I \dots [\text{A}]$   
 $i \dots [-]$   
 $c \dots [-]$

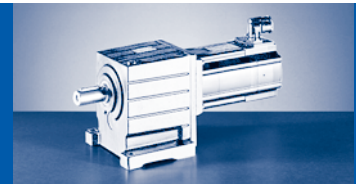

$M_{2GN} \leq 1373 \text{ Nm}$

14HC32	14LC15	14LC32	14PC14	14PC32	19FC14	19FC30	19JC14	19JC30	19PC14	19PC30	GST09-2S			
...500	...500	...500	...500	...500	...500	...500	...500	...500	...500	...500	$M_1$	$J_G$	$M_{2GN}$	i
14.00	23.00	17.20	30.00	21.00	27.00	21.00	40.00	29.00	51.00	32.00	$n_1$			
3225	1500	3225	1350	3225	1425	3000	1425	3000	1350	3000	$I_{M230}$			
11.9	9.7	15.0	10.8	15.6	8.6	14.0	12.3	18.5	14.3	19.0	$I_{M400}$			
4.70	3.60	5.80	4.20	7.10	4.00	6.60	6.00	9.10	7.20	10.00	$P_N$			
14.32	23.44	23.44	34.74	34.82	65.12	65.04	105.04	105.12	160.12	160.04	$J_M$			
199	331	246	435	303							$M_2$			
4.3	3.0	3.5	2.3	2.8							c	7.65	996	15.156
213	99	213	89	213							$n_2$ Eck			
197	99	189	89	182							$n_2$ th			
					387	300	580	418	744	463	$M_2$			
					3.4	3.9	2.3	2.8	1.8	2.6	c	7.65	1340	15.156
					94	198	94	198	89	198	$n_2$ Eck			
					94	146	94	146	89	146	$n_2$ th			
226	377	280	495	344							$M_2$			
4.3	3.0	3.5	2.3	2.8							c	7.49	1132	17.222
187	87	187	78	187							$n_2$ Eck			
173	87	166	78	160							$n_2$ th			
					442	342	661	477	847	527	$M_2$			
					3.0	3.5	2.1	2.6	1.6	2.3	c	7.49	1373	17.222
					83	174	83	174	78	174	$n_2$ Eck			
					83	128	83	128	78	128	$n_2$ th			
											$M_2$			
											c	4.50	675	20.533
											$n_2$ Eck			
											$n_2$ th			
272	452	337	593	413							$M_2$			
3.3	2.3	2.7	1.8	2.2							c	4.50	1055	20.533
157	73	157	66	157							$n_2$ Eck			
157	73	157	66	156							$n_2$ th			
											$M_2$			
											c	4.41	767	23.333
											$n_2$ Eck			
											$n_2$ th			
309	514	383	674	469							$M_2$			
3.3	2.3	2.7	1.8	2.2							c	4.41	1199	23.333
138	64	138	58	138							$n_2$ Eck			
138	64	138	58	137							$n_2$ th			
											$M_2$			
											c	3.38	703	24.933
											$n_2$ Eck			
											$n_2$ th			
332	551	410	722	503							$M_2$			
2.9	2.0	2.3	1.5	1.9							c	3.38	1096	24.933
129	60	129	54	129							$n_2$ Eck			
129	60	129	54	129							$n_2$ th			
											$M_2$			
											c	3.32	799	28.333
											$n_2$ Eck			
											$n_2$ th			
378	626	466	820	572							$M_2$			
2.9	2.0	2.3	1.5	1.9							c	3.32	1245	28.333
114	53	114	48	114							$n_2$ Eck			
114	53	114	48	114							$n_2$ th			
											$M_2$			
											c	2.25	729	32.267
											$n_2$ Eck			
											$n_2$ th			

M ... [Nm]  
n ... [r/min]  
J ... [kgcm<sup>2</sup>]

P ... [kW]  
I ... [A]  
i [-]  
c [-]



# GST [Nm]

## GST□□-□S (MCS)

$M_{2GN} \leq 1373 \text{ Nm}$

GST09-2S				12DC20	12DC41	12HC15	12HC30	12HC35	12LC20	12LC41	14DC15	14DC36	14HC15
				...500	...500	...500	...500	...500	...500	...500	...500	...500	...500
i	$M_{2GN}$	$J_G$	$M_1$	5.50	4.30	10.00	8.00	7.50	13.50	11.00	9.20	7.50	16.00
			$n_1$	1950	4050	1500	3000	3525	1950	4050	1500	3600	1500
			$I_{M230}$	5.2	8.8	7.6	10.5		11.8				
			$I_{M400}$	2.6	4.5	3.8		5.7	5.9	10.2	4.5	7.5	6.6
			$P_N$	1.10	1.80	1.60	2.50	2.80	2.80	4.70	1.45	2.80	2.50
			$J_M$	4.12	4.12	7.42	7.42	7.42	10.72	10.72	8.22	8.22	14.32
32.267	1136	2.25	$M_2$								279	227	494
			c								4.0	4.1	2.3
			$n_{2 \text{ Eck}}$								47	112	47
			$n_{2 \text{ th}}$								46	111	46
36.667	829	2.21	$M_2$	189	148	351	280	262	477	388			
			c	4.2	4.4	2.3	2.6	2.7	1.7	1.7			
			$n_{2 \text{ Eck}}$	53	111	41	82	96	53	111			
			$n_{2 \text{ th}}$	53	110	41	82	96	53	109			
36.667	1291	2.21	$M_2$								317	258	562
			c								4.0	4.1	2.3
			$n_{2 \text{ Eck}}$								41	98	41
			$n_{2 \text{ th}}$								41	98	41
39.160	738	1.64	$M_2$	204	159	376	300	281	511	416			
			c	3.5	3.7	1.9	2.2	2.2	1.4	1.4			
			$n_{2 \text{ Eck}}$	50	103	38	77	90	50	103			
			$n_{2 \text{ th}}$	50	103	38	77	90	50	103			
39.160	1150	1.64	$M_2$								341	278	602
			c								3.3	3.4	1.9
			$n_{2 \text{ Eck}}$								38	92	38
			$n_{2 \text{ th}}$								38	92	38
44.500	839	1.62	$M_2$	231	180	428	340	319	580	472			
			c	3.5	4.1	1.9	2.4	2.5	1.4	1.6			
			$n_{2 \text{ Eck}}$	44	91	34	67	79	44	91			
			$n_{2 \text{ th}}$	44	91	34	67	79	44	91			
44.500	1307	1.62	$M_2$								388	314	684
			c								3.3	3.8	1.9
			$n_{2 \text{ Eck}}$								34	81	34
			$n_{2 \text{ th}}$								34	81	34
49.500	748	1.12	$M_2$	259	202	478	380	357	647	527			
			c	2.8	3.3	1.6	2.0	2.0	1.2	1.3			
			$n_{2 \text{ Eck}}$	39	82	30	61	71	39	82			
			$n_{2 \text{ th}}$	39	82	30	61	71	39	82			
56.250	850	1.10	$M_2$	294	229	543	432	405	736	599			
			c	2.8	3.3	1.6	2.0	2.0	1.2	1.3			
			$n_{2 \text{ Eck}}$	35	72	27	53	63	35	72			
			$n_{2 \text{ th}}$	35	72	27	53	63	35	72			

$M \dots$  [Nm]  
 $n \dots$  [r/min]  
 $J \dots$  [kgcm<sup>2</sup>]

$P \dots$  [kW]  
 $I \dots$  [A]  
 $i \dots$  [-]  
 $c \dots$  [-]

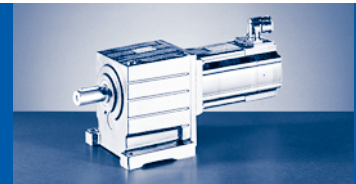

$M_{2GN} \leq 1373 \text{ Nm}$

14HC32	14LC15	14LC32	14PC14	14PC32	19FC14	19FC30	19JC14	19JC30	19PC14	19PC30	GST09-2S			
...500	...500	...500	...500	...500	...500	...500	...500	...500	...500	...500	$M_1$	$J_G$	$M_{2GN}$	i
14.00	23.00	17.20	30.00	21.00	27.00	21.00	40.00	29.00	51.00	32.00	$n_1$			
3225	1500	3225	1350	3225	1425	3000	1425	3000	1350	3000	$I_{M230}$			
11.9	9.7	15.0	10.8	15.6	8.6	14.0	12.3	18.5	14.3	19.0	$I_{M400}$			
4.70	3.60	5.80	4.20	7.10	4.00	6.60	6.00	9.10	7.20	10.00	$P_N$			
14.32	23.44	23.44	34.74	34.82	65.12	65.04	105.04	105.12	160.12	160.04	$J_M$			
432	716	534	937	654							$M_2$			
2.3	1.6	1.9	1.2	1.5							c	2.25	1136	32.267
100	47	100	42	100							$n_{2 \text{ Eck}}$			
100	46	100	42	100							$n_{2 \text{ th}}$			
											$M_2$			
											c	2.21	829	36.667
											$n_{2 \text{ Eck}}$			
											$n_{2 \text{ th}}$			
491	813	606	1065	743							$M_2$			
2.3	1.6	1.9	1.2	1.5							c	2.21	1291	36.667
88	41	88	37	88							$n_{2 \text{ Eck}}$			
88	41	88	37	88							$n_{2 \text{ th}}$			
											$M_2$			
											c	1.64	738	39.160
											$n_{2 \text{ Eck}}$			
											$n_{2 \text{ th}}$			
527	871	650	1140	796							$M_2$			
1.9	1.3	1.6	1.0	1.3							c	1.64	1150	39.160
82	38	82	35	82							$n_{2 \text{ Eck}}$			
82	38	82	34	82							$n_{2 \text{ th}}$			
											$M_2$			
											c	1.62	839	44.500
											$n_{2 \text{ Eck}}$			
											$n_{2 \text{ th}}$			
598	990	737	1295	903							$M_2$			
2.1	1.3	1.7	1.0	1.4							c	1.62	1307	44.500
73	34	73	30	73							$n_{2 \text{ Eck}}$			
72	34	72	30	72							$n_{2 \text{ th}}$			
											$M_2$			
											c	1.12	748	49.500
											$n_{2 \text{ Eck}}$			
											$n_{2 \text{ th}}$			
											$M_2$			
											c	1.10	850	56.250
											$n_{2 \text{ Eck}}$			

M ... [Nm]  
n ... [r/min]  
J ... [kgcm<sup>2</sup>]

P ... [kW]  
I ... [A]  
i [-]  
c [-]

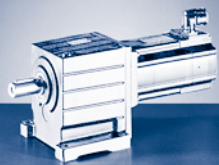

# GST [Nm]

## GST□□-□S (MCS)

$M_{2GN} \leq 1623 \text{ Nm}$

GST09-3S				06FC41	06IC41	09DC41	09FC38	09HC41	09LC41	12DC20	12DC41	12HC15	12HC30
				...500	...500	...500	...500	...500	...500	...500	...500	...500	...500
i	$M_{2GN}$	$J_G$	$M_1$	1.20	1.50	2.30	3.10	3.80	4.50	5.50	4.30	10.00	8.00
			$n_1$	4050	4050	4050	3750	4050	4050	1950	4050	1500	3000
			$I_{M230}$	2.9	3.2	4.6	5.0	6.8	8.4	5.2	8.8	7.6	10.5
			$I_{M400}$	1.5	1.6	2.3	2.5	3.4	4.2	2.6	4.5	3.8	
			$P_N$	0.51	0.64	1.00	1.20	1.60	1.90	1.10	1.80	1.60	2.50
			$J_M$	0.25	0.33	1.13	1.53	1.93	2.83	4.12	4.12	7.42	7.42
40.136	964	2.14	$M_2$					139	166				
			c					5.4	4.6				
			$n_{2 \text{ Eck}}$					101	101				
			$n_{2 \text{ th}}$					101	101				
40.136	1245	2.14	$M_2$							200		375	298
			c							5.9		3.3	3.7
			$n_{2 \text{ Eck}}$							49		37	75
			$n_{2 \text{ th}}$							49		37	75
40.136	1344	2.14	$M_2$										
			c										
			$n_{2 \text{ Eck}}$										
			$n_{2 \text{ th}}$										
43.267	892	1.55	$M_2$					150	180				
			c					5.1	4.3				
			$n_{2 \text{ Eck}}$					94	94				
			$n_{2 \text{ th}}$					94	94				
43.267	1152	1.55	$M_2$							218	169	406	322
			c							5.1	5.9	2.8	3.5
			$n_{2 \text{ Eck}}$							45	94	35	69
			$n_{2 \text{ th}}$							45	94	35	69
43.267	1290	1.55	$M_2$										
			c										
			$n_{2 \text{ Eck}}$										
			$n_{2 \text{ th}}$										
49.167	1013	1.53	$M_2$					171	204				
			c					5.1	4.3				
			$n_{2 \text{ Eck}}$					82	82				
			$n_{2 \text{ th}}$					82	82				
49.167	1310	1.53	$M_2$							247	192	461	366
			c							5.1	5.9	2.8	3.5
			$n_{2 \text{ Eck}}$							40	82	31	61
			$n_{2 \text{ th}}$							40	82	31	61
49.167	1466	1.53	$M_2$										
			c										
			$n_{2 \text{ Eck}}$										
			$n_{2 \text{ th}}$										
53.044	1093	1.38	$M_2$					184	220				
			c					5.1	4.3				
			$n_{2 \text{ Eck}}$					76	76				
			$n_{2 \text{ th}}$					76	76				
53.044	1379	1.38	$M_2$							267	207	498	395
			c							5.0	5.7	2.7	3.4
			$n_{2 \text{ Eck}}$							37	76	28	57
			$n_{2 \text{ th}}$							37	76	28	57
60.278	1242	1.37	$M_2$					209	250				
			c					5.1	4.3				
			$n_{2 \text{ Eck}}$					67	67				
			$n_{2 \text{ th}}$					67	67				
60.278	1565	1.37	$M_2$							304	235	566	449
			c							4.9	5.7	2.7	3.4
			$n_{2 \text{ Eck}}$							32	67	25	50
			$n_{2 \text{ th}}$							32	67	25	50

$M \dots$  [Nm]  
 $n \dots$  [r/min]  
 $J \dots$  [kgcm<sup>2</sup>]

$P \dots$  [kW]  
 $I \dots$  [A]  
 $i \dots$  [-]  
 $c \dots$  [-]

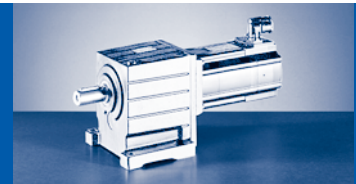

$M_{2GN} \leq 1623 \text{ Nm}$

12HC35	12LC20	12LC41	14DC15	14DC36	14HC15	14HC32	14LC15	14LC32	14PC14	14PC32	GST09-3S			
...500	...500	...500	...500	...500	...500	...500	...500	...500	...500	...500	$M_1$	$J_G$	$M_{2GN}$	i
7.50	13.50	11.00	9.20	7.50	16.00	14.00	23.00	17.20	30.00	21.00	$n_1$			
3525	1950	4050	1500	3600	1500	3225	1500	3225	1350	3225	$I_M 230$			
	11.8										$I_M 400$			
5.7	5.9	10.2	4.5	7.5	6.6	11.9	9.7	15.0	10.8	15.6	$P_N$			
2.80	2.80	4.70	1.45	2.80	2.50	4.70	3.60	5.80	4.20	7.10	$J_M$			
7.42	10.72	10.72	8.22	8.22	14.32	14.32	23.44	23.44	34.74	34.82	$M_2$			
											c	2.14	964	40.136
											$n_2$			
											Eck			
											$n_2$			
											th			
280	510	416									$M_2$	2.14	1245	40.136
3.7	2.4	2.4									c			
88	49	101									$n_2$			
88	49	101									Eck			
											$n_2$			
											th			
			343	279	606	530	877	654	1149	802	$M_2$	2.14	1344	40.136
			3.8	4.0	2.2	2.2	1.5	1.8	1.2	1.5	c			
			37	90	37	80	37	80	34	80	$n_2$			
			37	89	37	80	37	80	34	80	Eck			
											$n_2$			
											th			
											$M_2$	1.55	892	43.267
											c			
											$n_2$			
											Eck			
											$n_2$			
											th			
302	552	449									$M_2$	1.55	1152	43.267
3.5	2.1	2.3									c			
82	45	94									$n_2$			
81	45	94									Eck			
											$n_2$			
											th			
			371	301	655	572	947	705	1240	864	$M_2$	1.55	1290	43.267
			3.4	3.9	2.0	2.2	1.4	1.8	1.0	1.5	c			
			35	83	35	75	35	75	31	75	$n_2$			
			35	83	35	75	35	75	31	75	Eck			
											$n_2$			
											th			
											$M_2$	1.53	1013	49.167
											c			
											$n_2$			
											Eck			
											$n_2$			
											th			
343	627	510									$M_2$	1.53	1310	49.167
3.5	2.1	2.3									c			
72	40	82									$n_2$			
72	40	82									Eck			
											$n_2$			
											th			
			421	342	744	650	1077	802	1409	982	$M_2$	1.53	1466	49.167
			3.4	3.9	2.0	2.2	1.4	1.8	1.0	1.5	c			
			31	73	31	66	31	66	28	66	$n_2$			
			31	73	31	66	31	66	27	66	Eck			
											$n_2$			
											th			
											$M_2$	1.38	1093	53.044
											c			
											$n_2$			
											Eck			
											$n_2$			
											th			
371	677	550	457	371	805	703	1164	867		1062	$M_2$	1.38	1379	53.044
3.4	2.0	2.2	3.0	3.4	1.7	1.9	1.2	1.5		1.3	c			
67	37	76	28	68	28	61	28	61		61	$n_2$			
66	37	76	28	68	28	61	28	61		61	Eck			
											$n_2$			
											th			
											$M_2$	1.37	1242	60.278
											c			
											$n_2$			
											Eck			
											$n_2$			
											th			
421	769	625	519	421	915	799	1322	985		1206	$M_2$	1.37	1565	60.278
3.4	2.0	2.2	3.0	3.4	1.7	1.9	1.2	1.5		1.3	c			
59	32	67	25	60	25	54	25	54		54	$n_2$			
58	32	67	25	60	25	54	25	54		54	Eck			
											$n_2$			
											th			

M ... [Nm]  
n ... [r/min]  
J ... [kgcm<sup>2</sup>]

P ... [kW]  
I ... [A]  
i [-]  
c [-]

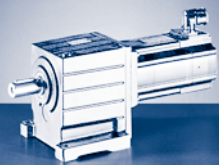

# GST [Nm]

## GST□□-□S (MCS)

$M_{2GN} \leq 1623 \text{ Nm}$

GST09-3S				06FC41	06IC41	09DC41	09FC38	09HC41	09LC41	12DC20	12DC41	12HC15	12HC30
				...500	...500	...500	...500	...500	...500	...500	...500	...500	...500
i	$M_{2GN}$	$J_G$	$M_1$	1.20	1.50	2.30	3.10	3.80	4.50	5.50	4.30	10.00	8.00
			$n_1$	4050	4050	4050	3750	4050	4050	1950	4050	1500	3000
			$I_{M230}$	2.9	3.2	4.6	5.0	6.8	8.4	5.2	8.8	7.6	10.5
			$I_{M400}$	1.5	1.6	2.3	2.5	3.4	4.2	2.6	4.5	3.8	
			$P_N$	0.51	0.64	1.00	1.20	1.60	1.90	1.10	1.80	1.60	2.50
			$J_M$	0.25	0.33	1.13	1.53	1.93	2.83	4.12	4.12	7.42	7.42
71.867	1477	1.17	$M_2$					250	298	366	284	679	540
			c				5.1	4.3	3.9	4.5	2.2	2.7	
			$n_{2 \text{ Eck}}$				56	56	27	56	21	42	
			$n_{2 \text{ th}}$				56	56	27	56	21	42	
81.667	1584	1.16	$M_2$					285	340	417	324	772	614
			c				4.8	4.1	3.7	4.3	2.0	2.5	
			$n_{2 \text{ Eck}}$				50	50	24	50	18	37	
			$n_{2 \text{ th}}$				50	50	24	50	18	37	
93.541	1545	0.71	$M_2$			265	329	392					
			c			5.2	4.1	3.5					
			$n_{2 \text{ Eck}}$			40	43	43					
			$n_{2 \text{ th}}$			40	43	43					
93.541	1613	0.71	$M_2$							480	373	886	706
			c							3.3	3.8	1.8	2.3
			$n_{2 \text{ Eck}}$							21	43	16	32
			$n_{2 \text{ th}}$							21	43	16	32
99.167	1596	1.07	$M_2$			281	349	416	510	397	941	749	
			c			5.0	4.0	3.4	3.1	3.5	1.7	2.1	
			$n_{2 \text{ Eck}}$			38	41	41	20	41	15	30	
			$n_{2 \text{ th}}$			38	41	41	20	41	15	30	
113.585	1613	0.65	$M_2$			237	324	402	478	586	456	1080	861
			c			5.9	4.5	3.5	3.0	2.7	3.1	1.5	1.9
			$n_{2 \text{ Eck}}$			36	33	36	36	17	36	13	26
			$n_{2 \text{ th}}$			36	33	36	36	17	36	13	26
129.074	1612	0.65	$M_2$			271	371	458	546	669	521	1230	980
			c			5.1	3.9	3.1	2.6	2.4	2.8	1.3	1.6
			$n_{2 \text{ Eck}}$			31	29	31	31	15	31	12	23
			$n_{2 \text{ th}}$			31	29	31	31	15	31	12	23
141.289	1316	0.46	$M_2$		192								
			c		5.9								
			$n_{2 \text{ Eck}}$		29								
			$n_{2 \text{ th}}$		29								
141.289	1613	0.46	$M_2$			299	407	503	599	734	571	1348	1075
			c			4.7	3.6	2.8	2.4	2.2	2.5	1.2	1.5
			$n_{2 \text{ Eck}}$			29	27	29	29	14	29	11	21
			$n_{2 \text{ th}}$			29	27	29	29	14	29	11	21
160.556	1495	0.46	$M_2$		218								
			c		5.9								
			$n_{2 \text{ Eck}}$		25								
			$n_{2 \text{ th}}$		25								
160.556	1623	0.46	$M_2$			341	465	574	682	836	651	1533	1223
			c			4.2	3.2	2.5	2.1	1.9	2.2	1.1	1.3
			$n_{2 \text{ Eck}}$			25	23	25	25	12	25	9	19
			$n_{2 \text{ th}}$			25	23	25	25	12	25	9	19
182.844	1365	0.30	$M_2$	199	252								
			c	5.9	4.7								
			$n_{2 \text{ Eck}}$	22	22								
			$n_{2 \text{ th}}$	22	22								
182.844	1613	0.30	$M_2$			391	532	656	779				
			c			3.6	2.8	2.2	1.9				
			$n_{2 \text{ Eck}}$			22	21	22	22				
			$n_{2 \text{ th}}$			22	21	22	22				

$M \dots$  [Nm]  
 $n \dots$  [r/min]  
 $J \dots$  [kgcm<sup>2</sup>]

$P \dots$  [kW]  
 $I \dots$  [A]  
 $i \dots$  [-]  
 $c \dots$  [-]

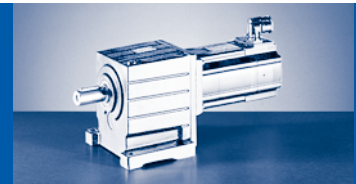

$M_{2GN} \leq 1623 \text{ Nm}$

12HC35	12LC20	12LC41	14DC15	14DC36	14HC15	14HC32	14LC15	14LC32	14PC14	14PC32	GST09-3S			
...500	...500	...500	...500	...500	...500	...500	...500	...500	...500	...500	$M_1$	$J_G$	$M_{2GN}$	i
7.50	13.50	11.00	9.20	7.50	16.00	14.00	23.00	17.20	30.00	21.00	$n_1$			
3525	1950	4050	1500	3600	1500	3225	1500	3225	1350	3225	$I_{M230}$			
	11.8										$I_{M400}$			
5.7	5.9	10.2	4.5	7.5	6.6	11.9	9.7	15.0	10.8	15.6	$P_N$			
2.80	2.80	4.70	1.45	2.80	2.50	4.70	3.60	5.80	4.20	7.10	$J_M$			
7.42	10.72	10.72	8.22	8.22	14.32	14.32	23.44	23.44	34.74	34.82	$M_2$			
506	921	749	623	506	1095	957		1179			c	1.17	1477	71.867
2.7	1.6	1.8	2.3	2.7	1.3	1.5		1.2			$n_2$ Eck			
49	27	56	21	50	21	45		45			$n_2$ th			
49	27	56	21	50	21	45		45						
576	1048	853	709	576	1245	1088		1340			$M_2$	1.16	1584	81.667
2.6	1.5	1.7	2.2	2.6	1.3	1.4		1.2			c			
43	24	50	18	44	18	40		40			$n_2$ Eck			
43	24	50	18	44	18	39		39			$n_2$ th			
											$M_2$	0.71	1545	93.541
											c			
											$n_2$ Eck			
											$n_2$ th			
661	1203	978									$M_2$	0.71	1613	93.541
2.3	1.3	1.5									c			
38	21	43									$n_2$ Eck			
38	21	43									$n_2$ th			
702	1276	1038	864	703	1516	1324					$M_2$	1.07	1596	99.167
2.1	1.3	1.4	1.8	2.1	1.1	1.2					c			
36	20	41	15	36	15	33					$n_2$ Eck			
36	20	41	15	36	15	33					$n_2$ th			
807	1464	1191									$M_2$	0.65	1613	113.585
1.9	1.1	1.2									c			
31	17	36									$n_2$ Eck			
31	17	36									$n_2$ th			
919		1356									$M_2$	0.65	1612	129.074
1.7		1.1									c			
27		31									$n_2$ Eck			
27		31									$n_2$ th			
											$M_2$	0.46	1316	141.289
											c			
											$n_2$ Eck			
											$n_2$ th			
1007											$M_2$	0.46	1613	141.289
1.5											c			
25											$n_2$ Eck			
25											$n_2$ th			
											$M_2$	0.46	1495	160.556
											c			
											$n_2$ Eck			
											$n_2$ th			
1147											$M_2$	0.46	1623	160.556
1.3											c			
22											$n_2$ Eck			
22											$n_2$ th			
											$M_2$	0.30	1365	182.844
											c			
											$n_2$ Eck			
											$n_2$ th			
											$M_2$	0.30	1613	182.844
											c			
											$n_2$ Eck			
											$n_2$ th			

M ... [Nm]  
n ... [r/min]  
J ... [kgcm<sup>2</sup>]

P ... [kW]  
I ... [A]  
i [-]  
c [-]

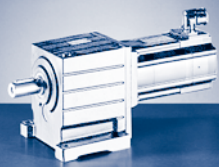

# GST [Nm]

## GST□□-□S (MCS)

$M_{2GN} \leq 1623 \text{ Nm}$

GST09-3S				06FC41	06IC41	09DC41	09FC38	09HC41	09LC41	12DC20	12DC41	12HC15	12HC30	
				...500	...500	...500	...500	...500	...500	...500	...500	...500	...500	
i	$M_{2GN}$	$J_G$	$M_1$	1.20	1.50	2.30	3.10	3.80	4.50	5.50	4.30	10.00	8.00	
			$n_1$	4050	4050	4050	3750	4050	4050	1950	4050	1500	3000	
			$I_{M230}$	2.9	3.2	4.6	5.0	6.8	8.4	5.2	8.8	7.6	10.5	
			$I_{M400}$	1.5	1.6	2.3	2.5	3.4	4.2	2.6	4.5	3.8		
			$P_N$	0.51	0.64	1.00	1.20	1.60	1.90	1.10	1.80	1.60	2.50	
			$J_M$	0.25	0.33	1.13	1.53	1.93	2.83	4.12	4.12	7.42	7.42	
207.778	1551	0.30	$M_2$	226	286									
			c	5.9	4.7									
			$n_{2 \text{ Eck}}$	20	20									
			$n_{2 \text{ th}}$	19	19									
			$M_2$			446	606	747	888					
207.778	1623	0.30	c			3.2	2.5	2.0	1.6					
			$n_{2 \text{ Eck}}$			20	18	20	20					
			$n_{2 \text{ th}}$			19	18	19	19					
			$M_2$	259	327	510	693	853	1013					
			c	5.4	4.3	2.8	2.1	1.7	1.4					
236.622	1613	0.28	$n_{2 \text{ Eck}}$	17	17	17	16	17	17					
			$n_{2 \text{ th}}$	17	17	17	16	17	17					
			$M_2$	277	350									
			c	4.9	3.9									
			$n_{2 \text{ Eck}}$	16	16									
252.167	1569	0.21	$n_{2 \text{ th}}$	16	16									
			$M_2$			545	739	910	1080					
			c			2.7	2.0	1.6	1.4					
			$n_{2 \text{ Eck}}$			16	15	16	16					
			$n_{2 \text{ th}}$			16	15	16	16					
268.889	1623	0.28	$M_2$	296	374	582	789	971	1153					
			c	4.8	3.8	2.5	1.9	1.5	1.3					
			$n_{2 \text{ Eck}}$	15	15	15	14	15	15					
			$n_{2 \text{ th}}$	15	15	15	14	15	15					
			$M_2$	363	457	709	961	1182	1403					
326.333	1623	0.20	c	3.9	3.1	2.1	1.6	1.2	1.1					
			$n_{2 \text{ Eck}}$	12	12	12	12	12	12					
			$n_{2 \text{ th}}$	12	12	12	11	12	12					
			$M_2$	405	511									
			c	3.5	2.8									
363.000	1613	0.26	$n_{2 \text{ Eck}}$	11	11									
			$n_{2 \text{ th}}$	11	11									
			$M_2$	463	582									
			c	3.1	2.5									
			$n_{2 \text{ Eck}}$	10	10									
412.500	1623	0.18	$n_{2 \text{ th}}$	10	10									

M ... [Nm]  
 n ... [r/min]  
 J ... [kgcm<sup>2</sup>]

P ... [kW]  
 I ... [A]  
 i [-]  
 c [-]

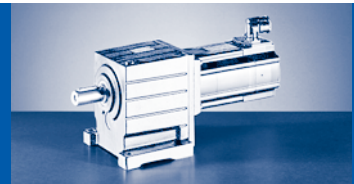

$M_{2GN} \leq 1623 \text{ Nm}$

12HC35	12LC20	12LC41	14DC15	14DC36	14HC15	14HC32	14LC15	14LC32	14PC14	14PC32	GST09-3S			
...500	...500	...500	...500	...500	...500	...500	...500	...500	...500	...500	$M_1$	$J_G$	$M_{2GN}$	i
7.50	13.50	11.00	9.20	7.50	16.00	14.00	23.00	17.20	30.00	21.00	$n_1$			
3525	1950	4050	1500	3600	1500	3225	1500	3225	1350	3225	$I_{M230}$			
	11.8										$I_{M400}$			
5.7	5.9	10.2	4.5	7.5	6.6	11.9	9.7	15.0	10.8	15.6	$P_N$			
2.80	2.80	4.70	1.45	2.80	2.50	4.70	3.60	5.80	4.20	7.10	$J_M$			
7.42	10.72	10.72	8.22	8.22	14.32	14.32	23.44	23.44	34.74	34.82	$M_2$			
											c	0.30	1551	207.778
											$n_2$			
											Eck			
											$n_2$			
											th			
											$M_2$	0.30	1623	207.778
											c			
											$n_2$			
											Eck			
											$n_2$			
											th			
											$M_2$	0.28	1613	236.622
											c			
											$n_2$			
											Eck			
											$n_2$			
											th			
											$M_2$	0.21	1569	252.167
											c			
											$n_2$			
											Eck			
											$n_2$			
											th			
											$M_2$	0.21	1623	252.167
											c			
											$n_2$			
											Eck			
											$n_2$			
											th			
											$M_2$	0.28	1623	268.889
											c			
											$n_2$			
											Eck			
											$n_2$			
											th			
											$M_2$	0.20	1623	326.333
											c			
											$n_2$			
											Eck			
											$n_2$			
											th			
											$M_2$	0.26	1613	363.000
											c			
											$n_2$			
											Eck			
											$n_2$			
											th			
											$M_2$	0.18	1623	412.500
											c			
											$n_2$			
											Eck			
											$n_2$			
											th			

M ... [Nm]  
n ... [r/min]  
J ... [kgcm<sup>2</sup>]

P ... [kW]  
I ... [A]  
i [-]  
c [-]

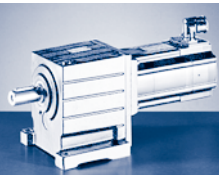

# GST [Nm]

## GST□□-□S (MCS)

$M_{2GN} \leq 2396 \text{ Nm}$

GST11-2S				14DC15	14DC36	14HC15	14HC32	14LC15	14LC32	14PC14
				...500	...500	...500	...500	...500	...500	...500
i	$M_{2GN}$	$J_G$	$M_1$	9.20	7.50	16.00	14.00	23.00	17.20	30.00
			$n_1$	1500	3600	1500	3225	1500	3225	1350
			$I_{M400}$	4.5	7.5	6.6	11.9	9.7	15.0	10.8
			$P_N$	1.45	2.80	2.50	4.70	3.60	5.80	4.20
			$J_M$	8.22	8.22	14.32	14.32	23.44	23.44	34.74
4.056	888	82.20	$M_2$ c $n_{2 \text{ Eck}}$ $n_{2 \text{ th}}$							
4.457	976	79.00	$M_2$ c $n_{2 \text{ Eck}}$ $n_{2 \text{ th}}$							
5.324	982	55.40	$M_2$ c $n_{2 \text{ Eck}}$ $n_{2 \text{ th}}$							
5.850	1080	53.50	$M_2$ c $n_{2 \text{ Eck}}$ $n_{2 \text{ th}}$							
6.400	1118	45.70	$M_2$ c $n_{2 \text{ Eck}}$ $n_{2 \text{ th}}$							
6.864	1502	67.50	$M_2$ c $n_{2 \text{ Eck}}$ $n_{2 \text{ th}}$							
7.800	1707	65.10	$M_2$ c $n_{2 \text{ Eck}}$ $n_{2 \text{ th}}$							
9.010	1663	46.80	$M_2$ c $n_{2 \text{ Eck}}$ $n_{2 \text{ th}}$							
9.856	1721	40.20	$M_2$ c $n_{2 \text{ Eck}}$ $n_{2 \text{ th}}$							
11.200	1956	39.00	$M_2$ c $n_{2 \text{ Eck}}$ $n_{2 \text{ th}}$							
12.571	1191	29.40	$M_2$ c $n_{2 \text{ Eck}}$ $n_{2 \text{ th}}$				163 5.4 257 186	271 4.2 119 119	202 4.4 257 178	357 3.3 107 107
12.571	1849	29.40	$M_2$ c $n_{2 \text{ Eck}}$ $n_{2 \text{ th}}$							
14.286	1353	28.70	$M_2$ c $n_{2 \text{ Eck}}$ $n_{2 \text{ th}}$				185 5.4 226 164	308 4.2 105 105	230 4.4 226 157	406 3.3 95 95

$M \dots$  [Nm]  
 $n \dots$  [r/min]  
 $J \dots$  [kgcm<sup>2</sup>]

$P \dots$  [kW]  
 $I \dots$  [A]  
 $i$  [-]  
 $c$  [-]

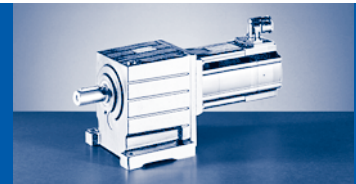

$M_{2GN} \leq 2396 \text{ Nm}$

14PC32	19FC14	19FC30	19JC14	19JC30	19PC14	19PC30	GST11-2S			
...500	...500	...500	...500	...500	...500	...500				
21.00	27.00	21.00	40.00	29.00	51.00	32.00	$M_1$	$J_G$	$M_{2GN}$	$i$
3225	1425	3000	1425	3000	1350	3000	$n_1$			
15.6	8.6	14.0	12.3	18.5	14.3	19.0	$I_{M400}$			
7.10	4.00	6.60	6.00	9.10	7.20	10.00	$P_N$			
34.82	65.12	65.04	105.04	105.12	160.12	160.04	$J_M$			
			150		194	120	$M_2$			
			5.6		4.4	5.6	c	82.20	888	4.056
			351		333	740	$n_{2 \text{ Eck}}$			
			351		333	428	$n_{2 \text{ th}}$			
			165		213	132	$M_2$			
			5.6		4.4	5.6	c	79.00	976	4.457
			320		303	673	$n_{2 \text{ Eck}}$			
			320		303	390	$n_{2 \text{ th}}$			
			199	143	256	159	$M_2$			
			4.8	5.2	3.7	4.7	c	55.40	982	5.324
			268	564	254	564	$n_{2 \text{ Eck}}$			
			268	374	254	365	$n_{2 \text{ th}}$			
			218	157	281	175	$M_2$			
			4.8	5.2	3.7	4.7	c	53.50	1080	5.850
			244	513	231	513	$n_{2 \text{ Eck}}$			
			244	340	231	333	$n_{2 \text{ th}}$			
			239	173	308	192	$M_2$			
			4.5	4.9	3.5	4.5	c	45.70	1118	6.400
			223	469	211	469	$n_{2 \text{ Eck}}$			
			223	316	211	310	$n_{2 \text{ th}}$			
			254		328	203	$M_2$			
			5.6		4.4	5.6	c	67.50	1502	6.864
			208		197	437	$n_{2 \text{ Eck}}$			
			208		197	253	$n_{2 \text{ th}}$			
			288		372	231	$M_2$			
			5.6		4.4	5.6	c	65.10	1707	7.800
			183		173	385	$n_{2 \text{ Eck}}$			
			183		173	223	$n_{2 \text{ th}}$			
			336	243	433	269	$M_2$			
			4.8	5.2	3.7	4.7	c	46.80	1663	9.010
			158	333	150	333	$n_{2 \text{ Eck}}$			
			158	221	150	216	$n_{2 \text{ th}}$			
			369	266	475	295	$M_2$			
			4.5	4.9	3.5	4.5	c	40.20	1721	9.856
			145	304	137	304	$n_{2 \text{ Eck}}$			
			145	205	137	201	$n_{2 \text{ th}}$			
			419	302	540	335	$M_2$			
			4.5	4.9	3.5	4.5	c	39.00	1956	11.200
			127	268	121	268	$n_{2 \text{ Eck}}$			
			127	181	121	177	$n_{2 \text{ th}}$			
249							$M_2$			
3.6							c	29.40	1191	12.571
257							$n_{2 \text{ Eck}}$			
171							$n_{2 \text{ th}}$			
	314	244	474	342	609	379	$M_2$			
	5.6	5.7	3.8	4.2	3.0	3.8	c	29.40	1849	12.571
	113	239	113	239	107	239	$n_{2 \text{ Eck}}$			
	113	176	113	176	107	173	$n_{2 \text{ th}}$			
283							$M_2$			
3.6							c	28.70	1353	14.286
226							$n_{2 \text{ Eck}}$			
150							$n_{2 \text{ th}}$			

M ... [Nm]  
n ... [r/min]  
J ... [kgcm<sup>2</sup>]

P ... [kW]  
I ... [A]  
i [-]  
c [-]

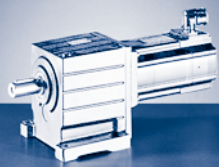

# GST [Nm]

## GST□□-□S (MCS)

$M_{2GN} \leq 2396 \text{ Nm}$

GST11-2S				14DC15	14DC36	14HC15	14HC32	14LC15	14LC32	14PC14
				...500	...500	...500	...500	...500	...500	...500
i	$M_{2GN}$	$J_G$	$M_1$	9.20	7.50	16.00	14.00	23.00	17.20	30.00
			$n_1$	1500	3600	1500	3225	1500	3225	1350
			$I_{M400}$	4.5	7.5	6.6	11.9	9.7	15.0	10.8
			$P_N$	1.45	2.80	2.50	4.70	3.60	5.80	4.20
			$J_M$	8.22	8.22	14.32	14.32	23.44	23.44	34.74
14.286	2101	28.70	$M_2$ c $n_{2 \text{ Eck}}$ $n_{2 \text{ th}}$							
15.400	1947	23.00	$M_2$ c $n_{2 \text{ Eck}}$ $n_{2 \text{ th}}$							
17.500	2212	22.50	$M_2$ c $n_{2 \text{ Eck}}$ $n_{2 \text{ th}}$							
20.289	1323	14.30	$M_2$ c $n_{2 \text{ Eck}}$ $n_{2 \text{ th}}$			305 4.2 74 74	266 4.2 159 147	444 2.9 74 74	330 3.4 159 141	583 2.2 67 67
20.289	2057	14.30	$M_2$ c $n_{2 \text{ Eck}}$ $n_{2 \text{ th}}$							
23.056	1503	14.10	$M_2$ c $n_{2 \text{ Eck}}$ $n_{2 \text{ th}}$			346 4.2 65 65	303 4.2 140 129	504 2.9 65 65	375 3.4 140 124	662 2.2 59 59
23.056	2338	14.10	$M_2$ c $n_{2 \text{ Eck}}$ $n_{2 \text{ th}}$							
24.933	1357	10.60	$M_2$ c $n_{2 \text{ Eck}}$ $n_{2 \text{ th}}$			377 3.5 60 60	330 3.5 129 129	548 2.4 60 60	408 2.9 129 129	719 1.9 54 54
24.933	2108	10.60	$M_2$ c $n_{2 \text{ Eck}}$ $n_{2 \text{ th}}$							
28.333	1542	10.40	$M_2$ c $n_{2 \text{ Eck}}$ $n_{2 \text{ th}}$			428 3.5 53 53	375 3.5 114 114	623 2.4 53 53	464 2.9 114 114	817 1.9 48 48
28.333	2396	10.40	$M_2$ c $n_{2 \text{ Eck}}$ $n_{2 \text{ th}}$							
32.267	1407	7.04	$M_2$ c $n_{2 \text{ Eck}}$ $n_{2 \text{ th}}$	276 4.9 47 46	225 5.1 112 111	492 2.8 47 46	430 2.8 100 100	713 2.0 47 46	531 2.3 100 100	934 1.5 42 42
36.667	1598	6.93	$M_2$ c $n_{2 \text{ Eck}}$ $n_{2 \text{ th}}$	314 4.9 41 41	256 5.1 98 98	559 2.8 41 41	489 2.8 88 88	810 2.0 41 41	604 2.3 88 88	1062 1.5 37 37

$M \dots$  [Nm]  
 $n \dots$  [r/min]  
 $J \dots$  [kgcm<sup>2</sup>]

$P \dots$  [kW]  
 $I \dots$  [A]  
 $i$  [-]  
 $c$  [-]

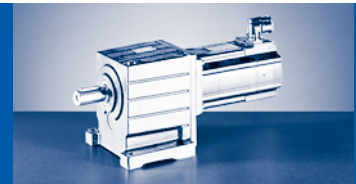

$M_{2GN} \leq 2396 \text{ Nm}$

14PC32	19FC14	19FC30	19JC14	19JC30	19PC14	19PC30	GST11-2S			
...500	...500	...500	...500	...500	...500	...500				
21.00	27.00	21.00	40.00	29.00	51.00	32.00	$M_1$	$J_G$	$M_{2GN}$	$i$
3225	1425	3000	1425	3000	1350	3000	$n_1$			
15.6	8.6	14.0	12.3	18.5	14.3	19.0	$I_{M400}$			
7.10	4.00	6.60	6.00	9.10	7.20	10.00	$P_N$			
34.82	65.12	65.04	105.04	105.12	160.12	160.04	$J_M$			
	356	277	538	389	693	431	$M_2$			
	5.6	5.7	3.8	4.2	3.0	3.8	$c$	28.70	2101	14.286
	100	210	100	210	95	210	$n_{2\text{ Eck}}$			
	100	155	100	155	95	152	$n_{2\text{ th}}$			
	388	299	584	420	750	465	$M_2$			
	4.8	5.6	3.3	4.1	2.6	3.7	$c$	23.00	1947	15.400
	93	195	93	195	88	195	$n_{2\text{ Eck}}$			
	93	144	93	144	88	144	$n_{2\text{ th}}$			
	440	340	663	477	852	528	$M_2$			
	4.8	5.6	3.3	4.1	2.6	3.7	$c$	22.50	2212	17.500
	81	171	81	171	77	171	$n_{2\text{ Eck}}$			
	81	126	81	126	77	126	$n_{2\text{ th}}$			
406							$M_2$			
2.8							$c$	14.30	1323	20.289
159							$n_{2\text{ Eck}}$			
136							$n_{2\text{ th}}$			
	516	399	774	558	993	617	$M_2$			
	3.9	4.5	2.6	3.3	2.1	3.0	$c$	14.30	2057	20.289
	70	148	70	148	67	148	$n_{2\text{ Eck}}$			
	70	109	70	109	67	109	$n_{2\text{ th}}$			
461							$M_2$			
2.8							$c$	14.10	1503	23.056
140							$n_{2\text{ Eck}}$			
119							$n_{2\text{ th}}$			
	586	453	880	634	1128	701	$M_2$			
	3.9	4.5	2.6	3.3	2.1	3.0	$c$	14.10	2338	23.056
	62	130	62	130	59	130	$n_{2\text{ Eck}}$			
	62	96	62	96	59	96	$n_{2\text{ th}}$			
501							$M_2$			
2.4							$c$	10.60	1357	24.933
129							$n_{2\text{ Eck}}$			
125							$n_{2\text{ th}}$			
	638	494	956	689	1225	762	$M_2$			
	3.2	3.7	2.2	2.7	1.7	2.5	$c$	10.60	2108	24.933
	57	120	57	120	54	120	$n_{2\text{ Eck}}$			
	57	89	57	89	54	89	$n_{2\text{ th}}$			
569							$M_2$			
2.4							$c$	10.40	1542	28.333
114							$n_{2\text{ Eck}}$			
110							$n_{2\text{ th}}$			
	725	561	1086	783	1392	866	$M_2$			
	3.2	3.7	2.2	2.7	1.7	2.5	$c$	10.40	2396	28.333
	50	106	50	106	48	106	$n_{2\text{ Eck}}$			
	50	78	50	78	48	78	$n_{2\text{ th}}$			
651							$M_2$			
1.9							$c$	7.04	1407	32.267
100							$n_{2\text{ Eck}}$			
100							$n_{2\text{ th}}$			
740							$M_2$			
1.9							$c$	6.93	1598	36.667
88							$n_{2\text{ Eck}}$			
88							$n_{2\text{ th}}$			

M ... [Nm]  
n ... [r/min]  
J ... [kgcm<sup>2</sup>]

P ... [kW]  
I ... [A]  
i [-]  
c [-]

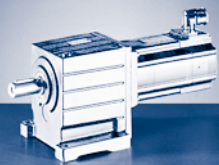

# GST [Nm]

## GST□□-□S (MCS)

$M_{2GN} \leq 2396 \text{ Nm}$

GST11-2S				14DC15	14DC36	14HC15	14HC32	14LC15	14LC32	14PC14
				...500	...500	...500	...500	...500	...500	...500
i	$M_{2GN}$	$J_G$	$M_1$	9.20	7.50	16.00	14.00	23.00	17.20	30.00
			$n_1$	1500	3600	1500	3225	1500	3225	1350
			$I_{M400}$	4.5	7.5	6.6	11.9	9.7	15.0	10.8
			$P_N$	1.45	2.80	2.50	4.70	3.60	5.80	4.20
			$J_M$	8.22	8.22	14.32	14.32	23.44	23.44	34.74
39.160	1424	5.15	$M_2$	338	275	599	524	868	647	1137
			c	4.1	4.2	2.3	2.4	1.6	1.9	1.3
			$n_{2Eck}$	38	92	38	82	38	82	35
			$n_{2th}$	38	92	38	82	38	82	34
44.500	1618	5.08	$M_2$	385	311	681	594	987	734	1292
			c	4.1	4.7	2.3	2.6	1.6	2.1	1.3
			$n_{2Eck}$	34	81	34	73	34	73	30
			$n_{2th}$	34	81	34	72	34	72	30
49.500	1441	3.52	$M_2$	432	350	761	665	1101	820	1441
			c	3.3	3.8	1.9	2.1	1.3	1.7	1.0
			$n_{2Eck}$	30	73	30	65	30	65	27
			$n_{2th}$	30	73	30	65	30	65	27
56.250	1637	3.44	$M_2$	490	398	865	755	1251	932	1637
			c	3.3	3.8	1.9	2.1	1.3	1.7	1.0
			$n_{2Eck}$	27	64	27	57	27	57	24
			$n_{2th}$	27	64	27	57	27	57	24

$M \dots$  [Nm]  
 $n \dots$  [r/min]  
 $J \dots$  [kgcm<sup>2</sup>]

$P \dots$  [kW]  
 $I \dots$  [A]  
 $i$  [-]  
 $c$  [-]

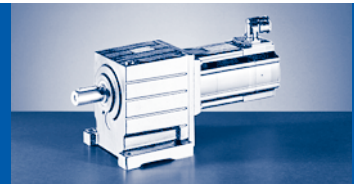

$M_{2GN} \leq 2396 \text{ Nm}$

14PC32	19FC14	19FC30	19JC14	19JC30	19PC14	19PC30	GST11-2S			
...500	...500	...500	...500	...500	...500	...500	$M_1$	$J_G$	$M_{2GN}$	$i$
21.00	27.00	21.00	40.00	29.00	51.00	32.00	$n_1$			
3225	1425	3000	1425	3000	1350	3000	$l_{M400}$			
15.6	8.6	14.0	12.3	18.5	14.3	19.0	$P_N$			
7.10	4.00	6.60	6.00	9.10	7.20	10.00	$J_M$			
34.82	65.12	65.04	105.04	105.12	160.12	160.04	$M_2$			
793							$c$	5.15	1424	39.160
1.6							$n_{2 \text{ Eck}}$			
82							$n_{2 \text{ th}}$			
82							$M_2$			
900							$c$	5.08	1618	44.500
1.7							$n_{2 \text{ Eck}}$			
73							$n_{2 \text{ th}}$			
72							$M_2$			
1004							$c$	3.52	1441	49.500
1.4							$n_{2 \text{ Eck}}$			
65							$n_{2 \text{ th}}$			
65							$M_2$			
1141							$c$	3.44	1637	56.250
1.4							$n_{2 \text{ Eck}}$			
57							$n_{2 \text{ th}}$			
57										

M ... [Nm]  
n ... [r/min]  
J ... [kgcm<sup>2</sup>]

P ... [kW]  
I ... [A]  
i [-]  
c [-]

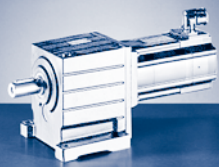

# GST [Nm]

## GST□□-□S (MCS)

$M_{2GN} \leq 2848 \text{ Nm}$

GST11-3S				09DC41	09FC38	09HC41	09LC41	12DC20	12DC41	12HC15	12HC30	12HC35
				...500	...500	...500	...500	...500	...500	...500	...500	...500
i	$M_{2GN}$	$J_G$	$M_1$	2.30	3.10	3.80	4.50	5.50	4.30	10.00	8.00	7.50
			$n_1$	4050	3750	4050	4050	1950	4050	1500	3000	3525
			$I_{M230}$	4.6	5.0	6.8	8.4	5.2	8.8	7.6	10.5	
			$I_{M400}$	2.3	2.5	3.4	4.2	2.6	4.5	3.8		5.7
			$P_N$	1.00	1.20	1.60	1.90	1.10	1.80	1.60	2.50	2.80
			$J_M$	1.13	1.53	1.93	2.83	4.12	4.12	7.42	7.42	7.42
40.816	1216	6.36	$M_2$ c $n_{2 \text{ Eck}}$ $n_{2 \text{ th}}$				167 5.7 99 99					
40.816	1565	6.36	$M_2$ c $n_{2 \text{ Eck}}$ $n_{2 \text{ th}}$							378 4.0 37 37	301 4.5 74 74	282 4.6 86 86
40.816	2165	6.36	$M_2$ c $n_{2 \text{ Eck}}$ $n_{2 \text{ th}}$									
44.000	1687	5.66	$M_2$ c $n_{2 \text{ Eck}}$ $n_{2 \text{ th}}$							407 4.0 34 34	322 5.0 68 68	302 5.1 80 80
44.000	2334	5.66	$M_2$ c $n_{2 \text{ Eck}}$ $n_{2 \text{ th}}$									
50.000	1917	5.60	$M_2$ c $n_{2 \text{ Eck}}$ $n_{2 \text{ th}}$							463 4.0 30 30	366 5.0 60 60	343 5.1 71 71
50.000	2652	5.60	$M_2$ c $n_{2 \text{ Eck}}$ $n_{2 \text{ th}}$									
57.968	2222	4.77	$M_2$ c $n_{2 \text{ Eck}}$ $n_{2 \text{ th}}$							537 4.0 26 26	425 5.0 52 52	398 5.1 61 61
57.968	2577	4.77	$M_2$ c $n_{2 \text{ Eck}}$ $n_{2 \text{ th}}$									
61.250	2017	4.08	$M_2$ c $n_{2 \text{ Eck}}$ $n_{2 \text{ th}}$							570 3.5 25 24	452 4.3 49 49	424 4.4 58 58
61.250	2725	4.08	$M_2$ c $n_{2 \text{ Eck}}$ $n_{2 \text{ th}}$									
71.011	2339	3.52	$M_2$ c $n_{2 \text{ Eck}}$ $n_{2 \text{ th}}$							661 3.5 21 21	524 4.3 42 42	491 4.4 50 50
71.011	2637	3.52	$M_2$ c $n_{2 \text{ Eck}}$ $n_{2 \text{ th}}$									

$M \dots$  [Nm]  
 $n \dots$  [r/min]  
 $J \dots$  [kgcm<sup>2</sup>]

$P \dots$  [kW]  
 $I \dots$  [A]  
 $i \dots$  [-]  
 $c \dots$  [-]

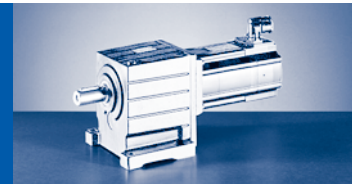

$M_{2GN} \leq 2848 \text{ Nm}$

12LC20	12LC41	14DC15	14DC36	14HC15	14HC32	14LC15	14LC32	14PC14	14PC32	GST11-3S			
...500	...500	...500	...500	...500	...500	...500	...500	...500	...500	$M_1$	$J_G$	$M_{2GN}$	i
13.50	11.00	9.20	7.50	16.00	14.00	23.00	17.20	30.00	21.00	$n_1$			
1950	4050	1500	3600	1500	3225	1500	3225	1350	3225	$I_{M230}$			
11.8										$I_{M400}$			
5.9	10.2	4.5	7.5	6.6	11.9	9.7	15.0	10.8	15.6	$P_N$			
2.80	4.70	1.45	2.80	2.50	4.70	3.60	5.80	4.20	7.10	$J_M$			
10.72	10.72	8.22	8.22	14.32	14.32	23.44	23.44	34.74	34.82	$M_2$			
										c	6.36	1216	40.816
										$n_2$			
										Eck			
										$n_2$			
										th			
516	420									$M_2$	6.36	1565	40.816
3.0	3.0									c			
48	99									$n_2$			
48	99									Eck			
										$n_2$			
										th			
				608	532	884	658	1160	808	$M_2$	6.36	2165	40.816
				3.5	3.5	2.4	2.8	1.9	2.3	c			
				37	79	37	79	33	79	$n_2$			
				37	79	37	79	33	79	Eck			
										$n_2$			
										th			
556	451									$M_2$	5.66	1687	44.000
3.0	3.3									c			
44	92									$n_2$			
44	92									Eck			
										$n_2$			
										th			
				655	571	953	707	1250	868	$M_2$	5.66	2334	44.000
				3.5	3.9	2.4	3.2	1.9	2.6	c			
				34	73	34	73	31	73	$n_2$			
				34	73	34	73	31	73	Eck			
										$n_2$			
										th			
632	513									$M_2$	5.60	1917	50.000
3.0	3.3									c			
39	81									$n_2$			
39	81									Eck			
										$n_2$			
										th			
				745	649	1083	803	1421	987	$M_2$	5.60	2652	50.000
				3.5	3.9	2.4	3.2	1.9	2.6	c			
				30	65	30	65	27	65	$n_2$			
				30	65	30	65	27	65	Eck			
										$n_2$			
										th			
732	595									$M_2$	4.77	2222	57.968
3.0	3.3									c			
34	70									$n_2$			
34	70									Eck			
										$n_2$			
										th			
		488	394	869	757	1261	937	1652	1149	$M_2$	4.77	2577	57.968
		5.1	5.8	2.9	3.2	2.0	2.6	1.6	2.2	c			
		26	62	26	56	26	56	23	56	$n_2$			
		26	62	26	56	26	56	23	56	Eck			
										$n_2$			
										th			
777	632									$M_2$	4.08	2017	61.250
2.6	2.8									c			
32	66									$n_2$			
32	66									Eck			
										$n_2$			
										th			
		516	417	918	800	1332	989	1746	1214	$M_2$	4.08	2725	61.250
		5.1	5.8	2.9	3.3	2.0	2.6	1.6	2.2	c			
		25	59	25	53	25	53	22	53	$n_2$			
		24	59	24	53	24	53	22	53	Eck			
										$n_2$			
										th			
901	732									$M_2$	3.52	2339	71.011
2.6	2.8									c			
28	57									$n_2$			
27	57									Eck			
										$n_2$			
										th			
		603	488	1070	933	1550	1153	2030	1413	$M_2$	3.52	2637	71.011
		4.2	4.9	2.4	2.7	1.7	2.2	1.3	1.8	c			
		21	51	21	45	21	45	19	45	$n_2$			
		21	51	21	45	21	45	19	45	Eck			
										$n_2$			
										th			

M ... [Nm]  
n ... [r/min]  
J ... [kgcm<sup>2</sup>]

P ... [kW]  
I ... [A]  
i [-]  
c [-]

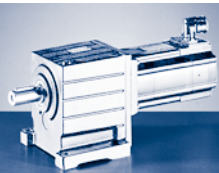

# GST [Nm]

## GST□□-□S (MCS)

$M_{2GN} \leq 2848 \text{ Nm}$

GST11-3S				09DC41	09FC38	09HC41	09LC41	12DC20	12DC41	12HC15	12HC30	12HC35		
				...500	...500	...500	...500	...500	...500	...500	...500	...500		
i	$M_{2GN}$	$J_G$	$M_1$	2.30	3.10	3.80	4.50	5.50	4.30	10.00	8.00	7.50		
			$n_1$	4050	3750	4050	4050	1950	4050	1500	3000	3525		
			$I_{M230}$	4.6	5.0	6.8	8.4	5.2	8.8	7.6	10.5			
			$I_{M400}$	2.3	2.5	3.4	4.2	2.6	4.5	3.8		5.7		
			$P_N$	1.00	1.20	1.60	1.90	1.10	1.80	1.60	2.50	2.80		
			$J_M$	1.13	1.53	1.93	2.83	4.12	4.12	7.42	7.42	7.42		
80.694	2658	3.50	$M_2$							751	596	558		
			c								3.5	4.3	4.4	
			$n_{2 \text{ Eck}}$									19	37	44
			$n_{2 \text{ th}}$									19	37	44
80.694	2787	3.50	$M_2$											
			c											
			$n_{2 \text{ Eck}}$											
			$n_{2 \text{ th}}$											
87.267	2657	3.22	$M_2$					436		815	646	606		
			c					5.8		3.2	4.0	4.0		
			$n_{2 \text{ Eck}}$					22		17	34	40		
			$n_{2 \text{ th}}$					22		17	34	40		
99.167	2810	3.20	$M_2$					497		928	737	690		
			c					5.4		3.0	3.7	3.8		
			$n_{2 \text{ Eck}}$					20		15	30	36		
			$n_{2 \text{ th}}$					20		15	30	36		
112.933	2695	2.93	$M_2$					572	443	1062	844	791		
			c					4.5	5.3	2.5	3.1	3.2		
			$n_{2 \text{ Eck}}$					17	36	13	27	31		
			$n_{2 \text{ th}}$					17	36	13	27	31		
129.074	2651	1.94	$M_2$			449	536							
			c			5.1	4.3							
			$n_{2 \text{ Eck}}$			31	31							
			$n_{2 \text{ th}}$			31	31							
129.074	2810	1.94	$M_2$					656	509	1217	968	907		
			c					4.1	4.8	2.3	2.9	2.9		
			$n_{2 \text{ Eck}}$					15	31	12	23	27		
			$n_{2 \text{ th}}$					15	31	12	23	27		
146.993	2695	1.77	$M_2$		414	514	613	753	585	1391	1107	1038		
			c		5.8	4.6	3.9	3.5	4.0	1.9	2.4	2.4		
			$n_{2 \text{ Eck}}$		26	28	28	13	28	10	20	24		
			$n_{2 \text{ th}}$		26	28	28	13	28	10	20	24		
158.194	2779	1.40	$M_2$		447	554	661							
			c		5.5	4.4	3.7							
			$n_{2 \text{ Eck}}$		24	26	26							
			$n_{2 \text{ th}}$		24	26	26							
158.194	2810	1.40	$M_2$					811	630	1498	1193	1118		
			c					3.4	3.9	1.9	2.3	2.4		
			$n_{2 \text{ Eck}}$					12	26	10	19	22		
			$n_{2 \text{ th}}$					12	26	9	19	22		
180.156	2695	1.29	$M_2$		513	636	757	929	723	1712	1364	1278		
			c		4.7	3.7	3.2	2.9	3.3	1.6	2.0	2.0		
			$n_{2 \text{ Eck}}$		21	23	23	11	23	8	17	20		
			$n_{2 \text{ th}}$		21	22	22	11	22	8	17	20		
207.778	2810	0.88	$M_2$	435	595	736	876	1074	836	1977	1576	1477		
			c	5.6	4.2	3.4	2.9	2.6	3.0	1.4	1.8	1.8		
			$n_{2 \text{ Eck}}$	20	18	20	20	9	20	7	14	17		
			$n_{2 \text{ th}}$	19	18	19	19	9	19	7	14	17		
236.622	2695	0.82	$M_2$	500	682	843	1003	1229	957	2257	1800	1687		
			c	4.7	3.6	2.8	2.4	2.2	2.5	1.2	1.5	1.5		
			$n_{2 \text{ Eck}}$	17	16	17	17	8	17	6	13	15		
			$n_{2 \text{ th}}$	17	16	17	17	8	17	6	13	15		

$M \dots$  [Nm]  
 $n \dots$  [r/min]  
 $J \dots$  [kgcm<sup>2</sup>]

$P \dots$  [kW]  
 $I \dots$  [A]  
 $i \dots$  [-]  
 $c \dots$  [-]

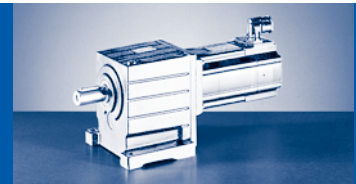

$M_{2GN} \leq 2848 \text{ Nm}$

12LC20	12LC41	14DC15	14DC36	14HC15	14HC32	14LC15	14LC32	14PC14	14PC32	GST11-3S			
...500	...500	...500	...500	...500	...500	...500	...500	...500	...500	$M_1$	$J_G$	$M_{2GN}$	i
13.50	11.00	9.20	7.50	16.00	14.00	23.00	17.20	30.00	21.00	$n_1$			
1950	4050	1500	3600	1500	3225	1500	3225	1350	3225	$I_{M230}$			
11.8										$I_{M400}$			
5.9	10.2	4.5	7.5	6.6	11.9	9.7	15.0	10.8	15.6	$P_N$			
2.80	4.70	1.45	2.80	2.50	4.70	3.60	5.80	4.20	7.10	$J_M$			
10.72	10.72	8.22	8.22	14.32	14.32	23.44	23.44	34.74	34.82	$M_2$			
1024	832									c			
2.6	2.8									$n_{2 \text{ Eck}}$	3.50	2658	80.694
24	50									$n_{2 \text{ th}}$			
24	50									$M_2$			
		688	557	1218	1062	1763	1312	2309	1608	c			
		3.9	4.5	2.3	2.5	1.6	2.1	1.2	1.7	$n_{2 \text{ Eck}}$	3.50	2787	80.694
		19	45	19	40	19	40	17	40	$n_{2 \text{ th}}$			
		19	44	19	40	19	40	17	40	$M_2$			
1110	902	747	606	1321	1153	1910	1422	2500	1743	c			
2.4	2.6	3.5	4.0	2.0	2.2	1.4	1.8	1.1	1.5	$n_{2 \text{ Eck}}$	3.22	2657	87.267
22	46	17	41	17	37	17	37	16	37	$n_{2 \text{ th}}$			
22	46	17	41	17	37	17	37	15	37	$M_2$			
1263	1027	852	691	1503	1312	2173	1618		1982	c			
2.2	2.4	3.2	3.7	1.9	2.1	1.3	1.7		1.4	$n_{2 \text{ Eck}}$	3.20	2810	99.167
20	41	15	36	15	33	15	33		33	$n_{2 \text{ th}}$			
20	41	15	36	15	33	15	33		33	$M_2$			
1444	1174	975	791	1717	1499	2480	1848		2263	c			
1.9	2.1	2.7	3.1	1.6	1.7	1.1	1.4		1.2	$n_{2 \text{ Eck}}$	2.93	2695	112.933
17	36	13	32	13	29	13	29		29	$n_{2 \text{ th}}$			
17	36	13	32	13	29	13	29		29	$M_2$			
										c			
										$n_{2 \text{ Eck}}$	1.94	2651	129.074
										$n_{2 \text{ th}}$			
1653	1344	1117	907	1965	1716		2115		2589	$M_2$			
1.7	1.9	2.5	2.9	1.4	1.6		1.3		1.1	c			
15	31	12	28	12	25		25		25	$n_{2 \text{ Eck}}$	1.94	2810	129.074
15	31	12	28	12	25		25		25	$n_{2 \text{ th}}$			
1888	1536	1278	1038	2243	1960		2414			$M_2$			
1.4	1.6	2.1	2.4	1.2	1.3		1.1			c			
13	28	10	25	10	22		22			$n_{2 \text{ Eck}}$	1.77	2695	146.993
13	28	10	24	10	22		22			$n_{2 \text{ th}}$			
										$M_2$			
										c			
										$n_{2 \text{ Eck}}$	1.40	2779	158.194
										$n_{2 \text{ th}}$			
2033	1654	1376	1118	2415	2110		2599			$M_2$			
1.4	1.5	2.0	2.3	1.2	1.3		1.1			c			
12	26	10	23	10	20		20			$n_{2 \text{ Eck}}$	1.40	2810	158.194
12	26	9	23	9	20		20			$n_{2 \text{ th}}$			
2320	1888	1572	1278		2408					$M_2$			
1.2	1.3	1.7	2.0		1.1					c			
11	23	8	20		18					$n_{2 \text{ Eck}}$	1.29	2695	180.156
11	22	8	20		18					$n_{2 \text{ th}}$			
2679	2180									$M_2$			
1.1	1.2									c			
9	20									$n_{2 \text{ Eck}}$	0.88	2810	207.778
9	19									$n_{2 \text{ th}}$			
										$M_2$			
										c			
										$n_{2 \text{ Eck}}$	0.82	2695	236.622
										$n_{2 \text{ th}}$			

M ... [Nm]  
n ... [r/min]  
J ... [kgcm<sup>2</sup>]

P ... [kW]  
I ... [A]  
i [-]  
c [-]

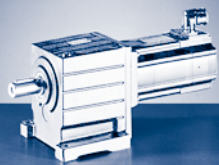

# GST [Nm]

## GST□□-□S (MCS)

$M_{2GN} \leq 2848 \text{ Nm}$

GST11-3S				09DC41	09FC38	09HC41	09LC41	12DC20	12DC41	12HC15	12HC30	12HC35
				...500	...500	...500	...500	...500	...500	...500	...500	...500
i	$M_{2GN}$	$J_G$	$M_1$	2.30	3.10	3.80	4.50	5.50	4.30	10.00	8.00	7.50
			$n_1$	4050	3750	4050	4050	1950	4050	1500	3000	3525
			$I_{M230}$	4.6	5.0	6.8	8.4	5.2	8.8	7.6	10.5	
			$I_{M400}$	2.3	2.5	3.4	4.2	2.6	4.5	3.8		5.7
			$P_N$	1.00	1.20	1.60	1.90	1.10	1.80	1.60	2.50	2.80
			$J_M$	1.13	1.53	1.93	2.83	4.12	4.12	7.42	7.42	7.42
252.167	2810	0.63	$M_2$	533	728	899	1069	1310	1020	2406	1919	1798
			c	4.6	3.5	2.8	2.4	2.1	2.5	1.2	1.5	1.5
			$n_{2 \text{ Eck}}$	16	15	16	16	8	16	6	12	14
			$n_{2 \text{ th}}$	16	15	16	16	8	16	6	12	14
268.889	2848	0.82	$M_2$	570	777	960	1141	1398	1090	2567	2047	1919
			c	4.4	3.3	2.6	2.2	2.0	2.3	1.1	1.4	1.4
			$n_{2 \text{ Eck}}$	15	14	15	15	7	15	6	11	13
			$n_{2 \text{ th}}$	15	14	15	15	7	15	6	11	13
326.333	2848	0.59	$M_2$	698	949	1171	1391	1703	1328		2491	2335
			c	3.6	2.7	2.2	1.8	1.7	1.9		1.1	1.2
			$n_{2 \text{ Eck}}$	12	12	12	12	6	12		9	11
			$n_{2 \text{ th}}$	12	11	12	12	6	12		9	11
363.000	2695	0.76	$M_2$	781	1060	1307	1552					
			c	3.1	2.3	1.9	1.6					
			$n_{2 \text{ Eck}}$	11	10	11	11					
			$n_{2 \text{ th}}$	11	10	11	11					
412.500	2848	0.55	$M_2$	889	1207	1487	1766					
			c	2.8	2.2	1.7	1.5					
			$n_{2 \text{ Eck}}$	10	9	10	10					
			$n_{2 \text{ th}}$	10	9	10	10					

M ... [Nm]  
n ... [r/min]  
J ... [kgcm<sup>2</sup>]

P ... [kW]  
I ... [A]  
i [-]  
c [-]

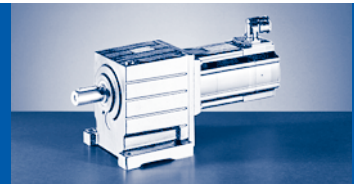

$M_{2GN} \leq 2848 \text{ Nm}$

12LC20	12LC41	14DC15	14DC36	14HC15	14HC32	14LC15	14LC32	14PC14	14PC32	GST11-3S			
...500	...500	...500	...500	...500	...500	...500	...500	...500	...500	$M_1$	$J_G$	$M_{2GN}$	i
13.50	11.00	9.20	7.50	16.00	14.00	23.00	17.20	30.00	21.00	$n_1$			
1950	4050	1500	3600	1500	3225	1500	3225	1350	3225	$I_{M230}$			
11.8										$I_{M400}$			
5.9	10.2	4.5	7.5	6.6	11.9	9.7	15.0	10.8	15.6	$P_N$			
2.80	4.70	1.45	2.80	2.50	4.70	3.60	5.80	4.20	7.10	$J_M$			
10.72	10.72	8.22	8.22	14.32	14.32	23.44	23.44	34.74	34.82	$M_2$			
										c			
										$n_{2 \text{ Eck}}$	0.63	2810	252.167
										$n_{2 \text{ th}}$			
										$M_2$			
										c			
										$n_{2 \text{ Eck}}$	0.82	2848	268.889
										$n_{2 \text{ th}}$			
										$M_2$			
										c			
										$n_{2 \text{ Eck}}$	0.59	2848	326.333
										$n_{2 \text{ th}}$			
										$M_2$			
										c			
										$n_{2 \text{ Eck}}$	0.76	2695	363.000
										$n_{2 \text{ th}}$			
										$M_2$			
										c			
										$n_{2 \text{ Eck}}$	0.55	2848	412.500
										$n_{2 \text{ th}}$			

M ... [Nm]  
n ... [r/min]  
J ... [kgcm<sup>2</sup>]

P ... [kW]  
I ... [A]  
i [-]  
c [-]



# GST [Nm]

## GST□□-□S (MCS)

$M_{2GN} \leq 3107 \text{ Nm}$

GST14-2S				19FC14	19FC30	19JC14	19JC30	19PC14	19PC30
				...500	...500	...500	...500	...500	...500
i	$M_{2GN}$	$J_G$	$M_1$	27.00	21.00	40.00	29.00	51.00	32.00
			$n_1$	1425	3000	1425	3000	1350	3000
			$I_{M400}$	8.6	14.0	12.3	18.5	14.3	19.0
			$P_N$	4.00	6.60	6.00	9.10	7.20	10.00
			$J_M$	65.12	65.04	105.04	105.12	160.12	160.04
5.200	1201	168.00	$M_2$			192		248	153
			c			6.0		4.7	5.9
			$n_{2 \text{ Eck}}$			274		260	577
			$n_{2 \text{ th}}$			274		260	328
5.714	1320	161.00	$M_2$			210		272	168
			c			6.0		4.7	5.9
			$n_{2 \text{ Eck}}$			249		236	525
			$n_{2 \text{ th}}$			249		236	299
6.286	1364	141.00	$M_2$			232		300	186
			c			5.6		4.4	5.6
			$n_{2 \text{ Eck}}$			227		215	477
			$n_{2 \text{ th}}$			227		215	276
8.027	1467	100.00	$M_2$			300	216	386	240
			c			4.7	5.2	3.7	4.7
			$n_{2 \text{ Eck}}$			178	374	168	374
			$n_{2 \text{ th}}$			178	247	168	242
8.800	2033	139.00	$M_2$			324		419	259
			c			6.0		4.7	5.9
			$n_{2 \text{ Eck}}$			162		153	341
			$n_{2 \text{ th}}$			162		153	194
9.841	1546	75.10	$M_2$	245		370	267	476	296
			c	6.0		4.1	4.4	3.2	4.0
			$n_{2 \text{ Eck}}$	145		145	305	137	305
			$n_{2 \text{ th}}$	145		145	219	137	214
11.000	2386	119.00	$M_2$			407		525	326
			c			5.6		4.4	5.6
			$n_{2 \text{ Eck}}$			130		123	273
			$n_{2 \text{ th}}$			130		123	158
12.362	2260	89.00	$M_2$			461	333	595	369
			c			4.7	5.2	3.7	4.7
			$n_{2 \text{ Eck}}$			115	243	109	243
			$n_{2 \text{ th}}$			115	161	109	157
14.048	2568	86.60	$M_2$			524	378	676	420
			c			4.7	5.2	3.7	4.7
			$n_{2 \text{ Eck}}$			101	214	96	214
			$n_{2 \text{ th}}$			101	141	96	138
15.156	2381	67.60	$M_2$	377		570	409	733	453
			c	6.0		4.1	5.0	3.2	4.6
			$n_{2 \text{ Eck}}$	94		94	198	89	198
			$n_{2 \text{ th}}$	94		94	146	89	143
17.222	2705	66.00	$M_2$	428		647	464	833	515
			c	6.0		4.1	5.0	3.2	4.6
			$n_{2 \text{ Eck}}$	83		83	174	78	174
			$n_{2 \text{ th}}$	83		83	128	78	126
20.044	2507	45.80	$M_2$	505	389	760	546	976	605
			c	4.8	5.5	3.2	4.0	2.5	3.6
			$n_{2 \text{ Eck}}$	71	150	71	150	67	150
			$n_{2 \text{ th}}$	71	110	71	110	67	110
22.778	2849	44.90	$M_2$	573	442	864	621	1109	688
			c	4.8	5.5	3.2	4.0	2.5	3.6
			$n_{2 \text{ Eck}}$	63	132	63	132	59	132
			$n_{2 \text{ th}}$	63	97	63	97	59	97

M ... [Nm]  
 n ... [r/min]  
 J ... [kgcm<sup>2</sup>]

P ... [kW]  
 I ... [A]  
 i [-]  
 c [-]

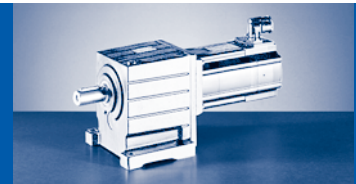

$M_{2GN} \leq 3107 \text{ Nm}$

GST14-2S				19FC14	19FC30	19JC14	19JC30	19PC14	19PC30
				...500	...500	...500	...500	...500	...500
i	$M_{2GN}$	$J_G$	$M_1$	27.00	21.00	40.00	29.00	51.00	32.00
			$n_1$	1425	3000	1425	3000	1350	3000
			$I_{M400}$	8.6	14.0	12.3	18.5	14.3	19.0
			$P_N$	4.00	6.60	6.00	9.10	7.20	10.00
			$J_M$	65.12	65.04	105.04	105.12	160.12	160.04
24.567	2627	33.20	$M_2$	623	481	936	674	1201	746
			c	4.1	4.7	2.8	3.4	2.2	3.1
			$n_{2Eck}$	58	122	58	122	55	122
			$n_{2th}$	58	90	58	90	55	90
27.917	2985	32.60	$M_2$	708	547	1064	766	1365	848
			c	4.1	4.7	2.8	3.4	2.2	3.1
			$n_{2Eck}$	51	108	51	108	48	108
			$n_{2th}$	51	79	51	79	48	79
32.267	2701	21.50	$M_2$	826	639	1237	892	1585	987
			c	3.2	3.7	2.2	2.7	1.7	2.4
			$n_{2Eck}$	44	93	44	93	42	93
			$n_{2th}$	44	69	44	69	42	69
36.667	3069	21.20	$M_2$	939	726	1406	1014	1801	1122
			c	3.2	3.7	2.2	2.7	1.7	2.4
			$n_{2Eck}$	39	82	39	82	37	82
			$n_{2th}$	39	60	39	60	37	60
39.160	2734	15.70	$M_2$	1008	781	1507	1088	1929	1203
			c	2.7	3.1	1.8	2.2	1.4	2.0
			$n_{2Eck}$	36	77	36	77	35	77
			$n_{2th}$	36	56	36	56	34	56
44.500	3107	15.50	$M_2$	1146	884	1713	1233	2193	1364
			c	2.7	3.4	1.8	2.5	1.4	2.3
			$n_{2Eck}$	32	67	32	67	30	67
			$n_{2th}$	32	50	32	50	30	50

M ... [Nm]  
n ... [r/min]  
J ... [kgcm<sup>2</sup>]

P ... [kW]  
I ... [A]  
i [-]  
c [-]

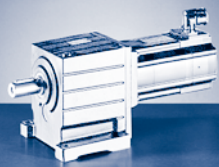

# GST [Nm]

## GST□□-□S (MCS)

$M_{2GN} \leq 5920 \text{ Nm}$

GST14-3S				12DC20	12DC41	12HC15	12HC30	12HC35	12LC20	12LC41	14DC15	14DC36	14HC15
				...500	...500	...500	...500	...500	...500	...500	...500	...500	...500
i	$M_{2GN}$	$J_G$	$M_1$	5.50	4.30	10.00	8.00	7.50	13.50	11.00	9.20	7.50	16.00
			$n_1$	1950	4050	1500	3000	3525	1950	4050	1500	3600	1500
			$I_{M230}$	5.2	8.8	7.6	10.5		11.8				
			$I_{M400}$	2.6	4.5	3.8		5.7	5.9	10.2	4.5	7.5	6.6
			$P_N$	1.10	1.80	1.60	2.50	2.80	2.80	4.70	1.45	2.80	2.50
			$J_M$	4.12	4.12	7.42	7.42	7.42	10.72	10.72	8.22	8.22	14.32
40.185	3459	24.40	$M_2$										585
			c										5.6
			$n_{2 \text{ Eck}}$										37
			$n_{2 \text{ th}}$										37
40.185	4476	24.40	$M_2$										
			c										
			$n_{2 \text{ Eck}}$										
			$n_{2 \text{ th}}$										
42.580	2052	18.30	$M_2$			390			534	433			
			c			5.0			3.7	4.2			
			$n_{2 \text{ Eck}}$			35			46	95			
			$n_{2 \text{ th}}$			35			46	84			
42.580	3211	18.30	$M_2$										624
			c										4.9
			$n_{2 \text{ Eck}}$										35
			$n_{2 \text{ th}}$										35
42.580	4262	18.30	$M_2$										
			c										
			$n_{2 \text{ Eck}}$										
			$n_{2 \text{ th}}$										
48.386	2332	18.10	$M_2$			443			606	492			
			c			5.0			3.7	4.2			
			$n_{2 \text{ Eck}}$			31			40	84			
			$n_{2 \text{ th}}$			31			40	74			
48.386	3649	18.10	$M_2$										709
			c										4.9
			$n_{2 \text{ Eck}}$										31
			$n_{2 \text{ th}}$										31
48.386	4843	18.10	$M_2$										
			c										
			$n_{2 \text{ Eck}}$										
			$n_{2 \text{ th}}$										
53.148	4574	20.50	$M_2$										773
			c										5.6
			$n_{2 \text{ Eck}}$										28
			$n_{2 \text{ th}}$										28
53.148	4779	20.50	$M_2$										
			c										
			$n_{2 \text{ Eck}}$										
			$n_{2 \text{ th}}$										
59.321	3840	13.20	$M_2$										876
			c										4.2
			$n_{2 \text{ Eck}}$										25
			$n_{2 \text{ th}}$										25
59.321	5267	13.20	$M_2$										
			c										
			$n_{2 \text{ Eck}}$										
			$n_{2 \text{ th}}$										
69.042	4470	11.50	$M_2$										1020
			c										4.2
			$n_{2 \text{ Eck}}$										22
			$n_{2 \text{ th}}$										22

$M \dots$  [Nm]  
 $n \dots$  [r/min]  
 $J \dots$  [kgcm<sup>2</sup>]

$P \dots$  [kW]  
 $I \dots$  [A]  
 $i \dots$  [-]  
 $c \dots$  [-]

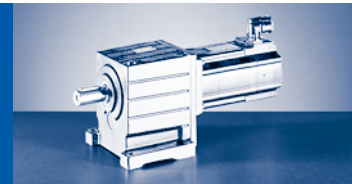

$M_{2GN} \leq 5920 \text{ Nm}$

14HC32	14LC15	14LC32	14PC14	14PC32	19FC14	19FC30	19JC14	19JC30	19PC14	19PC30	GST14-3S			
...500	...500	...500	...500	...500	...500	...500	...500	...500	...500	...500				
14.00	23.00	17.20	30.00	21.00	27.00	21.00	40.00	29.00	51.00	32.00	$M_1$	$J_G$	$M_{2GN}$	$i$
3225	1500	3225	1350	3225	1425	3000	1425	3000	1350	3000	$n_1$			
											$I_{M230}$			
11.9	9.7	15.0	10.8	15.6	8.6	14.0	12.3	18.5	14.3	19.0	$I_{M400}$			
4.70	3.60	5.80	4.20	7.10	4.00	6.60	6.00	9.10	7.20	10.00	$P_N$			
14.32	23.44	23.44	34.74	34.82	65.12	65.04	105.04	105.12	160.12	160.04	$J_M$			
511	856	636	1128	783							$M_2$			
5.7	3.9	4.6	3.0	3.8							c	24.40	3459	40.185
80	37	80	34	80							$n_{2 \text{ Eck}}$			
80	37	80	34	77							$n_{2 \text{ th}}$			
					1001	773	1505	1083	1932	1200	$M_2$			
					4.3	5.0	2.9	3.6	2.3	3.3	c	24.40	4476	40.185
					36	75	36	75	34	75	$n_{2 \text{ Eck}}$			
					35	55	35	55	34	55	$n_{2 \text{ th}}$			
											$M_2$			
											c	18.30	2052	42.580
											$n_{2 \text{ Eck}}$			
											$n_{2 \text{ th}}$			
543	912	674	1200	831							$M_2$			
5.5	3.4	4.5	2.6	3.7							c	18.30	3211	42.580
76	35	76	32	76							$n_{2 \text{ Eck}}$			
76	35	76	32	76							$n_{2 \text{ th}}$			
					1066	819	1600	1148	2052	1271	$M_2$			
					3.9	5.0	2.6	3.6	2.1	3.3	c	18.30	4262	42.580
					34	71	34	71	32	71	$n_{2 \text{ Eck}}$			
					33	52	33	52	32	52	$n_{2 \text{ th}}$			
											$M_2$			
											c	18.10	2332	48.386
											$n_{2 \text{ Eck}}$			
											$n_{2 \text{ th}}$			
617	1036	766	1364	944							$M_2$			
5.5	3.4	4.5	2.6	3.7							c	18.10	3649	48.386
67	31	67	28	67							$n_{2 \text{ Eck}}$			
67	31	67	28	67							$n_{2 \text{ th}}$			
					1211	931	1818	1304	2332	1445	$M_2$			
					3.9	5.0	2.6	3.6	2.1	3.3	c	18.10	4843	48.386
					30	62	30	62	28	62	$n_{2 \text{ Eck}}$			
					29	46	29	46	28	46	$n_{2 \text{ th}}$			
	1133	836	1492	1031							$M_2$			
	3.9	5.1	3.0	4.2							c	20.50	4574	53.148
	28	61	25	61							$n_{2 \text{ Eck}}$			
	28	61	25	59							$n_{2 \text{ th}}$			
					1336	1028	2003	1438	2568	1592	$M_2$			
					3.5	4.5	2.4	3.2	1.9	2.9	c	20.50	4779	53.148
					27	57	27	57	25	57	$n_{2 \text{ Eck}}$			
					27	42	27	42	25	42	$n_{2 \text{ th}}$			
763	1277	946	1678	1164							$M_2$			
4.7	3.0	3.9	2.3	3.2							c	13.20	3840	59.321
54	25	54	23	54							$n_{2 \text{ Eck}}$			
54	25	54	23	54							$n_{2 \text{ th}}$			
					1492	1148	2236	1606	2866	1778	$M_2$			
					3.4	4.4	2.3	3.2	1.8	2.9	c	13.20	5267	59.321
					24	51	24	51	23	51	$n_{2 \text{ Eck}}$			
					24	37	24	37	23	37	$n_{2 \text{ th}}$			
888	1487	1101	1953	1354							$M_2$			
4.7	3.0	3.9	2.3	3.2							c	11.50	4470	69.042
47	22	47	20	47							$n_{2 \text{ Eck}}$			
47	22	47	20	47							$n_{2 \text{ th}}$			

$M \dots$  [Nm]  
 $n \dots$  [r/min]  
 $J \dots$  [kgcm<sup>2</sup>]

$P \dots$  [kW]  
 $I \dots$  [A]  
 $i [-]$   
 $c [-]$

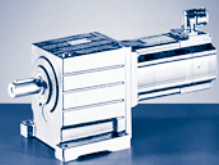

# GST [Nm]

## GST□□-□S (MCS)

$M_{2GN} \leq 5920 \text{ Nm}$

GST14-3S				12DC20	12DC41	12HC15	12HC30	12HC35	12LC20	12LC41	14DC15	14DC36	14HC15
				...500	...500	...500	...500	...500	...500	...500	...500	...500	...500
i	$M_{2GN}$	$J_G$	$M_1$	5.50	4.30	10.00	8.00	7.50	13.50	11.00	9.20	7.50	16.00
			$n_1$	1950	4050	1500	3000	3525	1950	4050	1500	3600	1500
			$I_{M230}$	5.2	8.8	7.6	10.5		11.8				
			$I_{M400}$	2.6	4.5	3.8		5.7	5.9	10.2	4.5	7.5	6.6
			$P_N$	1.10	1.80	1.60	2.50	2.80	2.80	4.70	1.45	2.80	2.50
			$J_M$	4.12	4.12	7.42	7.42	7.42	10.72	10.72	8.22	8.22	14.32
69.042	4917	11.50	$M_2$ c $n_{2 \text{ Eck}}$ $n_{2 \text{ th}}$										
78.457	5079	11.40	$M_2$ c $n_{2 \text{ Eck}}$ $n_{2 \text{ th}}$										1159 4.2 19 19
78.457	5587	11.40	$M_2$ c $n_{2 \text{ Eck}}$ $n_{2 \text{ th}}$										
93.541	3031	6.57	$M_2$ c $n_{2 \text{ Eck}}$ $n_{2 \text{ th}}$			872 3.4 16 16	691 4.2 32 32	647 4.3 38 38	1188 2.5 21 21	965 2.8 43 43			
93.541	4733	6.57	$M_2$ c $n_{2 \text{ Eck}}$ $n_{2 \text{ th}}$								782 5.8 16 16		1396 3.3 16 16
96.157	5882	10.40	$M_2$ c $n_{2 \text{ Eck}}$ $n_{2 \text{ th}}$										1424 4.0 16 16
106.296	3444	6.52	$M_2$ c $n_{2 \text{ Eck}}$ $n_{2 \text{ th}}$			990 3.4 14 14	785 4.2 28 28	736 4.3 33 33	1350 2.5 18 18	1097 2.8 38 38			
106.296	5378	6.52	$M_2$ c $n_{2 \text{ Eck}}$ $n_{2 \text{ th}}$								888 5.8 14 14		1586 3.3 14 14
130.278	4221	6.00	$M_2$ c $n_{2 \text{ Eck}}$ $n_{2 \text{ th}}$			1214 3.4 12 12	962 4.2 23 23	902 4.3 27 27	1654 2.5 15 15	1344 2.8 31 31			
130.278	5920	6.00	$M_2$ c $n_{2 \text{ Eck}}$ $n_{2 \text{ th}}$								1095 5.2 12 12	885 6.0 28 28	1951 3.0 12 12
139.211	3865	4.42	$M_2$ c $n_{2 \text{ Eck}}$ $n_{2 \text{ th}}$	699 5.3 14 14		1304 2.9 11 11	1035 3.6 22 22	970 3.7 25 25	1774 2.2 14 14	1442 2.4 29 29			
139.211	5736	4.42	$M_2$ c $n_{2 \text{ Eck}}$ $n_{2 \text{ th}}$								1177 4.7 11 11	952 5.4 26 26	2091 2.7 11 11
158.194	4392	4.40	$M_2$ c $n_{2 \text{ Eck}}$ $n_{2 \text{ th}}$	794 5.3 12 12		1482 2.9 10 9	1176 3.6 19 19	1102 3.7 22 22	2016 2.2 12 12	1639 2.4 26 26			

$M \dots$  [Nm]  
 $n \dots$  [r/min]  
 $J \dots$  [kgcm<sup>2</sup>]

$P \dots$  [kW]  
 $I \dots$  [A]  
 $i \dots$  [-]  
 $c \dots$  [-]

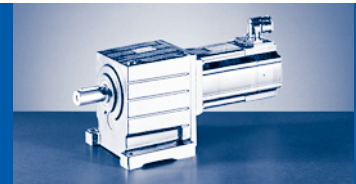

$M_{2GN} \leq 5920 \text{ Nm}$

14HC32	14LC15	14LC32	14PC14	14PC32	19FC14	19FC30	19JC14	19JC30	19PC14	19PC30	GST14-3S			
...500	...500	...500	...500	...500	...500	...500	...500	...500	...500	...500	$M_1$	$J_G$	$M_{2GN}$	i
14.00	23.00	17.20	30.00	21.00	27.00	21.00	40.00	29.00	51.00	32.00	$n_1$			
3225	1500	3225	1350	3225	1425	3000	1425	3000	1350	3000	$I_{M230}$			
11.9	9.7	15.0	10.8	15.6	8.6	14.0	12.3	18.5	14.3	19.0	$I_{M400}$			
4.70	3.60	5.80	4.20	7.10	4.00	6.60	6.00	9.10	7.20	10.00	$P_N$			
14.32	23.44	23.44	34.74	34.82	65.12	65.04	105.04	105.12	160.12	160.04	$J_M$			
					1749	1349	2615	1882	3349	2082	$M_2$			
					2.8	3.6	1.9	2.6	1.5	2.3	c	11.50	4917	69.042
					21	44	21	44	20	44	$n_{2 \text{ Eck}}$			
					21	32	21	32	20	32	$n_{2 \text{ th}}$			
1009	1689	1251	2220	1539							$M_2$			
4.7	3.0	3.9	2.3	3.2							c	11.40	5079	78.457
41	19	41	17	41							$n_{2 \text{ Eck}}$			
41	19	41	17	41							$n_{2 \text{ th}}$			
					1987	1533	2972	2139	3805	2366	$M_2$			
					2.8	3.6	1.9	2.6	1.5	2.3	c	11.40	5587	78.457
					18	38	18	38	17	38	$n_{2 \text{ Eck}}$			
					18	28	18	28	17	28	$n_{2 \text{ th}}$			
											$M_2$			
											c	6.57	3031	93.541
											$n_{2 \text{ Eck}}$			
											$n_{2 \text{ th}}$			
1216	2028	1505	2660	1849							$M_2$			
3.7	2.3	3.0	1.8	2.5							c	6.57	4733	93.541
35	16	35	14	35							$n_{2 \text{ Eck}}$			
34	16	34	14	34							$n_{2 \text{ th}}$			
1240	2074	1537	2724	1890	2446	1888	3653	2631	4674	2910	$M_2$			
4.5	2.8	3.6	2.1	3.0	2.4	3.1	1.6	2.2	1.3	2.0	c	10.40	5882	96.157
34	16	34	14	34	15	31	15	31	14	31	$n_{2 \text{ Eck}}$			
34	16	34	14	34	15	23	15	23	14	23	$n_{2 \text{ th}}$			
											$M_2$			
											c	6.52	3444	106.296
											$n_{2 \text{ Eck}}$			
											$n_{2 \text{ th}}$			
1382	2305	1711	3023	2101							$M_2$			
3.7	2.3	3.0	1.8	2.5							c	6.52	5378	106.296
30	14	30	13	30							$n_{2 \text{ Eck}}$			
30	14	30	13	30							$n_{2 \text{ th}}$			
											$M_2$			
											c	6.00	4221	130.278
											$n_{2 \text{ Eck}}$			
											$n_{2 \text{ th}}$			
1701	2832	2103	3712	2581							$M_2$			
3.3	2.1	2.7	1.6	2.2							c	6.00	5920	130.278
25	12	25	10	25							$n_{2 \text{ Eck}}$			
25	12	25	10	25							$n_{2 \text{ th}}$			
											$M_2$			
											c	4.42	3865	139.211
											$n_{2 \text{ Eck}}$			
											$n_{2 \text{ th}}$			
1823	3032	2254	3973	2764							$M_2$			
3.0	1.9	2.5	1.4	2.0							c	4.42	5736	139.211
23	11	23	10	23							$n_{2 \text{ Eck}}$			
23	11	23	10	23							$n_{2 \text{ th}}$			
											$M_2$			
											c	4.40	4392	158.194
											$n_{2 \text{ Eck}}$			
											$n_{2 \text{ th}}$			

$M \dots$  [Nm]  
 $n \dots$  [r/min]  
 $J \dots$  [kgcm<sup>2</sup>]

$P \dots$  [kW]  
 $I \dots$  [A]  
 $i [-]$   
 $c [-]$

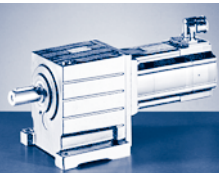

# GST [Nm]

## GST□□-□S (MCS)

$M_{2GN} \leq 5920 \text{ Nm}$

GST14-3S				12DC20	12DC41	12HC15	12HC30	12HC35	12LC20	12LC41	14DC15	14DC36	14HC15
				...500	...500	...500	...500	...500	...500	...500	...500	...500	...500
i	$M_{2GN}$	$J_G$	$M_1$	5.50	4.30	10.00	8.00	7.50	13.50	11.00	9.20	7.50	16.00
			$n_1$	1950	4050	1500	3000	3525	1950	4050	1500	3600	1500
			$I_{M230}$	5.2	8.8	7.6	10.5		11.8				
			$I_{M400}$	2.6	4.5	3.8		5.7	5.9	10.2	4.5	7.5	6.6
			$P_N$	1.10	1.80	1.60	2.50	2.80	2.80	4.70	1.45	2.80	2.50
			$J_M$	4.12	4.12	7.42	7.42	7.42	10.72	10.72	8.22	8.22	14.32
158.194	5920	4.40	$M_2$								1343	1087	2382
			c								4.3	4.9	2.5
			$n_{2 \text{ Eck}}$								10	23	10
			$n_{2 \text{ th}}$								9	23	9
171.111	5544	5.49	$M_2$			1594	1264	1184	2173	1765			
			c			3.4	4.2	4.3	2.5	2.8			
			$n_{2 \text{ Eck}}$			9	18	21	11	24			
			$n_{2 \text{ th}}$			9	18	21	11	24			
171.111	5920	5.49	$M_2$								1458	1181	2582
			c								3.9	4.5	2.3
			$n_{2 \text{ Eck}}$								9	21	9
			$n_{2 \text{ th}}$								9	21	9
204.722	4557	2.86	$M_2$	1040	807	1929	1534	1438	2621	2131			
			c	4.2	4.9	2.3	2.9	2.9	1.7	1.9			
			$n_{2 \text{ Eck}}$	10	20	7	15	17	10	20			
			$n_{2 \text{ th}}$	10	20	7	15	17	10	20			
204.722	5920	2.86	$M_2$								1757	1424	3101
			c								3.3	3.8	1.9
			$n_{2 \text{ Eck}}$								7	18	7
			$n_{2 \text{ th}}$								7	18	7
236.622	5267	2.65	$M_2$	1202	933	2230	1773	1662	3030	2464			
			c	4.2	4.9	2.3	2.9	2.9	1.7	1.9			
			$n_{2 \text{ Eck}}$	8	17	6	13	15	8	17			
			$n_{2 \text{ th}}$	8	17	6	13	15	8	17			
236.622	5779	2.65	$M_2$								2042	1657	3596
			c								2.8	3.2	1.6
			$n_{2 \text{ Eck}}$								6	15	6
			$n_{2 \text{ th}}$								6	15	6
248.458	4614	2.06	$M_2$	1271	988	2351	1871	1754	3191	2596			
			c	3.5	4.1	1.9	2.4	2.5	1.4	1.6			
			$n_{2 \text{ Eck}}$	8	16	6	12	14	8	16			
			$n_{2 \text{ th}}$	8	16	6	12	14	8	16			
248.458	5920	2.06	$M_2$								2145	1741	3777
			c								2.7	3.1	1.6
			$n_{2 \text{ Eck}}$								6	15	6
			$n_{2 \text{ th}}$								6	14	6
268.889	5920	2.65	$M_2$	1366	1060	2535	2015	1889	3443	2800	2327	1889	4093
			c	4.2	4.9	2.3	2.9	2.9	1.7	1.9	2.5	2.9	1.4
			$n_{2 \text{ Eck}}$	7	15	6	11	13	7	15	6	13	6
			$n_{2 \text{ th}}$	7	15	6	11	13	7	15	6	13	6
326.333	5920	1.92	$M_2$	1671	1299	3089	2459	2305	4192	3410	2837	2305	4980
			c	3.5	4.0	1.9	2.4	2.4	1.4	1.6	2.1	2.4	1.2
			$n_{2 \text{ Eck}}$	6	12	5	9	11	6	12	5	11	5
			$n_{2 \text{ th}}$	6	12	5	9	11	6	12	5	11	5
363.000	5401	2.45	$M_2$	1871	1456	3449	2748	2575	4676	3805			
			c	2.8	3.3	1.6	2.0	2.0	1.2	1.3			
			$n_{2 \text{ Eck}}$	5	11	4	8	10	5	11			
			$n_{2 \text{ th}}$	5	11	4	8	10	5	11			
412.500	5920	1.78	$M_2$	2129	1657	3921	3125	2929	5316	4326			
			c	2.7	3.2	1.5	1.9	1.9	1.1	1.2			
			$n_{2 \text{ Eck}}$	5	10	4	7	9	5	10			
			$n_{2 \text{ th}}$	5	10	4	7	9	5	10			

$M \dots$  [Nm]  
 $n \dots$  [r/min]  
 $J \dots$  [kgcm<sup>2</sup>]

$P \dots$  [kW]  
 $I \dots$  [A]  
 $i \dots$  [-]  
 $c \dots$  [-]

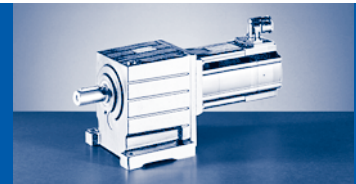

$M_{2GN} \leq 5920 \text{ Nm}$

14HC32	14LC15	14LC32	14PC14	14PC32	19FC14	19FC30	19JC14	19JC30	19PC14	19PC30	GST14-3S			
...500	...500	...500	...500	...500	...500	...500	...500	...500	...500	...500	$M_1$	$J_G$	$M_{2GN}$	i
14.00	23.00	17.20	30.00	21.00	27.00	21.00	40.00	29.00	51.00	32.00	$n_1$			
3225	1500	3225	1350	3225	1425	3000	1425	3000	1350	3000	$I_{M230}$			
11.9	9.7	15.0	10.8	15.6	8.6	14.0	12.3	18.5	14.3	19.0	$I_{M400}$			
4.70	3.60	5.80	4.20	7.10	4.00	6.60	6.00	9.10	7.20	10.00	$P_N$			
14.32	23.44	23.44	34.74	34.82	65.12	65.04	105.04	105.12	160.12	160.04	$J_M$			
2078	3452	2567	4521	3148							$M_2$			
2.7	1.7	2.2	1.3	1.8							c	4.40	5920	158.194
20	10	20	9	20							$n_{2\text{ Eck}}$			
20	9	20	9	20							$n_{2\text{ th}}$			
											$M_2$			
											c	5.49	5544	171.111
											$n_{2\text{ Eck}}$			
											$n_{2\text{ th}}$			
2253	3739	2782	4895	3410							$M_2$			
2.5	1.6	2.1	1.2	1.7							c	5.49	5920	171.111
19	9	19	8	19							$n_{2\text{ Eck}}$			
19	9	19	8	19							$n_{2\text{ th}}$			
											$M_2$			
											c	2.86	4557	204.722
											$n_{2\text{ Eck}}$			
											$n_{2\text{ th}}$			
2707	4485	3340	5869	4091							$M_2$			
2.1	1.3	1.7	1.0	1.4							c	2.86	5920	204.722
16	7	16	7	16							$n_{2\text{ Eck}}$			
16	7	16	7	16							$n_{2\text{ th}}$			
											$M_2$			
											c	2.65	5267	236.622
											$n_{2\text{ Eck}}$			
											$n_{2\text{ th}}$			
3140	5195	3871		4739							$M_2$			
1.8	1.1	1.5		1.2							c	2.65	5779	236.622
14	6	14		14							$n_{2\text{ Eck}}$			
14	6	14		14							$n_{2\text{ th}}$			
											$M_2$			
											c	2.06	4614	248.458
											$n_{2\text{ Eck}}$			
											$n_{2\text{ th}}$			
3299	5456	4066		4978							$M_2$			
1.7	1.1	1.4		1.2							c	2.06	5920	248.458
13	6	13		13							$n_{2\text{ Eck}}$			
13	6	13		13							$n_{2\text{ th}}$			
3575	5910	4406		5392							$M_2$			
1.6	1.0	1.3		1.1							c	2.65	5920	268.889
12	6	12		12							$n_{2\text{ Eck}}$			
12	6	12		12							$n_{2\text{ th}}$			
4351		5360									$M_2$			
1.3		1.1									c	1.92	5920	326.333
10		10									$n_{2\text{ Eck}}$			
10		10									$n_{2\text{ th}}$			
											$M_2$			
											c	2.45	5401	363.000
											$n_{2\text{ Eck}}$			
											$n_{2\text{ th}}$			
											$M_2$			
											c	1.78	5920	412.500
											$n_{2\text{ Eck}}$			
											$n_{2\text{ th}}$			

$M \dots$  [Nm]  
 $n \dots$  [r/min]  
 $J \dots$  [kgcm<sup>2</sup>]

$P \dots$  [kW]  
 $I \dots$  [A]  
 $i$  [-]  
 $c$  [-]

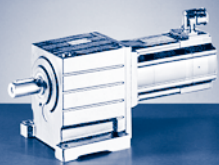

# GST [Nm]

## GST□□-□A (MCA)

$M_{2GN} \leq 25 \text{ Nm}$

GST04-1A				10IC40	13IC34	13IC41
				...500	...F10	...500
i	$M_{2GN}$	$J_G$	$M_1$			
			$n_1$	2.00	6.30	4.00
			$I_{M400}$	3950	3410	4050
			$P_N$	2.4	6.0	4.4
			$J_M$	0.80	2.20	1.70
			$M_2$	2.44	8.34	8.34
1.600	19	0.27	c	20	10	6
			$n_{2 \text{ Eck}}$	5.1	1.5	2.2
			$n_{2 \text{ th}}$	1023	2131	2531
				2439	1841	2159
2.048	23	0.19	$M_2$	4	13	8
			c	4.1	1.4	2.0
			$n_{2 \text{ Eck}}$	1929	1665	1978
			$n_{2 \text{ th}}$	1929	1623	1966
2.240	25	0.17	$M_2$	4	14	9
			c	4.1	1.4	2.0
			$n_{2 \text{ Eck}}$	1763	1522	1808
			$n_{2 \text{ th}}$	1763	1522	1808
2.857	25	0.13	$M_2$	6	18	11
			c	3.2	1.1	1.6
			$n_{2 \text{ Eck}}$	1383	1194	1418
			$n_{2 \text{ th}}$	1383	1194	1418
3.500	25	0.10	$M_2$	7		14
			c	2.6		1.3
			$n_{2 \text{ Eck}}$	1129		1157
			$n_{2 \text{ th}}$	1129		1157
4.400	25	0.07	$M_2$	9		
			c	2.1		
			$n_{2 \text{ Eck}}$	898		
			$n_{2 \text{ th}}$	898		
5.667	25	0.05	$M_2$	11		
			c	1.6		
			$n_{2 \text{ Eck}}$	697		
			$n_{2 \text{ th}}$	697		

M ... [Nm]  
 n ... [r/min]  
 J ... [kgcm<sup>2</sup>]

P ... [kW]  
 I ... [A]  
 i [-]  
 c [-]

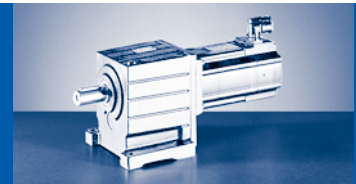

$M_{2GN} \leq 71 \text{ Nm}$

GST04-2A				10IC40	13IC34	13IC41
				...500	...F10	...500
i	$M_{2GN}$	$J_G$	$M_1$			
			$n_1$	2.00	6.30	4.00
			$I_{M400}$	3950	3410	4050
			$P_N$	2.4	6.0	4.4
			$J_M$	0.80	2.20	1.70
			$M_2$	2.44	8.34	8.34
2.956	39	0.34	c	6	18	11
			$n_{2 \text{ Eck}}$	4.9	1.7	2.5
			$n_{2 \text{ th}}$	1337	1154	1370
				1218	923	1066
3.333	42	0.32	$M_2$	6	20	13
			c	4.7	1.6	2.3
			$n_{2 \text{ Eck}}$	1185	1023	1215
			$n_{2 \text{ th}}$	1070	795	935
4.053	45	0.31	$M_2$	8	25	16
			c	4.1	1.4	2.1
			$n_{2 \text{ Eck}}$	975	841	999
			$n_{2 \text{ th}}$	953	707	842
4.571	48	0.30	$M_2$	9	28	18
			c	3.9	1.3	1.9
			$n_{2 \text{ Eck}}$	864	746	886
			$n_{2 \text{ th}}$	837	612	736
5.187	50	0.22	$M_2$	10	32	20
			c	3.6	1.2	1.8
			$n_{2 \text{ Eck}}$	762	657	781
			$n_{2 \text{ th}}$	761	604	733
5.850	53	0.22	$M_2$	11	36	23
			c	3.4	1.1	1.7
			$n_{2 \text{ Eck}}$	675	583	692
			$n_{2 \text{ th}}$	675	523	630
6.400	55	0.19	$M_2$	12	39	25
			c	3.2	1.1	1.6
			$n_{2 \text{ Eck}}$	617	533	633
			$n_{2 \text{ th}}$	617	492	585
7.040	57	0.26	$M_2$	13	43	27
			c	3.0	1.0	1.5
			$n_{2 \text{ Eck}}$	561	484	575
			$n_{2 \text{ th}}$	520	359	421
8.000	59	0.26	$M_2$	15		31
			c	2.7		1.4
			$n_{2 \text{ Eck}}$	494		506
			$n_{2 \text{ th}}$	450		356
9.010	63	0.19	$M_2$	17		35
			c	2.6		1.3
			$n_{2 \text{ Eck}}$	438		450
			$n_{2 \text{ th}}$	438		359
9.856	65	0.17	$M_2$	19		38
			c	2.5		1.2
			$n_{2 \text{ Eck}}$	401		411
			$n_{2 \text{ th}}$	401		336
11.200	60	0.17	$M_2$	22		
			c	2.0		
			$n_{2 \text{ Eck}}$	353		
			$n_{2 \text{ th}}$	353		
12.571	69	0.13	$M_2$	24		49
			c	2.1		1.0
			$n_{2 \text{ Eck}}$	314		322
			$n_{2 \text{ th}}$	314		286

M ... [Nm]  
n ... [r/min]  
J ... [kgcm<sup>2</sup>]

P ... [kW]  
I ... [A]  
i [-]  
c [-]

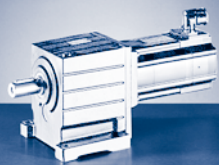

# GST [Nm]

## GST□□-□A (MCA)

$M_{2GN} \leq 71 \text{ Nm}$

GST04-2A				10IC40	13IC34	13IC41
				...500	...F10	...500
i	$M_{2GN}$	$J_G$	$M_1$			
			$n_1$	3950	3410	4050
			$I_{M400}$	2.4	6.0	4.4
			$P_N$	0.80	2.20	1.70
			$J_M$	2.44	8.34	8.34
14.286	61	0.12	$M_2$	28		
			c	1.6		
			$n_{2 \text{ Eck}}$	277		
			$n_{2 \text{ th}}$	277		
15.400	70	0.10	$M_2$	30		
			c	1.9		
			$n_{2 \text{ Eck}}$	257		
			$n_{2 \text{ th}}$	256		
17.500	62	0.10	$M_2$	34		
			c	1.5		
			$n_{2 \text{ Eck}}$	226		
			$n_{2 \text{ th}}$	226		
19.360	70	0.06	$M_2$	37		
			c	1.5		
			$n_{2 \text{ Eck}}$	204		
			$n_{2 \text{ th}}$	204		
22.000	62	0.06	$M_2$	43		
			c	1.2		
			$n_{2 \text{ Eck}}$	180		
			$n_{2 \text{ th}}$	180		
24.933	71	0.04	$M_2$	48		
			c	1.2		
			$n_{2 \text{ Eck}}$	158		
			$n_{2 \text{ th}}$	158		

M ... [Nm]  
 n ... [r/min]  
 J ... [kgcm<sup>2</sup>]

P ... [kW]  
 I ... [A]  
 i [-]  
 c [-]

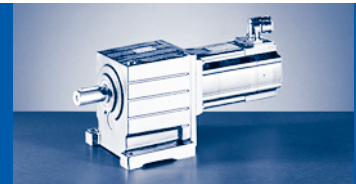

$M_{2GN} \leq 54 \text{ Nm}$

GST05-1A				10IC40	13IC34	13IC41	14LC16	14LC20	14LC35	14LC41
				...S00	...F10	...S00	...F10	...S00	...F10	...S00
i	$M_{2GN}$	$J_G$	$M_1$							
			$n_1$	3950	3410	4050	1635	2000	3455	4100
			$I_{M400}$	2.4	6.0	4.4	4.8	3.3	9.1	5.8
			$P_N$	0.80	2.20	1.70	2.10	1.40	3.90	2.30
			$J_M$	2.44	8.34	8.34	19.32	19.24	19.24	19.24
1.600	45	0.76	$M_2$		10	6	19	10	17	8
			c		3.4	5.1	2.3	3.9	2.0	3.8
			$n_{2 \text{ Eck}}$		2131	2531	1022	1250	2159	2563
			$n_{2 \text{ th}}$		2056	2215	1022	1250	1847	2093
2.048	53	0.55	$M_2$		12	8	24	13	22	11
			c		3.1	4.7	2.1	3.5	1.8	3.5
			$n_{2 \text{ Eck}}$		1665	1978	799	977	1687	2002
			$n_{2 \text{ th}}$		1665	1856	798	977	1525	1753
2.240	53	0.48	$M_2$		14	9	26	14	24	12
			c		2.9	4.3	2.0	3.3	1.7	3.2
			$n_{2 \text{ Eck}}$		1522	1808	730	893	1542	1830
			$n_{2 \text{ th}}$		1522	1733	730	893	1397	1603
2.857	53	0.35	$M_2$		18	11	34	19	30	15
			c		2.3	3.4	1.5	2.6	1.3	2.5
			$n_{2 \text{ Eck}}$		1194	1418	572	700	1209	1435
			$n_{2 \text{ th}}$		1194	1418	572	700	1157	1257
3.500	54	0.27	$M_2$	7	22	14	41	23	37	18
			c	5.7	1.9	2.8	1.3	2.1	1.1	2.1
			$n_{2 \text{ Eck}}$	1129	974	1157	467	571	987	1171
			$n_{2 \text{ th}}$	1129	974	1157	467	571	987	1026
4.556	54	0.18	$M_2$	9	28	18				
			c	4.4	1.5	2.2				
			$n_{2 \text{ Eck}}$	867	749	889				
			$n_{2 \text{ th}}$	867	749	889				
5.667	54	0.13	$M_2$	11	35	22				
			c	3.5	1.2	1.7				
			$n_{2 \text{ Eck}}$	697	602	715				
			$n_{2 \text{ th}}$	697	602	715				
7.333	47	0.06	$M_2$	14						
			c	2.3						
			$n_{2 \text{ Eck}}$	539						
			$n_{2 \text{ th}}$	539						
8.900	42	0.06	$M_2$	17						
			c	1.7						
			$n_{2 \text{ Eck}}$	444						
			$n_{2 \text{ th}}$	444						

$M \dots$  [Nm]  
 $n \dots$  [r/min]  
 $J \dots$  [kgcm<sup>2</sup>]

$P \dots$  [kW]  
 $I \dots$  [A]  
 $i$  [-]  
 $c$  [-]

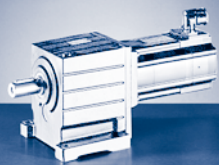

# GST [Nm]

## GST□□-□A (MCA)

$M_{2GN} \leq 165 \text{ Nm}$

GST05-2A				10IC40	13IC34	13IC41	14LC16	14LC20	14LC35	14LC41
				...S00	...F10	...S00	...F10	...S00	...F10	...S00
i	$M_{2GN}$	$J_G$	$M_1$	2.00	6.30	4.00	12.00	6.70	10.80	5.40
			$n_1$	3950	3410	4050	1635	2000	3455	4100
			$I_{M400}$	2.4	6.0	4.4	4.8	3.3	9.1	5.8
			$P_N$	0.80	2.20	1.70	2.10	1.40	3.90	2.30
			$J_M$	2.44	8.34	8.34	19.32	19.24	19.24	19.24
2.956	63	0.99	$M_2$		18	11	34	19	31	15
			c		2.7	4.0	1.8	3.0	1.5	2.9
			$n_{2 \text{ Eck}}$		1154	1370	553	677	1169	1387
			$n_{2 \text{ th}}$		899	975	553	677	735	917
3.333	78	0.94	$M_2$		20	12	38	21	35	17
			c		2.9	4.3	2.0	3.3	1.7	3.2
			$n_{2 \text{ Eck}}$		1023	1215	491	600	1037	1230
			$n_{2 \text{ th}}$		813	880	491	600	684	828
4.053	81	0.90	$M_2$		24	15	47	26	42	21
			c		2.5	3.7	1.7	2.8	1.5	2.7
			$n_{2 \text{ Eck}}$		841	999	403	493	852	1012
			$n_{2 \text{ th}}$		762	824	403	493	611	776
4.571	91	0.86	$M_2$		28	17	53	29	48	24
			c		2.5	3.7	1.7	2.8	1.4	2.7
			$n_{2 \text{ Eck}}$		746	886	358	438	756	897
			$n_{2 \text{ th}}$		675	730	358	438	541	688
5.187	90	0.64	$M_2$		31	20	60	33	54	27
			c		2.2	3.2	1.5	2.4	1.3	2.4
			$n_{2 \text{ Eck}}$		657	781	315	386	666	790
			$n_{2 \text{ th}}$		637	686	315	386	504	649
5.850	101	0.61	$M_2$		35	22	68	37	61	30
			c		2.2	3.2	1.5	2.4	1.3	2.4
			$n_{2 \text{ Eck}}$		583	692	280	342	591	701
			$n_{2 \text{ th}}$		565	608	279	342	447	575
6.400	105	0.53	$M_2$		39	24	74	41	67	33
			c		2.0	3.0	1.4	2.3	1.2	2.2
			$n_{2 \text{ Eck}}$		533	633	256	313	540	641
			$n_{2 \text{ th}}$		531	571	255	313	419	541
7.238	108	0.40	$M_2$	13	44	28	84	47	76	38
			c	5.6	1.9	2.8	1.3	2.1	1.1	2.0
			$n_{2 \text{ Eck}}$	546	471	560	226	276	477	567
			$n_{2 \text{ th}}$	546	471	560	226	276	419	496
8.163	115	0.39	$M_2$	15	50	31	95	53	86	42
			c	5.3	1.8	2.6	1.2	2.0	1.0	1.9
			$n_{2 \text{ Eck}}$	484	418	496	200	245	423	502
			$n_{2 \text{ th}}$	484	418	496	200	245	363	440
9.010	119	0.54	$M_2$	17	55	34	105	58		47
			c	4.9	1.6	2.4	1.1	1.8		1.8
			$n_{2 \text{ Eck}}$	438	379	450	182	222		455
			$n_{2 \text{ th}}$	426	328	376	181	222		344
10.000	124	0.30	$M_2$	19	61	38	116	65		52
			c	4.6	1.6	2.3	1.0	1.7		1.7
			$n_{2 \text{ Eck}}$	395	341	405	164	200		410
			$n_{2 \text{ th}}$	395	341	405	164	200		359
11.200	128	0.46	$M_2$	21	68	43		72		58
			c	4.3	1.4	2.1		1.6		1.6
			$n_{2 \text{ Eck}}$	353	305	362		179		366
			$n_{2 \text{ th}}$	346	258	306		179		269
13.016	137	0.18	$M_2$	24	79	50				
			c	3.9	1.3	2.0				
			$n_{2 \text{ Eck}}$	304	262	311				
			$n_{2 \text{ th}}$	303	262	311				

$M \dots$  [Nm]  
 $n \dots$  [r/min]  
 $J \dots$  [kgcm<sup>2</sup>]

$P \dots$  [kW]  
 $I \dots$  [A]  
 $i$  [-]  
 $c$  [-]

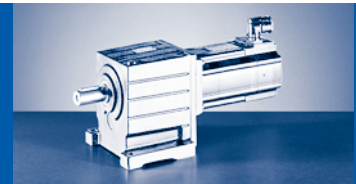

$M_{2GN} \leq 165 \text{ Nm}$

GST05-2A				10IC40	13IC34	13IC41	14LC16	14LC20	14LC35	14LC41
				...500	...F10	...S00	...F10	...S00	...F10	...500
i	$M_{2GN}$	$J_G$	$M_1$							
			$n_1$	3950	3410	4050	1635	2000	3455	4100
			$I_{M400}$	2.4	6.0	4.4	4.8	3.3	9.1	5.8
			$P_N$	0.80	2.20	1.70	2.10	1.40	3.90	2.30
			$J_M$	2.44	8.34	8.34	19.32	19.24	19.24	19.24
14.356	140	0.13	$M_2$	27	88	55				
			c	3.6	1.2	1.8				
			$n_{2 \text{ Eck}}$	275	238	282				
			$n_{2 \text{ th}}$	275	238	282				
16.190	148	0.13	$M_2$	30	99	62				
			c	3.9	1.3	1.9				
			$n_{2 \text{ Eck}}$	244	211	250				
			$n_{2 \text{ th}}$	244	211	250				
17.500	142	0.27	$M_2$	33	107	67		113		91
			c	3.4	1.2	1.7		1.3		1.3
			$n_{2 \text{ Eck}}$	226	195	231		114		234
			$n_{2 \text{ th}}$	226	195	231		114		205
20.044	159	0.16	$M_2$	38	122	77				
			c	3.4	1.1	1.7				
			$n_{2 \text{ Eck}}$	197	170	202				
			$n_{2 \text{ th}}$	197	170	202				
22.778	144	0.16	$M_2$	43		88				
			c	2.7		1.3				
			$n_{2 \text{ Eck}}$	173		178				
			$n_{2 \text{ th}}$	173		178				
24.933	162	0.12	$M_2$	48		96				
			c	2.8		1.4				
			$n_{2 \text{ Eck}}$	158		162				
			$n_{2 \text{ th}}$	158		162				
28.333	147	0.12	$M_2$	54		110				
			c	2.2		1.1				
			$n_{2 \text{ Eck}}$	139		143				
			$n_{2 \text{ th}}$	139		143				
32.267	164	0.08	$M_2$	62						
			c	2.2						
			$n_{2 \text{ Eck}}$	122						
			$n_{2 \text{ th}}$	122						
36.667	148	0.08	$M_2$	71						
			c	1.7						
			$n_{2 \text{ Eck}}$	108						
			$n_{2 \text{ th}}$	108						
39.160	165	0.06	$M_2$	75						
			c	1.8						
			$n_{2 \text{ Eck}}$	101						
			$n_{2 \text{ th}}$	101						
44.500	149	0.06	$M_2$	86						
			c	1.6						
			$n_{2 \text{ Eck}}$	89						
			$n_{2 \text{ th}}$	89						

$M \dots$  [Nm]  
 $n \dots$  [r/min]  
 $J \dots$  [kgcm<sup>2</sup>]

$P \dots$  [kW]  
 $I \dots$  [A]  
 $i$  [-]  
 $c$  [-]

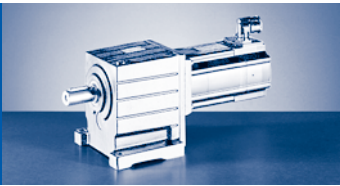

# GST [Nm]

## GST□□-□A (MCA)

$M_{2GN} \leq 167 \text{ Nm}$

GST05-3A				10IC40
				...500
i	$M_{2GN}$	$J_G$	$M_1$	
			$n_1$	2.00
			$I_{M400}$	3950
			$P_N$	-
			$J_M$	0.80
			$M_2$	2.44
			c	69
36.267	134	0.20	$n_{2Eck}$	1.6
			$n_{2th}$	109
			$M_2$	109
			c	88
46.259	145	0.14	$n_{2Eck}$	1.5
			$n_{2th}$	85
			$M_2$	85
			c	108
56.667	155	0.11	$n_{2Eck}$	1.3
			$n_{2th}$	70
			$M_2$	70
			c	121
63.467	146	0.19	$n_{2Eck}$	1.1
			$n_{2th}$	62
			$M_2$	62
			c	136
71.238	167	0.07	$n_{2Eck}$	1.1
			$n_{2th}$	56
				55

M ... [Nm]  
 n ... [r/min]  
 J ... [kgcm<sup>2</sup>]

P ... [kW]  
 I ... [A]  
 i [-]  
 c [-]

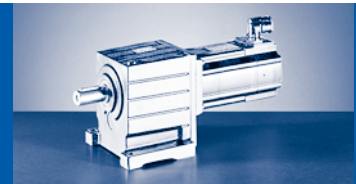

$M_{2GN} \leq 105 \text{ Nm}$

GST06-1A				10IC40	13IC34	13IC41	14LC16	14LC20	14LC35	14LC41	17NC17	17NC23	17NC35	17NC41
				...S00	...F10	...S00	...F10	...S00	...F10	...S00	...F10	...S00	...F10	...S00
i	$M_{2GN}$	$J_G$	$M_1$	2.00	6.30	4.00	12.00	6.70	10.80	5.40	21.50	10.80	19.00	9.50
			$n_1$	3950	3410	4050	1635	2000	3455	4100	1680	2300	3480	4110
			$I_{M400}$	2.4	6.0	4.4	4.8	3.3	9.1	5.8	8.5	5.5	15.8	10.2
			$P_N$	0.80	2.20	1.70	2.10	1.40	3.90	2.30	3.80	2.60	6.90	4.10
			$J_M$	2.44	8.34	8.34	19.32	19.24	19.24	19.24	36.04	36.04	36.04	36.04
1.600	61	2.01	$M_2$				18	10	17	8	34	17	30	15
			c				3.2	5.3	2.7	5.2	1.8	3.1	1.6	2.9
			$n_{2 \text{ Eck}}$				1022	1250	2159	2563	1050	1438	2175	2569
			$n_{2 \text{ th}}$				1022	1250	1635	1862	1050	1438	1325	1660
2.048	72	1.46	$M_2$		12		24	13	21	10	43	21	38	19
			c		4.3		2.9	4.9	2.5	4.8	1.6	2.9	1.4	2.7
			$n_{2 \text{ Eck}}$		1665		799	977	1687	2002	821	1123	1700	2007
			$n_{2 \text{ th}}$		1628		798	977	1459	1657	820	1123	1148	1481
2.240	79	1.27	$M_2$		13		26	14	23	11	47	23	42	21
			c		4.3		2.9	4.8	2.5	4.7	1.6	2.9	1.4	2.7
			$n_{2 \text{ Eck}}$		1522		730	893	1542	1830	750	1027	1554	1835
			$n_{2 \text{ th}}$		1522		730	893	1379	1561	750	1027	1093	1389
2.857	92	0.97	$M_2$		17	11	33	18	30	15	60	30	53	26
			c		4.0	5.9	2.7	4.5	2.3	4.4	1.5	2.6	1.3	2.5
			$n_{2 \text{ Eck}}$		1194	1418	572	700	1209	1435	588	805	1218	1439
			$n_{2 \text{ th}}$		1194	1395	572	700	1184	1257	588	805	944	1089
3.500	105	0.74	$M_2$		21	13	41	22	37	18	74	37	65	32
			c		3.7	5.5	2.5	4.1	2.1	4.0	1.4	2.4	1.2	2.3
			$n_{2 \text{ Eck}}$		974	1157	467	571	987	1171	480	657	994	1174
			$n_{2 \text{ th}}$		974	1157	467	571	987	1026	480	657	861	889
4.556	105	0.48	$M_2$		28	17	53	29	48	24				
			c		2.8	4.2	1.9	3.2	1.6	3.1				
			$n_{2 \text{ Eck}}$		749	889	359	439	758	900				
			$n_{2 \text{ th}}$		749	889	359	439	758	788				
5.667	82	0.36	$M_2$	11										
			c	5.3										
			$n_{2 \text{ Eck}}$	697										
			$n_{2 \text{ th}}$	697										
5.667	105	0.36	$M_2$		35	22	67	37	60	30				
			c		2.3	3.4	1.5	2.6	1.3	2.5				
			$n_{2 \text{ Eck}}$		602	715	289	353	610	724				
			$n_{2 \text{ th}}$		602	715	289	353	610	634				
7.333	95	0.23	$M_2$	14										
			c	4.8										
			$n_{2 \text{ Eck}}$	539										
			$n_{2 \text{ th}}$	539										
7.333	100	0.23	$M_2$		45	28								
			c		1.7	2.5								
			$n_{2 \text{ Eck}}$		465	552								
			$n_{2 \text{ th}}$		465	552								
8.900	85	0.17	$M_2$	17	55	35								
			c	3.5	1.2	1.8								
			$n_{2 \text{ Eck}}$	444	383	455								
			$n_{2 \text{ th}}$	444	383	455								
11.250	63	0.11	$M_2$	22										
			c	2.1										
			$n_{2 \text{ Eck}}$	351										
			$n_{2 \text{ th}}$	351										

$M \dots$  [Nm]  
 $n \dots$  [r/min]  
 $J \dots$  [kgcm<sup>2</sup>]

$P \dots$  [kW]  
 $I \dots$  [A]  
 $i$  [-]  
 $c$  [-]

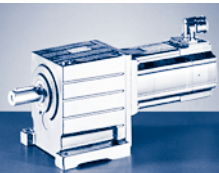

# GST [Nm]

## GST□□-□A (MCA)

$M_{2GN} \leq 368 \text{ Nm}$

GST06-2A				10IC40	13IC34	13IC41	14LC16	14LC20	14LC35	14LC41	17NC17	17NC23	17NC35	17NC41	
				...S00	...F10	...S00	...F10	...S00	...F10	...S00	...F10	...S00	...F10	...S00	
i	$M_{2GN}$	$J_G$	$M_1$	2.00	6.30	4.00	12.00	6.70	10.80	5.40	21.50	10.80	19.00	9.50	
			$n_1$	3950	3410	4050	1635	2000	3455	4100	1680	2300	3480	4110	
			$I_{M400}$	2.4	6.0	4.4	4.8	3.3	9.1	5.8	8.5	5.5	15.8	10.2	
			$P_N$	0.80	2.20	1.70	2.10	1.40	3.90	2.30	3.80	2.60	6.90	4.10	
			$J_M$	2.44	8.34	8.34	19.32	19.24	19.24	19.24	36.04	36.04	36.04	36.04	
3.033	166	2.72	$M_2$				34		31		62	31	55	27	
			c				4.6		4.0		2.5	4.5	2.3	4.3	
			$n_{2 \text{ Eck}}$				539		1139		554	758	1147	1355	
			$n_{2 \text{ th}}$				539		803		554	758	708	815	
3.333	174	2.61	$M_2$				37		34		69	34	61	30	
			c				4.4		3.8		2.4	4.3	2.1	4.1	
			$n_{2 \text{ Eck}}$				491		1037		504	690	1044	1233	
			$n_{2 \text{ th}}$				491		724		504	690	637	734	
4.160	191	2.51	$M_2$				47		43		86	42	76	37	
			c				3.8		3.3		2.1	3.8	1.9	3.6	
			$n_{2 \text{ Eck}}$				393		831		404	553	837	988	
			$n_{2 \text{ th}}$				393		656		404	553	569	665	
4.571	200	2.41	$M_2$				52		47	23	94	47	84	41	
			c				3.7		3.2	6.0	2.0	3.6	1.8	3.4	
			$n_{2 \text{ Eck}}$				358		756	897	368	503	761	899	
			$n_{2 \text{ th}}$				358		590	670	368	503	503	599	
5.324	207	1.76	$M_2$		31		61	33	55	27	110	55	98	48	
			c		4.9		3.3	5.4	2.8	5.3	1.8	3.2	1.6	3.0	
			$n_{2 \text{ Eck}}$		641		307	376	649	770	316	432	654	772	
			$n_{2 \text{ th}}$		640		307	376	574	651	316	432	470	583	
5.850	222	1.71	$M_2$		34		67	36	60	29	121	60	107	53	
			c		4.7		3.2	5.3	2.7	5.2	1.8	3.1	1.6	2.9	
			$n_{2 \text{ Eck}}$		583		280	342	591	701	287	393	595	703	
			$n_{2 \text{ th}}$		579		279	342	520	589	287	393	421	527	
6.400	229	1.47	$M_2$		38		73	40	66	32	133	66	117	58	
			c		4.5		3.0	5.0	2.6	4.9	1.7	3.0	1.5	2.8	
			$n_{2 \text{ Eck}}$		533		256	313	540	641	263	359	544	642	
			$n_{2 \text{ th}}$		533		255	313	487	550	263	359	390	486	
7.040	236	2.07	$M_2$				80	44	73	36	146	72	129	64	
			c				2.8	4.7	2.4	4.6	1.6	2.8	1.4	2.6	
			$n_{2 \text{ Eck}}$				232	284	491	582	239	327	494	584	
			$n_{2 \text{ th}}$				232	284	362	414	239	327	283	368	
8.163	252	1.06	$M_2$		48	30	94	51	84	41	170	84	150	74	
			c		3.8	5.7	2.6	4.3	2.2	4.2	1.4	2.6	1.3	2.4	
			$n_{2 \text{ Eck}}$		418	496	200	245	423	502	206	282	426	504	
			$n_{2 \text{ th}}$		418	486	200	245	412	440	206	282	326	381	
9.010	261	1.50	$M_2$		54	33	103	57	93	46	187	93	166	82	
			c		3.6	5.4	2.4	4.1	2.1	4.0	1.3	2.4	1.2	2.3	
			$n_{2 \text{ Eck}}$		379	450	182	222	384	455	187	255	386	456	
			$n_{2 \text{ th}}$		357	385	181	222	318	364	186	255	237	323	
10.000	269	0.82	$M_2$		60	37	115	63	104	51	208	103	184	91	
			c		3.4	5.0	2.3	3.8	2.0	3.7	1.2	2.2	1.1	2.1	
			$n_{2 \text{ Eck}}$		341	405	164	200	346	410	168	230	348	411	
			$n_{2 \text{ th}}$		341	405	164	200	346	359	168	230	289	311	
11.200	280	1.26	$M_2$		67	42	129	71	116	57	233	116	206	102	
			c		3.1	4.6	2.1	3.5	1.8	3.4	1.2	2.1	1.0	1.9	
			$n_{2 \text{ Eck}}$		305	362	146	179	309	366	150	205	311	367	
			$n_{2 \text{ th}}$		289	311	146	179	250	294	150	205	188	260	
12.571	295	0.96	$M_2$		75	47	145	80	131	64	262	130		115	
			c		2.9	4.3	2.0	3.3	1.7	3.2	1.1	1.9		1.8	
			$n_{2 \text{ Eck}}$		271	322	130	159	275	326	134	183		327	
			$n_{2 \text{ th}}$		271	301	130	159	242	286	134	183		247	

$M \dots$  [Nm]  
 $n \dots$  [r/min]  
 $J \dots$  [kgcm<sup>2</sup>]

$P \dots$  [kW]  
 $I \dots$  [A]  
 $i$  [-]  
 $c$  [-]

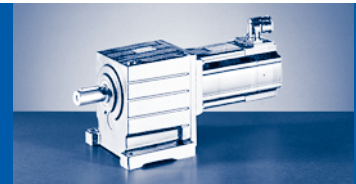

$M_{2GN} \leq 368 \text{ Nm}$

GST06-2A				10IC40	13IC34	13IC41	14LC16	14LC20	14LC35	14LC41	17NC17	17NC23	17NC35	17NC41
				...S00	...F10	...S00	...F10	...S00	...F10	...S00	...F10	...S00	...F10	...S00
i	$M_{2GN}$	$J_G$	$M_1$	2.00	6.30	4.00	12.00	6.70	10.80	5.40	21.50	10.80	19.00	9.50
			$n_1$	3950	3410	4050	1635	2000	3455	4100	1680	2300	3480	4110
			$I_{M400}$	2.4	6.0	4.4	4.8	3.3	9.1	5.8	8.5	5.5	15.8	10.2
			$P_N$	0.80	2.20	1.70	2.10	1.40	3.90	2.30	3.80	2.60	6.90	4.10
			$J_M$	2.44	8.34	8.34	19.32	19.24	19.24	19.24	36.04	36.04	36.04	36.04
14.286	307	0.93	$M_2$		86	54	165	91	149	73		148		131
			c		2.7	4.0	1.8	3.0	1.6	2.9		1.8		1.7
			$n_{2 \text{ Eck}}$		239	284	115	140	242	287		161		288
			$n_{2 \text{ th}}$		239	261	114	140	204	248		161		211
15.400	318	0.75	$M_2$		92	58	178	98	160	79		160		141
			c		2.9	4.3	1.8	3.2	1.7	3.2		1.9		1.8
			$n_{2 \text{ Eck}}$		221	263	106	130	224	266		149		267
			$n_{2 \text{ th}}$		221	263	106	130	224	233		149		202
17.500	313	0.73	$M_2$		105	66	203	112	182	90		182		160
			c		2.5	3.8	1.5	2.8	1.5	2.8		1.7		1.6
			$n_{2 \text{ Eck}}$		195	231	93	114	197	234		131		235
			$n_{2 \text{ th}}$		195	231	93	114	189	205		131		178
20.044	350	0.46	$M_2$		121	76	232	128	209	103				
			c		2.5	3.7	1.5	2.7	1.4	2.7				
			$n_{2 \text{ Eck}}$		170	202	82	100	172	205				
			$n_{2 \text{ th}}$		170	202	82	100	172	179				
22.778	315	0.45	$M_2$	42	138	87	265	146	238	118				
			c	5.9	2.0	2.9	1.2	2.1	1.1	2.2				
			$n_{2 \text{ Eck}}$	173	150	178	72	88	152	180				
			$n_{2 \text{ th}}$	173	150	178	72	88	152	158				
24.933	360	0.33	$M_2$		151	95	290	160	261	129				
			c		2.0	3.0	1.2	2.2	1.2	2.2				
			$n_{2 \text{ Eck}}$		137	162	66	80	139	164				
			$n_{2 \text{ th}}$		137	162	66	80	139	144				
28.333	317	0.33	$M_2$	53	172	108		183		147				
			c	4.7	1.6	2.4		1.7		1.7				
			$n_{2 \text{ Eck}}$	139	120	143		71		145				
			$n_{2 \text{ th}}$	139	120	143		71		127				
32.267	363	0.22	$M_2$	60	196	123								
			c	4.8	1.6	2.4								
			$n_{2 \text{ Eck}}$	122	106	126								
			$n_{2 \text{ th}}$	122	106	126								
36.667	322	0.22	$M_2$	69	224	141								
			c	3.7	1.2	1.9								
			$n_{2 \text{ Eck}}$	108	93	111								
			$n_{2 \text{ th}}$	108	93	110								
39.160	368	0.16	$M_2$	74	239	150								
			c	4.0	1.3	2.0								
			$n_{2 \text{ Eck}}$	101	87	103								
			$n_{2 \text{ th}}$	101	87	103								
44.500	325	0.16	$M_2$	84	272	171								
			c	3.4	1.2	1.7								
			$n_{2 \text{ Eck}}$	89	77	91								
			$n_{2 \text{ th}}$	89	77	91								
49.500	278	0.11	$M_2$	94										
			c	2.6										
			$n_{2 \text{ Eck}}$	80										
			$n_{2 \text{ th}}$	80										
56.250	316	0.11	$M_2$	107										
			c	2.6										
			$n_{2 \text{ Eck}}$	70										
			$n_{2 \text{ th}}$	70										

$M \dots$  [Nm]  
 $n \dots$  [r/min]  
 $J \dots$  [kgcm<sup>2</sup>]

$P \dots$  [kW]  
 $I \dots$  [A]  
 $i$  [-]  
 $c$  [-]

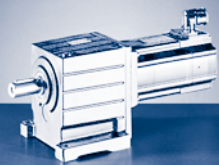

# GST [Nm]

## GST□□-□A (MCA)

$M_{2GN} \leq 375 \text{ Nm}$

GST06-3A				10IC40	13IC34	13IC41
				...500	...F10	...500
i	$M_{2GN}$	$J_G$	$M_1$			
			$n_1$	3950	3410	4050
			$I_{M400}$	2.4	6.0	4.4
			$P_N$	0.80	2.20	1.70
			$J_M$	2.44	8.34	8.34
39.200	321	0.36	$M_2$	73	236	149
			c	3.5	1.2	1.8
			$n_{2 \text{ Eck}}$	101	87	103
			$n_{2 \text{ th}}$	101	87	103
44.000	335	0.20	$M_2$	82	264	167
			c	3.6	1.2	1.8
			$n_{2 \text{ Eck}}$	90	78	92
			$n_{2 \text{ th}}$	90	78	92
51.022	325	0.32	$M_2$	95	307	194
			c	3.0	1.0	1.5
			$n_{2 \text{ Eck}}$	77	67	79
			$n_{2 \text{ th}}$	77	67	79
53.900	349	0.18	$M_2$	101	324	205
			c	3.1	1.0	1.5
			$n_{2 \text{ Eck}}$	73	63	75
			$n_{2 \text{ th}}$	73	63	75
67.760	365	0.11	$M_2$	127		
			c	2.6		
			$n_{2 \text{ Eck}}$	58		
			$n_{2 \text{ th}}$	58		
70.156	359	0.16	$M_2$	132		268
			c	2.4		1.2
			$n_{2 \text{ Eck}}$	56		58
			$n_{2 \text{ th}}$	56		58
80.952	332	0.20	$M_2$	153		
			c	2.0		
			$n_{2 \text{ Eck}}$	49		
			$n_{2 \text{ th}}$	49		
87.267	370	0.15	$M_2$	165		334
			c	2.0		1.0
			$n_{2 \text{ Eck}}$	45		46
			$n_{2 \text{ th}}$	45		46
99.167	336	0.15	$M_2$	188		
			c	1.6		
			$n_{2 \text{ Eck}}$	40		
			$n_{2 \text{ th}}$	40		
109.707	375	0.10	$M_2$	208		
			c	1.6		
			$n_{2 \text{ Eck}}$	36		
			$n_{2 \text{ th}}$	36		
124.667	339	0.10	$M_2$	238		
			c	1.3		
			$n_{2 \text{ Eck}}$	32		
			$n_{2 \text{ th}}$	32		
141.289	375	0.06	$M_2$	269		
			c	1.3		
			$n_{2 \text{ Eck}}$	28		
			$n_{2 \text{ th}}$	28		
160.556	342	0.06	$M_2$	307		
			c	1.0		
			$n_{2 \text{ Eck}}$	25		
			$n_{2 \text{ th}}$	25		

$M \dots$  [Nm]  
 $n \dots$  [r/min]  
 $J \dots$  [kgcm<sup>2</sup>]

$P \dots$  [kW]  
 $I \dots$  [A]  
 $i$  [-]  
 $c$  [-]

**GST [Nm]**  
GST□□-□A (MCA)

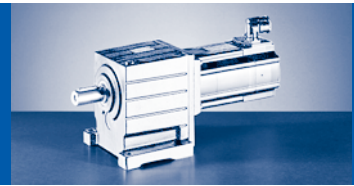

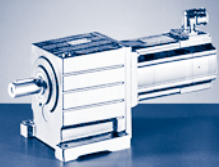

# GST [Nm]

## GST□□-□A (MCA)

$M_{2GN} \leq 196 \text{ Nm}$

GST07-1A				10IC40	13IC34	13IC41	14LC16	14LC20	14LC35	14LC41	17NC17	17NC23	
				...500	...F10	...500	...F10	...500	...F10	...500	...F10	...500	
i	$M_{2GN}$	$J_G$	$M_1$	2.00	6.30	4.00	12.00	6.70	10.80	5.40	21.50	10.80	
			$n_1$	3950	3410	4050	1635	2000	3455	4100	1680	2300	
			$I_{M400}$	2.4	6.0	4.4	4.8	3.3	9.1	5.8	8.5	5.5	
			$P_N$	0.80	2.20	1.70	2.10	1.40	3.90	2.30	3.80	2.60	
			$J_M$	2.44	8.34	8.34	19.32	19.24	19.24	19.24	36.04	36.04	
1.625	106	6.12	$M_2$								34	17	
			c								3.0	5.3	
			$n_{2\text{ Eck}}$									1034	1415
			$n_{2\text{ th}}$									1034	1415
2.000	124	4.78	$M_2$				23		21		42	20	
			c				5.1		4.4		2.8	5.1	
			$n_{2\text{ Eck}}$				818		1728		840	1150	
			$n_{2\text{ th}}$				818		1386		840	1150	
2.240	135	4.02	$M_2$				25		23		47	23	
			c				4.9		4.3		2.7	4.9	
			$n_{2\text{ Eck}}$				730		1542		750	1027	
			$n_{2\text{ th}}$				730		1280		750	1027	
2.857	118	2.69	$M_2$		17								
			c		5.1								
			$n_{2\text{ Eck}}$		1194								
			$n_{2\text{ th}}$		1194								
2.857	159	2.69	$M_2$				33		29		60	29	
			c				4.6		4.0		2.5	4.5	
			$n_{2\text{ Eck}}$				572		1209		588	805	
			$n_{2\text{ th}}$				572		1154		588	805	
3.500	172	2.15	$M_2$				40		36		73	36	
			c				4.0		3.5		2.2	4.0	
			$n_{2\text{ Eck}}$				467		987		480	657	
			$n_{2\text{ th}}$				467		987		480	657	
4.556	150	1.37	$M_2$		27	17							
			c		4.0	6.0							
			$n_{2\text{ Eck}}$		749	889							
			$n_{2\text{ th}}$		749	889							
4.556	186	1.37	$M_2$				53	29	48	23	96	47	
			c				3.4	5.6	2.9	5.5	1.9	3.3	
			$n_{2\text{ Eck}}$				359	439	758	900	369	505	
			$n_{2\text{ th}}$				359	439	758	788	369	505	
5.583	156	1.05	$M_2$		34	21							
			c		3.4	5.1							
			$n_{2\text{ Eck}}$		611	725							
			$n_{2\text{ th}}$		611	725							
5.583	196	1.05	$M_2$				65	35	58	29	118	58	
			c				2.9	4.8	2.5	4.7	1.6	2.9	
			$n_{2\text{ Eck}}$				293	358	619	734	301	412	
			$n_{2\text{ th}}$				293	358	619	643	301	412	
7.333	107	0.66	$M_2$	14									
			c	5.3									
			$n_{2\text{ Eck}}$	539									
			$n_{2\text{ th}}$	539									
7.333	161	0.66	$M_2$		45	28							
			c		2.7	4.0							
			$n_{2\text{ Eck}}$		465	552							
			$n_{2\text{ th}}$		465	552							
7.333	196	0.66	$M_2$				86	47	77	38			
			c				2.2	3.7	1.9	3.6			
			$n_{2\text{ Eck}}$				223	273	471	559			
			$n_{2\text{ th}}$				223	273	471	490			

$M \dots$  [Nm]  
 $n \dots$  [r/min]  
 $J \dots$  [kgcm<sup>2</sup>]

$P \dots$  [kW]  
 $I \dots$  [A]  
 $i$  [-]  
 $c$  [-]

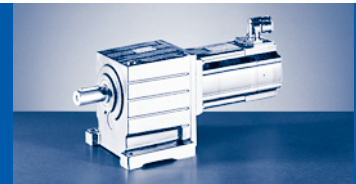

$M_{2GN} \leq 196 \text{ Nm}$

17NC35	17NC41	19SC17	19SC23	19SC35	19SC42	21XC17	21XC25	21XC42	GST07-1A			
...F10	...S00	...F10	...S00	...F10	...S00	...F10	...S00	...S00				
19.00	9.50	36.30	16.30	36.00	12.00	61.40	24.60	17.00	$M_1$	$J_G$	$M_{2GN}$	$i$
3480	4110	1700	2340	3510	4150	1710	2490	4160	$n_1$			
15.8	10.2	13.9	8.2	28.7	14.0	22.5	13.5	19.8	$l_{M400}$			
6.90	4.10	6.40	4.00	13.20	5.20	11.00	6.40	7.40	$P_N$			
36.04	36.04	72.12	72.12	72.04	72.12	180.04	180.04	180.04	$J_M$			
30	15	58	25	57	19	98	39	27	$M_2$			
2.6	5.0	1.8	3.5	1.4	3.9	1.0	2.3	2.8	c	6.12	106	1.625
2142	2529	1046	1440	2160	2554	1052	1532	2560	$n_{2 \text{ Eck}}$			
1347	1547	1046	1437	1027	1473	887	1239	1239	$n_{2 \text{ th}}$			
37	18	71	31	71	23		48	33	$M_2$			
2.5	4.7	1.7	3.3	1.3	3.7		2.2	2.6	c	4.78	124	2.000
1740	2055	850	1170	1755	2075		1245	2080	$n_{2 \text{ Eck}}$			
1225	1406	850	1170	915	1224		1007	1007	$n_{2 \text{ th}}$			
41	20	80	35	79	26		54	37	$M_2$			
2.4	4.6	1.6	3.2	1.3	3.6		2.1	2.6	c	4.02	135	2.240
1554	1835	759	1045	1567	1853		1112	1857	$n_{2 \text{ Eck}}$			
1136	1298	759	1045	854	1093		899	899	$n_{2 \text{ th}}$			
									$M_2$			
									c	2.69	118	2.857
									$n_{2 \text{ Eck}}$			
									$n_{2 \text{ th}}$			
53	26	102	45	101	33				$M_2$			
2.2	4.2	1.5	3.0	1.2	3.4				c	2.69	159	2.857
1218	1439	595	819	1229	1453				$n_{2 \text{ Eck}}$			
1027	1089	595	819	753	857				$n_{2 \text{ th}}$			
65	32	125	55	124	41				$M_2$			
2.0	3.8	1.3	2.6	1.0	3.0				c	2.15	172	3.500
994	1174	486	669	1003	1186				$n_{2 \text{ Eck}}$			
889	889	486	669	663	700				$n_{2 \text{ th}}$			
									$M_2$			
									c	1.37	150	4.556
									$n_{2 \text{ Eck}}$			
									$n_{2 \text{ th}}$			
85	42								$M_2$			
1.7	3.1								c	1.37	186	4.556
764	902								$n_{2 \text{ Eck}}$			
683	683								$n_{2 \text{ th}}$			
									$M_2$			
									c	1.05	156	5.583
									$n_{2 \text{ Eck}}$			
									$n_{2 \text{ th}}$			
104	51								$M_2$			
1.4	2.7								c	1.05	196	5.583
623	736								$n_{2 \text{ Eck}}$			
557	557								$n_{2 \text{ th}}$			
									$M_2$			
									c	0.66	107	7.333
									$n_{2 \text{ Eck}}$			
									$n_{2 \text{ th}}$			
									$M_2$			
									c	0.66	161	7.333
									$n_{2 \text{ Eck}}$			
									$n_{2 \text{ th}}$			
									$M_2$			
									c	0.66	196	7.333
									$n_{2 \text{ Eck}}$			
									$n_{2 \text{ th}}$			

M ... [Nm]  
n ... [r/min]  
J ... [kgcm<sup>2</sup>]

P ... [kW]  
I ... [A]  
i [-]  
c [-]

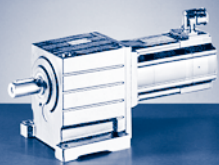

# GST [Nm]

## GST□□-□A (MCA)

$M_{2GN} \leq 196 \text{ Nm}$

GST07-1A				10IC40	13IC34	13IC41	14LC16	14LC20	14LC35	14LC41	17NC17	17NC23
				...S00	...F10	...S00	...F10	...S00	...F10	...S00	...F10	...S00
i	$M_{2GN}$	$J_G$	$M_1$	2.00	6.30	4.00	12.00	6.70	10.80	5.40	21.50	10.80
			$n_1$	3950	3410	4050	1635	2000	3455	4100	1680	2300
			$I_{M400}$	2.4	6.0	4.4	4.8	3.3	9.1	5.8	8.5	5.5
			$P_N$	0.80	2.20	1.70	2.10	1.40	3.90	2.30	3.80	2.60
			$J_M$	2.44	8.34	8.34	19.32	19.24	19.24	19.24	36.04	36.04
8.900	113	0.49	$M_2$	17								
			c	4.7								
			$n_{2 \text{ Eck}}$	444								
			$n_{2 \text{ th}}$	444								
8.900	164	0.49	$M_2$		55	34						
			c		2.3	3.4						
			$n_{2 \text{ Eck}}$		383	455						
			$n_{2 \text{ th}}$		383	455						
8.900	183	0.49	$M_2$				104	58	94	46		
			c				1.7	2.8	1.5	2.8		
			$n_{2 \text{ Eck}}$				184	225	388	461		
			$n_{2 \text{ th}}$				184	225	388	403		
11.250	114	0.32	$M_2$	22								
			c	3.7								
			$n_{2 \text{ Eck}}$	351								
			$n_{2 \text{ th}}$	351								
11.250	136	0.32	$M_2$		69	44						
			c		1.5	2.2						
			$n_{2 \text{ Eck}}$		303	360						
			$n_{2 \text{ th}}$		303	360						

$M \dots$  [Nm]  
 $n \dots$  [r/min]  
 $J \dots$  [kgcm<sup>2</sup>]

$P \dots$  [kW]  
 $I \dots$  [A]  
 $i \dots$  [-]  
 $c \dots$  [-]

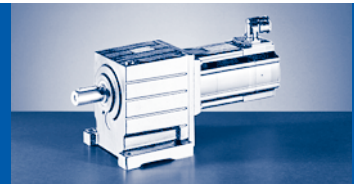

$M_{2GN} \leq 196 \text{ Nm}$

17NC35	17NC41	19SC17	19SC23	19SC35	19SC42	21XC17	21XC25	21XC42	GST07-1A			
...F10	...S00	...F10	...S00	...F10	...S00	...F10	...S00	...S00	$M_1$	$J_G$	$M_{2GN}$	$i$
19.00	9.50	36.30	16.30	36.00	12.00	61.40	24.60	17.00	$n_1$			
3480	4110	1700	2340	3510	4150	1710	2490	4160	$I_{M400}$			
15.8	10.2	13.9	8.2	28.7	14.0	22.5	13.5	19.8	$P_N$			
6.90	4.10	6.40	4.00	13.20	5.20	11.00	6.40	7.40	$J_M$			
36.04	36.04	72.12	72.12	72.04	72.12	180.04	180.04	180.04	$M_2$ c			
									$n_{2\text{ Eck}}$ $n_{2\text{ th}}$	0.49	113	8.900
									$M_2$ c			
									$n_{2\text{ Eck}}$ $n_{2\text{ th}}$	0.49	164	8.900
									$M_2$ c			
									$n_{2\text{ Eck}}$ $n_{2\text{ th}}$	0.49	183	8.900
									$M_2$ c			
									$n_{2\text{ Eck}}$ $n_{2\text{ th}}$	0.32	114	11.250
									$M_2$ c			
									$n_{2\text{ Eck}}$ $n_{2\text{ th}}$	0.32	136	11.250

M ... [Nm]  
n ... [r/min]  
J ... [kgcm<sup>2</sup>]

P ... [kW]  
I ... [A]  
i [-]  
c [-]

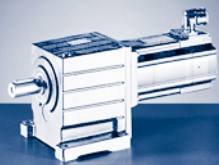

# GST [Nm]

## GST□□-□A (MCA)

$M_{2GN} \leq 707 \text{ Nm}$

GST07-2A				10IC40	13IC34	13IC41	14LC16	14LC20	14LC35	14LC41	17NC17	17NC23
				...500	...F10	...500	...F10	...500	...F10	...500	...F10	...500
i	$M_{2GN}$	$J_G$	$M_1$	2.00	6.30	4.00	12.00	6.70	10.80	5.40	21.50	10.80
			$n_1$	3950	3410	4050	1635	2000	3455	4100	1680	2300
			$I_{M400}$	2.4	6.0	4.4	4.8	3.3	9.1	5.8	8.5	5.5
			$P_N$	0.80	2.20	1.70	2.10	1.40	3.90	2.30	3.80	2.60
			$J_M$	2.44	8.34	8.34	19.32	19.24	19.24	19.24	36.04	36.04
3.048	317	8.20	$M_2$ c $n_{2 \text{ Eck}}$ $n_{2 \text{ th}}$								61 4.8 551 551	
3.048	351	8.20	$M_2$ c $n_{2 \text{ Eck}}$ $n_{2 \text{ th}}$									
3.350	349	7.92	$M_2$ c $n_{2 \text{ Eck}}$ $n_{2 \text{ th}}$								67 4.8 502 502	
3.350	367	7.92	$M_2$ c $n_{2 \text{ Eck}}$ $n_{2 \text{ th}}$									
4.225	398	7.65	$M_2$ c $n_{2 \text{ Eck}}$ $n_{2 \text{ th}}$								85 4.4 398 398	
4.643	414	7.39	$M_2$ c $n_{2 \text{ Eck}}$ $n_{2 \text{ th}}$								94 4.1 362 362	
5.200	405	5.64	$M_2$ c $n_{2 \text{ Eck}}$ $n_{2 \text{ th}}$						52 5.6 664 560			
5.200	427	5.64	$M_2$ c $n_{2 \text{ Eck}}$ $n_{2 \text{ th}}$								105 3.8 323 323	
5.714	445	5.46	$M_2$ c $n_{2 \text{ Eck}}$ $n_{2 \text{ th}}$						57 5.6 605 510			
5.714	448	5.46	$M_2$ c $n_{2 \text{ Eck}}$ $n_{2 \text{ th}}$								116 3.6 294 294	
6.400	463	4.49	$M_2$ c $n_{2 \text{ Eck}}$ $n_{2 \text{ th}}$						64 5.2 540 466		130 3.3 263 263	64 6.0 359 359
7.150	489	6.27	$M_2$ c $n_{2 \text{ Eck}}$ $n_{2 \text{ th}}$								146 3.2 235 235	71 5.7 322 322
8.125	539	6.04	$M_2$ c $n_{2 \text{ Eck}}$ $n_{2 \text{ th}}$								166 3.1 207 207	81 5.5 283 283

$M \dots$  [Nm]  
 $n \dots$  [r/min]  
 $J \dots$  [kgcm<sup>2</sup>]

$P \dots$  [kW]  
 $I \dots$  [A]  
 $i$  [-]  
 $c$  [-]

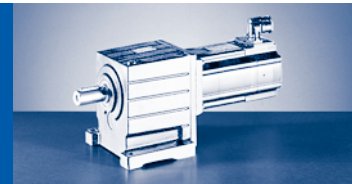

$M_{2GN} \leq 707 \text{ Nm}$

17NC35	17NC41	19SC17	19SC23	19SC35	19SC42	21XC17	21XC25	21XC35	21XC42	GST07-2A			
...F10	...S00	...F10	...S00	...F10	...S00	...F10	...S00	...F10	...S00	$M_1$	$J_G$	$M_{2GN}$	i
19.00	9.50	36.30	16.30	36.00	12.00	61.40	24.60	55.00	17.00	$n_1$			
3480	4110	1700	2340	3510	4150	1710	2490	3520	4160	$l_{M400}$			
15.8	10.2	13.9	8.2	28.7	14.0	22.5	13.5	42.5	19.8	$P_N$			
6.90	4.10	6.40	4.00	13.20	5.20	11.00	6.40	20.30	7.40	$J_M$			
36.04	36.04	72.12	72.12	72.04	72.12	180.04	180.04	180.04	180.04	$M_2$			
54										c			
4.3										$n_{2\text{ Eck}}$	8.20	317	3.048
1142										$n_{2\text{ th}}$			
693										$M_2$			
		105		105		180	70	162	48	c			
		3.1		2.5		1.9	4.1	1.6	5.0	$n_{2\text{ Eck}}$	8.20	351	3.048
		558		1152		561	817	1155	1365	$n_{2\text{ th}}$			
		558		610		554	661	511	661	$M_2$			
60										c			
4.3										$n_{2\text{ Eck}}$	7.92	349	3.350
1039										$n_{2\text{ th}}$			
631										$M_2$			
		116	50	115		198	78	178	53	c			
		3.0	6.0	2.4		1.8	3.9	1.5	4.7	$n_{2\text{ Eck}}$	7.92	367	3.350
		508	699	1048		511	743	1051	1242	$n_{2\text{ th}}$			
		508	678	548		488	601	451	601	$M_2$			
76		146	64	146	47	250	98	225	67	c			
3.9		2.6	5.1	2.0	5.8	1.5	3.3	1.3	4.1	$n_{2\text{ Eck}}$	7.65	398	4.225
824		402	554	831	982	405	589	833	985	$n_{2\text{ th}}$			
564		402	554	487	580	405	477	386	477	$M_2$			
83		161	71	161	52	275	108	247	74	c			
3.7		2.4	4.9	1.9	5.5	1.4	3.2	1.3	3.9	$n_{2\text{ Eck}}$	7.39	414	4.643
750		366	504	756	894	368	536	758	896	$n_{2\text{ th}}$			
507		366	504	434	527	366	434	341	434	$M_2$			
										c			
										$n_{2\text{ Eck}}$	5.64	405	5.200
										$n_{2\text{ th}}$			
94		181	79	180	58	309	122	277	84	$M_2$			
3.4		2.2	4.5	1.8	5.0	1.3	2.9	1.2	3.6	c			
669		327	450	675	798	329	479	677	800	$n_{2\text{ Eck}}$	5.64	427	5.200
504		327	450	417	471	329	387	330	387	$n_{2\text{ th}}$			
										$M_2$			
										c			
										$n_{2\text{ Eck}}$	5.46	445	5.714
										$n_{2\text{ th}}$			
103		199	87	198	64	339	134	305	92	$M_2$			
3.2		2.1	4.3	1.7	4.8	1.3	2.8	1.1	3.4	c			
609		298	410	614	726	299	436	616	728	$n_{2\text{ Eck}}$	5.46	448	5.714
454		298	410	369	429	299	352	293	352	$n_{2\text{ th}}$			
116	56	223	98	222	72	381	150	341	103	$M_2$			
3.0	5.6	2.0	4.0	1.6	4.4	1.2	2.6	1.0	3.1	c			
544	642	266	366	548	648	267	389	550	650	$n_{2\text{ Eck}}$	4.49	463	6.400
415	472	266	366	332	383	267	315	269	315	$n_{2\text{ th}}$			
129	63	250	110	249	81	426	168		116	$M_2$			
2.8	5.3	1.9	3.7	1.5	4.2	1.1	2.4		3.0	c			
487	575	238	327	491	580	239	348		582	$n_{2\text{ Eck}}$	6.27	489	7.150
311	356	238	327	241	339	207	282		282	$n_{2\text{ th}}$			
147	72	284	125	283	92	484	191		131	$M_2$			
2.7	5.1	1.8	3.6	1.4	4.1	1.1	2.4		2.9	c			
428	506	209	288	432	511	211	307		512	$n_{2\text{ Eck}}$	6.04	539	8.125
271	311	209	288	209	297	180	248		248	$n_{2\text{ th}}$			

M ... [Nm]  
n ... [r/min]  
J ... [kgcm<sup>2</sup>]

P ... [kW]  
I ... [A]  
i [-]  
c [-]

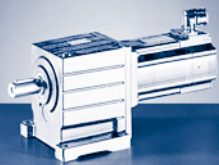

# GST [Nm]

## GST□□-□A (MCA)

$M_{2GN} \leq 707 \text{ Nm}$

GST07-2A				10IC40	13IC34	13IC41	14LC16	14LC20	14LC35	14LC41	17NC17	17NC23
				...500	...F10	...500	...F10	...500	...F10	...500	...F10	...500
i	$M_{2GN}$	$J_G$	$M_1$	2.00	6.30	4.00	12.00	6.70	10.80	5.40	21.50	10.80
			$n_1$	3950	3410	4050	1635	2000	3455	4100	1680	2300
			$I_{M400}$	2.4	6.0	4.4	4.8	3.3	9.1	5.8	8.5	5.5
			$P_N$	0.80	2.20	1.70	2.10	1.40	3.90	2.30	3.80	2.60
			$J_M$	2.44	8.34	8.34	19.32	19.24	19.24	19.24	36.04	36.04
8.800	527	4.73	$M_2$				98		89		180	88
			c				5.0		4.3		2.8	5.0
			$n_{2 \text{ Eck}}$				186		393		191	261
			$n_{2 \text{ th}}$				186		314		191	261
9.856	549	3.90	$M_2$				110		100		202	99
			c				4.7		4.0		2.6	4.6
			$n_{2 \text{ Eck}}$				166		351		171	233
			$n_{2 \text{ th}}$				166		287		170	233
11.200	598	3.78	$M_2$				126		114		230	113
			c				4.5		3.9		2.5	4.4
			$n_{2 \text{ Eck}}$				146		309		150	205
			$n_{2 \text{ th}}$				146		251		150	205
12.571	513	2.86	$M_2$		74							
			c		5.1							
			$n_{2 \text{ Eck}}$		271							
			$n_{2 \text{ th}}$		271							
12.571	601	2.86	$M_2$				142		128		259	128
			c				4.0		3.5		2.2	4.0
			$n_{2 \text{ Eck}}$				130		275		134	183
			$n_{2 \text{ th}}$				130		255		134	183
14.286	583	2.79	$M_2$		84							
			c		5.1							
			$n_{2 \text{ Eck}}$		239							
			$n_{2 \text{ th}}$		239							
14.286	642	2.79	$M_2$				162		146		295	146
			c				3.8		3.3		2.1	3.7
			$n_{2 \text{ Eck}}$				115		242		118	161
			$n_{2 \text{ th}}$				114		222		118	161
15.400	644	2.26	$M_2$				175		157		318	156
			c				3.6		3.4		2.0	3.9
			$n_{2 \text{ Eck}}$				106		224		109	149
			$n_{2 \text{ th}}$				106		224		109	149
17.500	680	2.21	$M_2$				199	108	179		362	178
			c				3.3	6.0	3.2		1.9	3.7
			$n_{2 \text{ Eck}}$				93	114	197		96	131
			$n_{2 \text{ th}}$				93	114	197		96	131
20.044	650	1.38	$M_2$		118							
			c		4.6							
			$n_{2 \text{ Eck}}$		170							
			$n_{2 \text{ th}}$		170							
20.044	694	1.38	$M_2$				229	124	206	100	415	205
			c				3.0	5.3	2.8	5.4	1.7	3.3
			$n_{2 \text{ Eck}}$				82	100	172	205	84	115
			$n_{2 \text{ th}}$				82	100	172	179	84	115
22.778	682	1.35	$M_2$		135		261	143	235	115	473	234
			c		4.2		2.6	4.6	2.5	4.6	1.4	2.8
			$n_{2 \text{ Eck}}$		150		72	88	152	180	74	101
			$n_{2 \text{ th}}$		150		72	88	152	158	74	101
24.567	677	1.02	$M_2$		146	91						
			c		3.9	5.8						
			$n_{2 \text{ Eck}}$		139	165						
			$n_{2 \text{ th}}$		139	165						

$M \dots$  [Nm]  
 $n \dots$  [r/min]  
 $J \dots$  [kgcm<sup>2</sup>]

$P \dots$  [kW]  
 $I \dots$  [A]  
 $i$  [-]  
 $c$  [-]

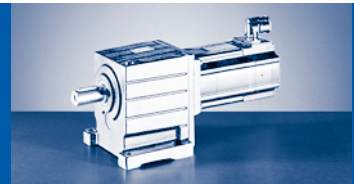

$M_{2GN} \leq 707 \text{ Nm}$

17NC35	17NC41	19SC17	19SC23	19SC35	19SC42	21XC17	21XC25	21XC35	21XC42	GST07-2A			
...F10	...S00	...F10	...S00	...F10	...S00	...F10	...S00	...F10	...S00	$M_1$	$J_G$	$M_{2GN}$	i
19.00	9.50	36.30	16.30	36.00	12.00	61.40	24.60	55.00	17.00	$n_1$			
3480	4110	1700	2340	3510	4150	1710	2490	3520	4160	$I_{M400}$			
15.8	10.2	13.9	8.2	28.7	14.0	22.5	13.5	42.5	19.8	$P_N$			
6.90	4.10	6.40	4.00	13.20	5.20	11.00	6.40	20.30	7.40	$J_M$			
36.04	36.04	72.12	72.12	72.04	72.12	180.04	180.04	180.04	180.04	$M_2$			
160	78	308	136	306	100		208		143	c	4.73	527	8.800
2.5	4.6	1.6	3.3	1.3	3.7		2.1		2.6	$n_{2 \text{ Eck}}$			
396	467	193	266	399	472		283		473	$n_{2 \text{ th}}$			
277	318	193	266	206	278		229		229				
179	88	345	153	344	112		233		160	$M_2$			
2.3	4.3	1.5	3.0	1.2	3.4		2.0		2.4	c	3.90	549	9.856
353	417	173	237	356	421		253		422	$n_{2 \text{ Eck}}$			
255	292	172	237	189	248		204		204	$n_{2 \text{ th}}$			
204	100	393	174	391	127		265		182	$M_2$			
2.2	4.1	1.5	2.9	1.2	3.3		1.9		2.3	c	3.78	598	11.200
311	367	152	209	313	371		222		371	$n_{2 \text{ Eck}}$			
222	254	152	209	163	219		180		180	$n_{2 \text{ th}}$			
										$M_2$			
										c	2.86	513	12.571
										$n_{2 \text{ Eck}}$			
										$n_{2 \text{ th}}$			
229	113	441	196	439	143					$M_2$			
2.0	3.7	1.3	2.6	1.0	2.9					c	2.86	601	12.571
277	327	135	186	279	330					$n_{2 \text{ Eck}}$			
226	247	135	186	161	195					$n_{2 \text{ th}}$			
										$M_2$			
										c	2.79	583	14.286
										$n_{2 \text{ Eck}}$			
										$n_{2 \text{ th}}$			
261	128	502	223		163					$M_2$			
1.8	3.5	1.2	2.5		2.8					c	2.79	642	14.286
244	288	119	164		291					$n_{2 \text{ Eck}}$			
192	218	119	164		171					$n_{2 \text{ th}}$			
281	138	541	240	538	176					$M_2$			
2.0	3.7	1.2	2.6	1.0	2.9					c	2.26	644	15.400
226	267	110	152	228	270					$n_{2 \text{ Eck}}$			
202	202	110	152	150	159					$n_{2 \text{ th}}$			
320	157	616	273		200					$M_2$			
1.8	3.4	1.1	2.4		2.7					c	2.21	680	17.500
199	235	97	134		237					$n_{2 \text{ Eck}}$			
171	178	97	134		140					$n_{2 \text{ th}}$			
										$M_2$			
										c	1.38	650	20.044
										$n_{2 \text{ Eck}}$			
										$n_{2 \text{ th}}$			
367	181									$M_2$			
1.6	3.1									c	1.38	694	20.044
174	205									$n_{2 \text{ Eck}}$			
155	155									$n_{2 \text{ th}}$			
418	206									$M_2$			
1.4	2.6									c	1.35	682	22.778
153	180									$n_{2 \text{ Eck}}$			
137	137									$n_{2 \text{ th}}$			
										$M_2$			
										c	1.02	677	24.567
										$n_{2 \text{ Eck}}$			
										$n_{2 \text{ th}}$			

$M \dots$  [Nm]  
 $n \dots$  [r/min]  
 $J \dots$  [kgcm<sup>2</sup>]

$P \dots$  [kW]  
 $I \dots$  [A]  
 $i$  [-]  
 $c$  [-]



# GST [Nm]

## GST□□-□A (MCA)

$M_{2GN} \leq 707 \text{ Nm}$

GST07-2A				10IC40	13IC34	13IC41	14LC16	14LC20	14LC35	14LC41	17NC17	17NC23
				...500	...F10	...500	...F10	...500	...F10	...500	...F10	...500
i	$M_{2GN}$	$J_G$	$M_1$	2.00	6.30	4.00	12.00	6.70	10.80	5.40	21.50	10.80
			$n_1$	3950	3410	4050	1635	2000	3455	4100	1680	2300
			$I_{M400}$	2.4	6.0	4.4	4.8	3.3	9.1	5.8	8.5	5.5
			$P_N$	0.80	2.20	1.70	2.10	1.40	3.90	2.30	3.80	2.60
			$J_M$	2.44	8.34	8.34	19.32	19.24	19.24	19.24	36.04	36.04
24.567	706	1.02	$M_2$				282	154	254	124	510	253
			c				2.5	4.4	2.4	4.5	1.4	2.7
			$n_{2 \text{ Eck}}$				67	81	141	167	68	94
			$n_{2 \text{ th}}$				67	81	141	146	68	94
27.917	691	1.01	$M_2$		166	104	321	176	289	142	581	289
			c		3.5	5.2	2.1	3.8	2.0	3.8	1.2	2.3
			$n_{2 \text{ Eck}}$		122	145	59	72	124	147	60	82
			$n_{2 \text{ th}}$		122	145	59	72	124	129	60	82
32.267	698	0.66	$M_2$		193	121						
			c		3.1	4.6						
			$n_{2 \text{ Eck}}$		106	126						
			$n_{2 \text{ th}}$		106	126						
32.267	706	0.66	$M_2$				372	205	335	165		
			c				1.9	3.4	1.8	3.4		
			$n_{2 \text{ Eck}}$				51	62	107	127		
			$n_{2 \text{ th}}$				51	62	107	111		
36.667	702	0.65	$M_2$		220	138	424	234	382	188		
			c		2.7	4.0	1.6	3.0	1.6	3.0		
			$n_{2 \text{ Eck}}$		93	111	45	55	94	112		
			$n_{2 \text{ th}}$		93	110	45	55	94	98		
39.160	491	0.49	$M_2$	73								
			c	5.3								
			$n_{2 \text{ Eck}}$	101								
			$n_{2 \text{ th}}$	101								
39.160	706	0.49	$M_2$		236	148	453	250	408	201		
			c		2.6	3.8	1.6	2.8	1.5	2.8		
			$n_{2 \text{ Eck}}$		87	103	42	51	88	105		
			$n_{2 \text{ th}}$		87	103	42	51	88	92		
44.500	558	0.48	$M_2$	82								
			c	5.9								
			$n_{2 \text{ Eck}}$	89								
			$n_{2 \text{ th}}$	89								
44.500	707	0.48	$M_2$		268	168	516	285	464	229		
			c		2.5	3.7	1.4	2.4	1.5	2.7		
			$n_{2 \text{ Eck}}$		77	91	37	45	78	92		
			$n_{2 \text{ th}}$		77	91	37	45	78	81		
49.500	493	0.33	$M_2$	92								
			c	4.7								
			$n_{2 \text{ Eck}}$	80								
			$n_{2 \text{ th}}$	80								
49.500	600	0.33	$M_2$		300	188						
			c		1.9	2.8						
			$n_{2 \text{ Eck}}$		69	82						
			$n_{2 \text{ th}}$		69	82						
56.250	560	0.33	$M_2$	105								
			c	4.7								
			$n_{2 \text{ Eck}}$	70								
			$n_{2 \text{ th}}$	70								
56.250	688	0.33	$M_2$		341	214						
			c		1.9	2.9						
			$n_{2 \text{ Eck}}$		61	72						
			$n_{2 \text{ th}}$		61	72						

$M \dots$  [Nm]  
 $n \dots$  [r/min]  
 $J \dots$  [kgcm<sup>2</sup>]

$P \dots$  [kW]  
 $I \dots$  [A]  
 $i$  [-]  
 $c$  [-]

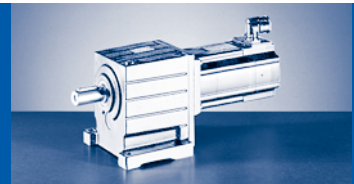

$M_{2GN} \leq 707 \text{ Nm}$

17NC35	17NC41	19SC17	19SC23	19SC35	19SC42	21XC17	21XC25	21XC35	21XC42	GST07-2A			
...F10	...S00	...F10	...S00	...F10	...S00	...F10	...S00	...F10	...S00	$M_1$	$J_G$	$M_{2GN}$	i
19.00	9.50	36.30	16.30	36.00	12.00	61.40	24.60	55.00	17.00	$n_1$			
3480	4110	1700	2340	3510	4150	1710	2490	3520	4160	$I_{M400}$			
15.8	10.2	13.9	8.2	28.7	14.0	22.5	13.5	42.5	19.8	$P_N$			
6.90	4.10	6.40	4.00	13.20	5.20	11.00	6.40	20.30	7.40	$J_M$			
36.04	36.04	72.12	72.12	72.04	72.12	180.04	180.04	180.04	180.04	$M_2$			
451	223									c			
1.3	2.5									$n_{2Eck}$	1.02	706	24.567
142	167									$n_{2th}$			
127	127									$M_2$			
514	254									c			
1.2	2.2									$n_{2Eck}$	1.01	691	27.917
125	147									$n_{2th}$			
111	111									$M_2$			
										c			
										$n_{2Eck}$	0.66	698	32.267
										$n_{2th}$			
										$M_2$			
										c			
										$n_{2Eck}$	0.66	706	32.267
										$n_{2th}$			
										$M_2$			
										c			
										$n_{2Eck}$	0.65	702	36.667
										$n_{2th}$			
										$M_2$			
										c			
										$n_{2Eck}$	0.49	491	39.160
										$n_{2th}$			
										$M_2$			
										c			
										$n_{2Eck}$	0.49	706	39.160
										$n_{2th}$			
										$M_2$			
										c			
										$n_{2Eck}$	0.48	558	44.500
										$n_{2th}$			
										$M_2$			
										c			
										$n_{2Eck}$	0.48	707	44.500
										$n_{2th}$			
										$M_2$			
										c			
										$n_{2Eck}$	0.33	493	49.500
										$n_{2th}$			
										$M_2$			
										c			
										$n_{2Eck}$	0.33	600	49.500
										$n_{2th}$			
										$M_2$			
										c			
										$n_{2Eck}$	0.33	560	56.250
										$n_{2th}$			
										$M_2$			
										c			
										$n_{2Eck}$	0.33	688	56.250
										$n_{2th}$			

M ... [Nm]  
n ... [r/min]  
J ... [kgcm<sup>2</sup>]

P ... [kW]  
I ... [A]  
i [-]  
c [-]

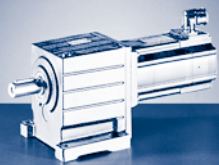

# GST [Nm]

## GST□□-□A (MCA)

$M_{2GN} \leq 710 \text{ Nm}$

GST07-3A				10IC40	13IC34	13IC41	14LC16	14LC20	14LC35	14LC41
i	$M_{2GN}$	$J_G$	$M_1$	...S00	...F10	...S00	...F10	...S00	...F10	...S00
			$n_1$	2.00	6.30	4.00	12.00	6.70	10.80	5.40
			$I_{M400}$	3950	3410	4050	1635	2000	3455	4100
			$P_N$	2.4	6.0	4.4	4.8	3.3	9.1	5.8
			$J_M$	0.80	2.20	1.70	2.10	1.40	3.90	2.30
			$M_2$	2.44	8.34	8.34	19.32	19.24	19.24	19.24
			c		232	146	447	246	403	199
			$n_{2 \text{ Eck}}$		2.5	3.8	1.5	2.8	1.5	2.8
			$n_{2 \text{ th}}$		87	103	42	51	88	105
			$M_2$		87	103	42	51	88	92
			c		261	163	502	277	452	223
			$n_{2 \text{ Eck}}$		2.6	3.8	1.4	2.5	1.5	2.8
			$n_{2 \text{ th}}$		78	92	37	46	79	93
			$M_2$		78	92	37	45	79	82
			c		303	190	584	323	525	259
			$n_{2 \text{ Eck}}$		2.2	3.3	1.2	2.1	1.3	2.4
			$n_{2 \text{ th}}$		67	79	32	39	68	80
			$M_2$		67	79	32	39	68	70
			c		321	202	617	341	555	274
			$n_{2 \text{ Eck}}$		2.1	3.1	1.1	2.1	1.2	2.3
			$n_{2 \text{ th}}$		63	75	30	37	64	76
			$M_2$		63	75	30	37	64	67
			c		119	389	245			
			$n_{2 \text{ Eck}}$		5.2	1.7	2.6			
			$n_{2 \text{ th}}$		61	52	62			
			$M_2$		61	52	62			
			c		129	420	264	447		359
			$n_{2 \text{ Eck}}$		4.8	1.6	2.4	1.6		1.8
			$n_{2 \text{ th}}$		56	49	58	29		58
			$M_2$		56	49	58	29		51
			c		147	478	301	509		409
			$n_{2 \text{ Eck}}$		4.3	1.4	2.1	1.4		1.6
			$n_{2 \text{ th}}$		50	43	51	25		51
			$M_2$		50	43	51	25		45
			c		159	516	325	549		442
			$n_{2 \text{ Eck}}$		3.9	1.3	1.9	1.3		1.4
			$n_{2 \text{ th}}$		46	40	47	23		48
			$M_2$		46	40	47	23		42
			c		182	587	371	625		503
			$n_{2 \text{ Eck}}$		3.5	1.2	1.7	1.1		1.3
			$n_{2 \text{ th}}$		40	35	42	21		42
			$M_2$		40	35	41	20		37
			c		209	674	426			
			$n_{2 \text{ Eck}}$		3.0	1.0	1.5			
			$n_{2 \text{ th}}$		35	31	36			
			$M_2$		35	30	36			
			c		239		485			
			$n_{2 \text{ Eck}}$		2.7		1.3			
			$n_{2 \text{ th}}$		31		32			
			$M_2$		31		32			
			c		262		531			
			$n_{2 \text{ Eck}}$		2.4		1.2			
			$n_{2 \text{ th}}$		28		29			
			$M_2$		28		29			
			c		299		604			
			$n_{2 \text{ Eck}}$		2.1		1.1			
			$n_{2 \text{ th}}$		25		26			
			$M_2$		25		26			

M ... [Nm]  
 n ... [r/min]  
 J ... [kgcm<sup>2</sup>]

P ... [kW]  
 I ... [A]  
 i [-]  
 c [-]

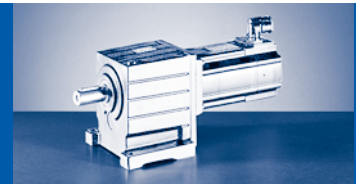

$M_{2GN} \leq 710 \text{ Nm}$

GST07-3A				10IC40	13IC34	13IC41	14LC16	14LC20	14LC35	14LC41
				...S00	...F10	...S00	...F10	...S00	...F10	...S00
i	$M_{2GN}$	$J_G$	$M_1$	2.00	6.30	4.00	12.00	6.70	10.80	5.40
			$n_1$	3950	3410	4050	1635	2000	3455	4100
			$I_{M400}$	2.4	6.0	4.4	4.8	3.3	9.1	5.8
			$P_N$	0.80	2.20	1.70	2.10	1.40	3.90	2.30
			$J_M$	2.44	8.34	8.34	19.32	19.24	19.24	19.24
180.156	706	0.11	$M_2$	341						
			c	1.9						
			$n_{2 \text{ Eck}}$	22						
			$n_{2 \text{ th}}$	22						
204.722	710	0.11	$M_2$	389						
			c	1.7						
			$n_{2 \text{ Eck}}$	19						
			$n_{2 \text{ th}}$	19						
236.622	706	0.10	$M_2$	450						
			c	1.4						
			$n_{2 \text{ Eck}}$	17						
			$n_{2 \text{ th}}$	17						
248.458	710	0.08	$M_2$	473						
			c	1.4						
			$n_{2 \text{ Eck}}$	16						
			$n_{2 \text{ th}}$	16						
268.889	710	0.10	$M_2$	513						
			c	1.3						
			$n_{2 \text{ Eck}}$	15						
			$n_{2 \text{ th}}$	15						
326.333	710	0.07	$M_2$	623						
			c	1.0						
			$n_{2 \text{ Eck}}$	12						
			$n_{2 \text{ th}}$	12						

M ... [Nm]  
n ... [r/min]  
J ... [kgcm<sup>2</sup>]

P ... [kW]  
I ... [A]  
i [-]  
c [-]

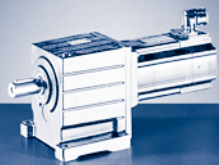

# GST [Nm]

## GST□□-□A (MCA)

$M_{2GN} \leq 465 \text{ Nm}$

GST09-1A				14LC16	14LC20	14LC35	14LC41	17NC17	17NC23	17NC35	17NC41
i	$M_{2GN}$	$J_G$	$M_1$	...F10	...S00	...F10	...S00	...F10	...S00	...F10	...S00
			$n_1$	12.00	6.70	10.80	5.40	21.50	10.80	19.00	9.50
			$I_{M400}$	4.8	3.3	9.1	5.8	8.5	5.5	15.8	10.2
			$P_N$	2.10	1.40	3.90	2.30	3.80	2.60	6.90	4.10
			$J_M$	19.32	19.24	19.24	19.24	36.04	36.04	36.04	36.04
1.560	277	22.20	$M_2$ c $n_{2 \text{ Eck}}$ $n_{2 \text{ th}}$								
2.048	239	15.60	$M_2$ c $n_{2 \text{ Eck}}$ $n_{2 \text{ th}}$					41 5.3 821 820		37 4.7 1700 1109	
2.048	338	15.60	$M_2$ c $n_{2 \text{ Eck}}$ $n_{2 \text{ th}}$								
2.333	245	12.20	$M_2$ c $n_{2 \text{ Eck}}$ $n_{2 \text{ th}}$					48 4.8 720 720		42 4.2 1491 1042	
2.333	370	12.20	$M_2$ c $n_{2 \text{ Eck}}$ $n_{2 \text{ th}}$								
2.810	221	9.58	$M_2$ c $n_{2 \text{ Eck}}$ $n_{2 \text{ th}}$			28 5.6 1230 1035					
2.810	259	9.58	$M_2$ c $n_{2 \text{ Eck}}$ $n_{2 \text{ th}}$					58 4.2 598 598		51 3.7 1239 952	
2.810	418	9.58	$M_2$ c $n_{2 \text{ Eck}}$ $n_{2 \text{ th}}$								
3.444	272	7.30	$M_2$ c $n_{2 \text{ Eck}}$ $n_{2 \text{ th}}$					71 3.6 488 488		63 3.2 1010 818	
3.444	443	7.30	$M_2$ c $n_{2 \text{ Eck}}$ $n_{2 \text{ th}}$								
4.667	247	4.60	$M_2$ c $n_{2 \text{ Eck}}$ $n_{2 \text{ th}}$	53 4.3 350 350		48 3.8 740 740					
4.667	289	4.60	$M_2$ c $n_{2 \text{ Eck}}$ $n_{2 \text{ th}}$					97 2.8 360 360	48 5.0 493 493	86 2.5 746 667	42 4.7 881 667
4.667	379	4.60	$M_2$ c $n_{2 \text{ Eck}}$ $n_{2 \text{ th}}$								

$M \dots$  [Nm]  
 $n \dots$  [r/min]  
 $J \dots$  [kgcm<sup>2</sup>]

$P \dots$  [kW]  
 $I \dots$  [A]  
 $i$  [-]  
 $c$  [-]

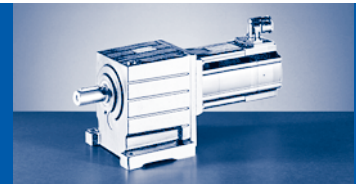

$M_{2GN} \leq 465 \text{ Nm}$

19SC17	19SC23	19SC35	19SC42	21XC17	21XC25	21XC35	21XC42	GST09-1A			
...F10	...500	...F10	...500	...F10	...500	...F10	...500	$M_1$	$J_G$	$M_{2GN}$	$i$
36.30	16.30	36.00	12.00	61.40	24.60	55.00	17.00	$n_1$			
1700	2340	3510	4150	1710	2490	3520	4160	$I_{M400}$			
13.9	8.2	28.7	14.0	22.5	13.5	42.5	19.8	$P_N$			
6.40	4.00	13.20	5.20	11.00	6.40	20.30	7.40	$J_M$			
72.12	72.12	72.04	72.12	180.04	180.04	180.04	180.04	$M_2$			
54		54		93		83		$c$	22.20	277	1.560
4.8		3.8		2.8		2.5		$n_{2 \text{ Eck}}$			
1090		2250		1096		2256		$n_{2 \text{ th}}$			
1090		1219		1096		1101		$M_2$			
								$c$	15.60	239	2.048
								$n_{2 \text{ Eck}}$			
								$n_{2 \text{ th}}$			
71		71		122	47	109		$M_2$	15.60	338	2.048
4.4		3.5		2.6	5.8	2.3		$c$			
830		1714		835	1216	1719		$n_{2 \text{ Eck}}$			
830		1041		835	983	943		$n_{2 \text{ th}}$			
								$M_2$	12.20	245	2.333
								$c$			
								$n_{2 \text{ Eck}}$			
								$n_{2 \text{ th}}$			
81		81		139	54	125		$M_2$	12.20	370	2.333
4.3		3.4		2.5	5.5	2.2		$c$			
729		1504		733	1067	1509		$n_{2 \text{ Eck}}$			
729		991		733	863	863		$n_{2 \text{ th}}$			
								$M_2$	9.58	221	2.810
								$c$			
								$n_{2 \text{ Eck}}$			
								$n_{2 \text{ th}}$			
								$M_2$	9.58	259	2.810
								$c$			
								$n_{2 \text{ Eck}}$			
								$n_{2 \text{ th}}$			
97		97		168	65	151		$M_2$	9.58	418	2.810
4.0		3.2		2.4	5.2	2.1		$c$			
605		1249		609	886	1253		$n_{2 \text{ Eck}}$			
605		872		609	717	717		$n_{2 \text{ th}}$			
								$M_2$	7.30	272	3.444
								$c$			
								$n_{2 \text{ Eck}}$			
								$n_{2 \text{ th}}$			
120		120		206	81	185	55	$M_2$	7.30	443	3.444
3.5		2.7		2.0	4.5	1.8	5.5	$c$			
494		1019		497	723	1022	1208	$n_{2 \text{ Eck}}$			
494		711		496	585	585	585	$n_{2 \text{ th}}$			
								$M_2$	4.60	247	4.667
								$c$			
								$n_{2 \text{ Eck}}$			
								$n_{2 \text{ th}}$			
								$M_2$	4.60	289	4.667
								$c$			
								$n_{2 \text{ Eck}}$			
								$n_{2 \text{ th}}$			
165	72	164	53					$M_2$	4.60	379	4.667
2.2	4.4	1.7	4.9					$c$			
364	501	752	889					$n_{2 \text{ Eck}}$			
364	501	525	525					$n_{2 \text{ th}}$			

M ... [Nm]  
n ... [r/min]  
J ... [kgcm<sup>2</sup>]

P ... [kW]  
I ... [A]  
i [-]  
c [-]

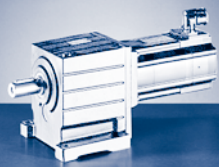

# GST [Nm]

## GST□□-□A (MCA)

$M_{2GN} \leq 465 \text{ Nm}$

GST09-1A				14LC16	14LC20	14LC35	14LC41	17NC17	17NC23	17NC35	17NC41
				...F10	...S00	...F10	...S00	...F10	...S00	...F10	...S00
i	$M_{2GN}$	$J_G$	$M_1$	12.00	6.70	10.80	5.40	21.50	10.80	19.00	9.50
			$n_1$	1635	2000	3455	4100	1680	2300	3480	4110
			$I_{M400}$	4.8	3.3	9.1	5.8	8.5	5.5	15.8	10.2
			$P_N$	2.10	1.40	3.90	2.30	3.80	2.60	6.90	4.10
			$J_M$	19.32	19.24	19.24	19.24	36.04	36.04	36.04	36.04
5.667	256	3.51	$M_2$	65		59					
			c	3.7		3.2					
			$n_{2 \text{ Eck}}$	289		610					
			$n_{2 \text{ th}}$	289		610					
5.667	299	3.51	$M_2$					118	58	105	51
			c					2.4	4.3	2.1	4.0
			$n_{2 \text{ Eck}}$					297	406	614	725
			$n_{2 \text{ th}}$					296	406	549	549
5.667	465	3.51	$M_2$								
			c								
			$n_{2 \text{ Eck}}$								
			$n_{2 \text{ th}}$								
7.333	265	2.26	$M_2$	85	46	77	37				
			c	3.0	5.0	2.6	4.9				
			$n_{2 \text{ Eck}}$	223	273	471	559				
			$n_{2 \text{ th}}$	223	273	471	490				
7.333	310	2.26	$M_2$					154	76	136	67
			c					1.9	3.4	1.7	3.2
			$n_{2 \text{ Eck}}$					229	314	475	561
			$n_{2 \text{ th}}$					229	314	424	424
8.900	269	1.66	$M_2$	104	57	94	46				
			c	2.5	4.2	2.2	4.1				
			$n_{2 \text{ Eck}}$	184	225	388	461				
			$n_{2 \text{ th}}$	184	225	388	403				
8.900	315	1.66	$M_2$					187	93	166	82
			c					1.6	2.9	1.4	2.7
			$n_{2 \text{ Eck}}$					189	258	391	462
			$n_{2 \text{ th}}$					189	258	350	350
11.250	273	1.11	$M_2$	132	72	119	58				
			c	2.0	3.3	1.7	3.3				
			$n_{2 \text{ Eck}}$	145	178	307	364				
			$n_{2 \text{ th}}$	145	178	307	319				

$M \dots$  [Nm]  
 $n \dots$  [r/min]  
 $J \dots$  [kgcm<sup>2</sup>]

$P \dots$  [kW]  
 $I \dots$  [A]  
 $i$  [-]  
 $c$  [-]

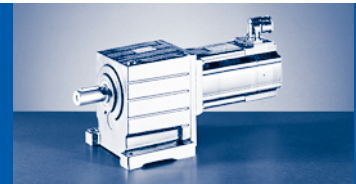

$M_{2GN} \leq 465 \text{ Nm}$

19SC17	19SC23	19SC35	19SC42	21XC17	21XC25	21XC35	21XC42	GST09-1A			
...F10	...500	...F10	...500	...F10	...500	...F10	...500	$M_1$	$J_G$	$M_{2GN}$	$i$
36.30	16.30	36.00	12.00	61.40	24.60	55.00	17.00	$n_1$			
1700	2340	3510	4150	1710	2490	3520	4160	$I_{M400}$			
13.9	8.2	28.7	14.0	22.5	13.5	42.5	19.8	$P_N$			
6.40	4.00	13.20	5.20	11.00	6.40	20.30	7.40	$J_M$			
72.12	72.12	72.04	72.12	180.04	180.04	180.04	180.04	$M_2$ c			
								$n_{2 \text{ Eck}}$ $n_{2 \text{ th}}$	3.51	256	5.667
								$M_2$ c			
								$n_{2 \text{ Eck}}$ $n_{2 \text{ th}}$	3.51	299	5.667
200	88	199	64					$M_2$ c			
2.2	4.4	1.7	5.0					$n_{2 \text{ Eck}}$ $n_{2 \text{ th}}$	3.51	465	5.667
300	413	619	732					$M_2$ c			
300	413	432	432					$n_{2 \text{ Eck}}$ $n_{2 \text{ th}}$	2.26	265	7.333
								$M_2$ c			
								$n_{2 \text{ Eck}}$ $n_{2 \text{ th}}$	2.26	310	7.333
								$M_2$ c			
								$n_{2 \text{ Eck}}$ $n_{2 \text{ th}}$	1.66	269	8.900
								$M_2$ c			
								$n_{2 \text{ Eck}}$ $n_{2 \text{ th}}$	1.66	315	8.900
								$M_2$ c			
								$n_{2 \text{ Eck}}$ $n_{2 \text{ th}}$	1.11	273	11.250

M ... [Nm]  
n ... [r/min]  
J ... [kgcm<sup>2</sup>]

P ... [kW]  
I ... [A]  
i [-]  
c [-]

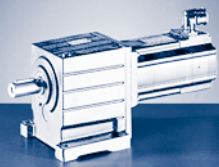

# GST [Nm]

## GST□□-□A (MCA)

$M_{2GN} \leq 1582 \text{ Nm}$

GST09-2A				14LC16	14LC20	14LC35	14LC41	17NC17	17NC23	17NC35	17NC41
				...F10	...S00	...F10	...S00	...F10	...S00	...F10	...S00
i	$M_{2GN}$	$J_G$	$M_1$	12.00	6.70	10.80	5.40	21.50	10.80	19.00	9.50
			$n_1$	1635	2000	3455	4100	1680	2300	3480	4110
			$I_{M400}$	4.8	3.3	9.1	5.8	8.5	5.5	15.8	10.2
			$P_N$	2.10	1.40	3.90	2.30	3.80	2.60	6.90	4.10
			$J_M$	19.32	19.24	19.24	19.24	36.04	36.04	36.04	36.04
4.056	878	27.00	$M_2$ c $n_{2 \text{ Eck}}$ $n_{2 \text{ th}}$								
4.457	931	25.90	$M_2$ c $n_{2 \text{ Eck}}$ $n_{2 \text{ th}}$								
5.324	613	18.10	$M_2$ c $n_{2 \text{ Eck}}$ $n_{2 \text{ th}}$					106 5.3 316 316		94 4.7 654 426	
5.324	993	18.10	$M_2$ c $n_{2 \text{ Eck}}$ $n_{2 \text{ th}}$								
5.850	674	17.50	$M_2$ c $n_{2 \text{ Eck}}$ $n_{2 \text{ th}}$					117 5.3 287 287		104 4.7 595 388	
5.850	1020	17.50	$M_2$ c $n_{2 \text{ Eck}}$ $n_{2 \text{ th}}$								
6.667	690	14.20	$M_2$ c $n_{2 \text{ Eck}}$ $n_{2 \text{ th}}$					134 4.8 252 252		119 4.2 522 365	
6.667	1065	14.20	$M_2$ c $n_{2 \text{ Eck}}$ $n_{2 \text{ th}}$								
7.305	566	11.30	$M_2$ c $n_{2 \text{ Eck}}$ $n_{2 \text{ th}}$			73 5.6 473 398					
7.305	663	11.30	$M_2$ c $n_{2 \text{ Eck}}$ $n_{2 \text{ th}}$					147 4.2 230 230		131 3.7 476 366	
7.305	1103	11.30	$M_2$ c $n_{2 \text{ Eck}}$ $n_{2 \text{ th}}$								
8.027	622	11.00	$M_2$ c $n_{2 \text{ Eck}}$ $n_{2 \text{ th}}$			80 5.6 430 362					
8.027	728	11.00	$M_2$ c $n_{2 \text{ Eck}}$ $n_{2 \text{ th}}$					162 4.2 209 209		144 3.7 434 333	

$M \dots$  [Nm]  
 $n \dots$  [r/min]  
 $J \dots$  [kgcm<sup>2</sup>]

$P \dots$  [kW]  
 $I \dots$  [A]  
 $i$  [-]  
 $c$  [-]

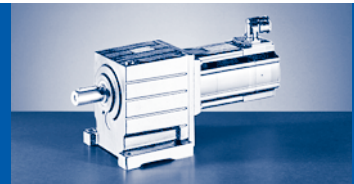

$M_{2GN} \leq 1582 \text{ Nm}$

19SC17	19SC23	19SC35	19SC42	21XC17	21XC25	21XC35	21XC42	GST09-2A			
...F10	...500	...F10	...500	...F10	...500	...F10	...500	$M_1$	$J_G$	$M_{2GN}$	$i$
36.30	16.30	36.00	12.00	61.40	24.60	55.00	17.00	$n_1$			
1700	2340	3510	4150	1710	2490	3520	4160	$I_{M400}$			
13.9	8.2	28.7	14.0	22.5	13.5	42.5	19.8	$P_N$			
6.40	4.00	13.20	5.20	11.00	6.40	20.30	7.40	$J_M$			
72.12	72.12	72.04	72.12	180.04	180.04	180.04	180.04	$M_2$			
136		136		235		212		c	27.00	878	4.056
5.9		4.7		3.5		3.1		$n_{2 \text{ Eck}}$			
419		865		422		868		$n_{2 \text{ th}}$			
419		492		422		446					
149		150		259		233		$M_2$	25.90	931	4.457
5.7		4.5		3.4		3.0		c			
381		788		384		790		$n_{2 \text{ Eck}}$			
381		444		384		403		$n_{2 \text{ th}}$			
								$M_2$	18.10	613	5.324
								c			
								$n_{2 \text{ Eck}}$			
								$n_{2 \text{ th}}$			
180		180		311		279		$M_2$	18.10	993	5.324
5.1		4.0		3.0		2.6		c			
319		659		321		661		$n_{2 \text{ Eck}}$			
319		412		321		375		$n_{2 \text{ th}}$			
								$M_2$	17.50	674	5.850
								c			
								$n_{2 \text{ Eck}}$			
								$n_{2 \text{ th}}$			
198		199		342		307		$M_2$	17.50	1020	5.850
4.8		3.8		2.8		2.5		c			
291		600		292		602		$n_{2 \text{ Eck}}$			
291		370		292		336		$n_{2 \text{ th}}$			
								$M_2$	14.20	690	6.667
								c			
								$n_{2 \text{ Eck}}$			
								$n_{2 \text{ th}}$			
227		227		391	151	351		$M_2$	14.20	1065	6.667
4.4		3.5		2.6	5.7	2.3		c			
255		527		257	374	528		$n_{2 \text{ Eck}}$			
255		349		257	302	302		$n_{2 \text{ th}}$			
								$M_2$	11.30	566	7.305
								c			
								$n_{2 \text{ Eck}}$			
								$n_{2 \text{ th}}$			
								$M_2$	11.30	663	7.305
								c			
								$n_{2 \text{ Eck}}$			
								$n_{2 \text{ th}}$			
249		249		429	167	385		$M_2$	11.30	1103	7.305
4.1		3.3		2.4	5.4	2.1		c			
233		481		234	341	482		$n_{2 \text{ Eck}}$			
233		335		234	276	276		$n_{2 \text{ th}}$			
								$M_2$	11.00	622	8.027
								c			
								$n_{2 \text{ Eck}}$			
								$n_{2 \text{ th}}$			
								$M_2$	11.00	728	8.027
								c			
								$n_{2 \text{ Eck}}$			
								$n_{2 \text{ th}}$			

$M \dots$  [Nm]  
 $n \dots$  [r/min]  
 $J \dots$  [kgcm<sup>2</sup>]

$P \dots$  [kW]  
 $I \dots$  [A]  
 $i$  [-]  
 $c$  [-]

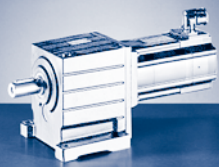

# GST [Nm]

## GST□□-□A (MCA)

$M_{2GN} \leq 1582 \text{ Nm}$

GST09-2A				14LC16	14LC20	14LC35	14LC41	17NC17	17NC23	17NC35	17NC41
				...F10	...S00	...F10	...S00	...F10	...S00	...F10	...S00
i	$M_{2GN}$	$J_G$	$M_1$	12.00	6.70	10.80	5.40	21.50	10.80	19.00	9.50
			$n_1$	1635	2000	3455	4100	1680	2300	3480	4110
			$I_{M400}$	4.8	3.3	9.1	5.8	8.5	5.5	15.8	10.2
			$P_N$	2.10	1.40	3.90	2.30	3.80	2.60	6.90	4.10
			$J_M$	19.32	19.24	19.24	19.24	36.04	36.04	36.04	36.04
8.027	1133	11.00	$M_2$ c $n_{2 \text{ Eck}}$ $n_{2 \text{ th}}$								
9.010	1037	15.20	$M_2$ c $n_{2 \text{ Eck}}$ $n_{2 \text{ th}}$					180 5.3 187 186		160 4.7 386 252	
9.010	1128	15.20	$M_2$ c $n_{2 \text{ Eck}}$ $n_{2 \text{ th}}$								
10.267	1063	12.40	$M_2$ c $n_{2 \text{ Eck}}$ $n_{2 \text{ th}}$					206 4.8 164 164		183 4.2 339 237	
10.267	1178	12.40	$M_2$ c $n_{2 \text{ Eck}}$ $n_{2 \text{ th}}$								
11.667	1206	12.10	$M_2$ c $n_{2 \text{ Eck}}$ $n_{2 \text{ th}}$					234 4.8 144 144		208 4.2 298 208	
12.362	958	9.79	$M_2$ c $n_{2 \text{ Eck}}$ $n_{2 \text{ th}}$			123 5.6 280 235					
12.362	1121	9.79	$M_2$ c $n_{2 \text{ Eck}}$ $n_{2 \text{ th}}$					249 4.2 136 136		222 3.7 282 216	
12.362	1253	9.79	$M_2$ c $n_{2 \text{ Eck}}$ $n_{2 \text{ th}}$								
14.048	1088	9.53	$M_2$ c $n_{2 \text{ Eck}}$ $n_{2 \text{ th}}$			140 5.6 246 207					
14.048	1274	9.53	$M_2$ c $n_{2 \text{ Eck}}$ $n_{2 \text{ th}}$					283 4.2 120 120		252 3.7 248 190	
14.048	1283	9.53	$M_2$ c $n_{2 \text{ Eck}}$ $n_{2 \text{ th}}$								
15.156	1179	7.65	$M_2$ c $n_{2 \text{ Eck}}$ $n_{2 \text{ th}}$					307 3.7 111 111		272 3.6 230 191	

$M \dots$  [Nm]  
 $n \dots$  [r/min]  
 $J \dots$  [kgcm<sup>2</sup>]

$P \dots$  [kW]  
 $I \dots$  [A]  
 $i$  [-]  
 $c$  [-]

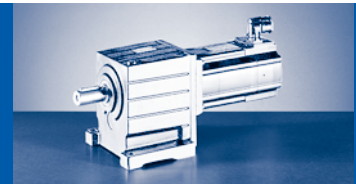

$M_{2GN} \leq 1582 \text{ Nm}$

19SC17	19SC23	19SC35	19SC42	21XC17	21XC25	21XC35	21XC42	GST09-2A			
...F10	...500	...F10	...500	...F10	...500	...F10	...500	$M_1$	$J_G$	$M_{2GN}$	$i$
36.30	16.30	36.00	12.00	61.40	24.60	55.00	17.00	$n_1$			
1700	2340	3510	4150	1710	2490	3520	4160	$l_{M400}$			
13.9	8.2	28.7	14.0	22.5	13.5	42.5	19.8	$P_N$			
6.40	4.00	13.20	5.20	11.00	6.40	20.30	7.40	$J_M$			
72.12	72.12	72.04	72.12	180.04	180.04	180.04	180.04	$M_2$			
274		274		472	184	424		$c$	11.00	1133	8.027
3.8		3.0		2.3	5.0	2.0		$n_{2 \text{ Eck}}$			
212		437		213	310	439		$n_{2 \text{ th}}$			
212		305		213	251	251		$M_2$			
								$c$	15.20	1037	9.010
								$n_{2 \text{ Eck}}$			
								$n_{2 \text{ th}}$			
309		309		531	207	477	142	$M_2$	15.20	1128	9.010
3.4		2.7		2.0	4.4	1.8	5.4	$c$			
189		390		190	276	391	462	$n_{2 \text{ Eck}}$			
189		223		190	223	194	223	$n_{2 \text{ th}}$			
								$M_2$			
								$c$	12.40	1063	10.267
								$n_{2 \text{ Eck}}$			
								$n_{2 \text{ th}}$			
354		353		606	237	544	162	$M_2$	12.40	1178	10.267
3.1		2.5		1.8	4.1	1.6	5.0	$c$			
166		342		167	243	343	405	$n_{2 \text{ Eck}}$			
166		210		167	196	177	196	$n_{2 \text{ th}}$			
403	176	402		690	271	620	186	$M_2$	12.10	1206	11.667
2.8	5.6	2.2		1.7	3.7	1.5	4.5	$c$			
146	201	301		147	213	302	357	$n_{2 \text{ Eck}}$			
146	201	180		147	173	147	173	$n_{2 \text{ th}}$			
								$M_2$			
								$c$	9.79	958	12.362
								$n_{2 \text{ Eck}}$			
								$n_{2 \text{ th}}$			
								$M_2$			
								$c$	9.79	1121	12.362
								$n_{2 \text{ Eck}}$			
								$n_{2 \text{ th}}$			
427	186	427		732	287	657	197	$M_2$	9.79	1253	12.362
2.8	5.5	2.2		1.6	3.6	1.4	4.4	$c$			
138	189	284		138	201	285	337	$n_{2 \text{ Eck}}$			
138	189	192		138	163	155	163	$n_{2 \text{ th}}$			
								$M_2$			
								$c$	9.53	1088	14.048
								$n_{2 \text{ Eck}}$			
								$n_{2 \text{ th}}$			
								$M_2$			
								$c$	9.53	1274	14.048
								$n_{2 \text{ Eck}}$			
								$n_{2 \text{ th}}$			
487	213	486	156	833	328	747	225	$M_2$	9.53	1283	14.048
2.5	5.0	2.0	5.6	1.5	3.2	1.3	3.9	$c$			
121	167	250	295	122	177	251	296	$n_{2 \text{ Eck}}$			
121	167	165	174	122	143	129	143	$n_{2 \text{ th}}$			
								$M_2$			
								$c$	7.65	1179	15.156
								$n_{2 \text{ Eck}}$			
								$n_{2 \text{ th}}$			

$M \dots$  [Nm]  
 $n \dots$  [r/min]  
 $J \dots$  [kgcm<sup>2</sup>]

$P \dots$  [kW]  
 $I \dots$  [A]  
 $i$  [-]  
 $c$  [-]

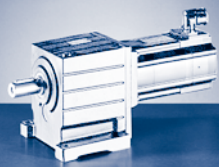

# GST [Nm]

## GST□□-□A (MCA)

$M_{2GN} \leq 1582 \text{ Nm}$

GST09-2A				14LC16	14LC20	14LC35	14LC41	17NC17	17NC23	17NC35	17NC41
i	$M_{2GN}$	$J_G$	$M_1$	...F10	...S00	...F10	...S00	...F10	...S00	...F10	...S00
			$n_1$	12.00	6.70	10.80	5.40	21.50	10.80	19.00	9.50
			$I_{M400}$	1635	2000	3455	4100	1680	2300	3480	4110
			$P_N$	4.8	3.3	9.1	5.8	8.5	5.5	15.8	10.2
			$J_M$	2.10	1.40	3.90	2.30	3.80	2.60	6.90	4.10
			$M_2$	19.32	19.24	19.24	19.24	36.04	36.04	36.04	36.04
15.156	1340	7.65	c								
			$n_{2 \text{ Eck}}$								
			$n_{2 \text{ th}}$								
17.222	1340	7.49	$M_2$					349		309	
			c					3.7		3.6	
			$n_{2 \text{ Eck}}$					98		202	
			$n_{2 \text{ th}}$					98		168	
17.222	1373	7.49	$M_2$								
			c								
			$n_{2 \text{ Eck}}$								
			$n_{2 \text{ th}}$								
20.533	1068	4.50	$M_2$	231		208					
			c	4.5		4.3					
			$n_{2 \text{ Eck}}$	80		168					
			$n_{2 \text{ th}}$	80		168					
20.533	1251	4.50	$M_2$					420	205	371	181
			c					2.9	5.7	2.8	5.4
			$n_{2 \text{ Eck}}$					82	112	170	200
			$n_{2 \text{ th}}$					82	112	152	152
20.533	1484	4.50	$M_2$								
			c								
			$n_{2 \text{ Eck}}$								
			$n_{2 \text{ th}}$								
23.333	1214	4.41	$M_2$	262		236					
			c	4.5		4.3					
			$n_{2 \text{ Eck}}$	70		148					
			$n_{2 \text{ th}}$	70		148					
23.333	1421	4.41	$M_2$					477	233	422	205
			c					2.9	5.7	2.8	5.4
			$n_{2 \text{ Eck}}$					72	99	149	176
			$n_{2 \text{ th}}$					72	99	133	133
23.333	1508	4.41	$M_2$								
			c								
			$n_{2 \text{ Eck}}$								
			$n_{2 \text{ th}}$								
24.933	1107	3.38	$M_2$	282		254					
			c	3.8		3.7					
			$n_{2 \text{ Eck}}$	66		139					
			$n_{2 \text{ th}}$	66		139					
24.933	1296	3.38	$M_2$					512	251	453	221
			c					2.5	4.9	2.4	4.6
			$n_{2 \text{ Eck}}$					67	92	140	165
			$n_{2 \text{ th}}$					67	92	125	125
24.933	1582	3.38	$M_2$								
			c								
			$n_{2 \text{ Eck}}$								
			$n_{2 \text{ th}}$								
28.333	1258	3.32	$M_2$	320		289					
			c	3.8		3.7					
			$n_{2 \text{ Eck}}$	58		122					
			$n_{2 \text{ th}}$	58		122					

$M \dots$  [Nm]  
 $n \dots$  [r/min]  
 $J \dots$  [kgcm<sup>2</sup>]

$P \dots$  [kW]  
 $I \dots$  [A]  
 $i$  [-]  
 $c$  [-]

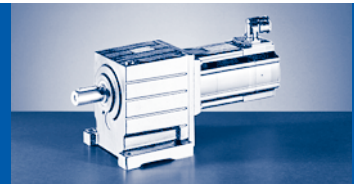

$M_{2GN} \leq 1582 \text{ Nm}$

195C17	195C23	195C35	195C42	21XC17	21XC25	21XC35	21XC42	GST09-2A			
...F10	...500	...F10	...500	...F10	...500	...F10	...500	$M_1$	$J_G$	$M_{2GN}$	$i$
36.30	16.30	36.00	12.00	61.40	24.60	55.00	17.00	$n_1$			
1700	2340	3510	4150	1710	2490	3520	4160	$l_{M400}$			
13.9	8.2	28.7	14.0	22.5	13.5	42.5	19.8	$P_N$			
6.40	4.00	13.20	5.20	11.00	6.40	20.30	7.40	$J_M$			
72.12	72.12	72.04	72.12	180.04	180.04	180.04	180.04	$M_2$			
525	229	523		898	352	805	241	$c$	7.65	1340	15.156
2.5	5.5	2.2		1.5	3.6	1.4	4.3	$n_{2 \text{ Eck}}$			
112	154	232		113	164	232	275	$n_{2 \text{ th}}$			
112	154	162		113	133	133	133				
								$M_2$			
								$c$	7.49	1340	17.222
								$n_{2 \text{ Eck}}$			
								$n_{2 \text{ th}}$			
599	261	596	191	1022	402	916	276	$M_2$			
2.3	4.9	2.0	5.5	1.3	3.2	1.3	3.9	$c$	7.49	1373	17.222
99	136	204	241	99	145	204	242	$n_{2 \text{ Eck}}$			
99	136	142	142	99	117	117	117	$n_{2 \text{ th}}$			
								$M_2$			
								$c$	4.50	1068	20.533
								$n_{2 \text{ Eck}}$			
								$n_{2 \text{ th}}$			
								$M_2$			
								$c$	4.50	1251	20.533
								$n_{2 \text{ Eck}}$			
								$n_{2 \text{ th}}$			
715	313	711	229					$M_2$			
2.1	4.5	1.8	5.0					$c$	4.50	1484	20.533
83	114	171	202					$n_{2 \text{ Eck}}$			
83	114	119	119					$n_{2 \text{ th}}$			
								$M_2$			
								$c$	4.41	1214	23.333
								$n_{2 \text{ Eck}}$			
								$n_{2 \text{ th}}$			
								$M_2$			
								$c$	4.41	1421	23.333
								$n_{2 \text{ Eck}}$			
								$n_{2 \text{ th}}$			
815	358	810	262					$M_2$			
1.8	4.0	1.6	4.5					$c$	4.41	1508	23.333
73	100	150	178					$n_{2 \text{ Eck}}$			
73	100	105	105					$n_{2 \text{ th}}$			
								$M_2$			
								$c$	3.38	1107	24.933
								$n_{2 \text{ Eck}}$			
								$n_{2 \text{ th}}$			
								$M_2$			
								$c$	3.38	1296	24.933
								$n_{2 \text{ Eck}}$			
								$n_{2 \text{ th}}$			
871	382	866	280					$M_2$			
1.8	3.9	1.6	4.4					$c$	3.38	1582	24.933
68	94	141	166					$n_{2 \text{ Eck}}$			
68	94	98	98					$n_{2 \text{ th}}$			
								$M_2$			
								$c$	3.32	1258	28.333
								$n_{2 \text{ Eck}}$			
								$n_{2 \text{ th}}$			

$M \dots$  [Nm]  
 $n \dots$  [r/min]  
 $J \dots$  [kgcm<sup>2</sup>]

$P \dots$  [kW]  
 $I \dots$  [A]  
 $i$  [-]  
 $c$  [-]

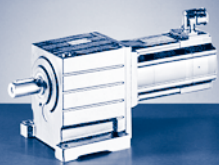

# GST [Nm]

## GST□□-□A (MCA)

$M_{2GN} \leq 1582 \text{ Nm}$

GST09-2A				14LC16	14LC20	14LC35	14LC41	17NC17	17NC23	17NC35	17NC41
				...F10	...S00	...F10	...S00	...F10	...S00	...F10	...S00
i	$M_{2GN}$	$J_G$	$M_1$	12.00	6.70	10.80	5.40	21.50	10.80	19.00	9.50
			$n_1$	1635	2000	3455	4100	1680	2300	3480	4110
			$I_{M400}$	4.8	3.3	9.1	5.8	8.5	5.5	15.8	10.2
			$P_N$	2.10	1.40	3.90	2.30	3.80	2.60	6.90	4.10
			$J_M$	19.32	19.24	19.24	19.24	36.04	36.04	36.04	36.04
28.333	1472	3.32	$M_2$					582	285	515	252
			c					2.5	4.9	2.4	4.6
			$n_{2 \text{ Eck}}$					59	81	123	145
			$n_{2 \text{ th}}$					59	81	110	110
28.333	1519	3.32	$M_2$								
			c								
			$n_{2 \text{ Eck}}$								
			$n_{2 \text{ th}}$								
32.267	1147	2.25	$M_2$	368	200	331	161				
			c	3.1	5.5	2.9	5.5				
			$n_{2 \text{ Eck}}$	51	62	107	127				
			$n_{2 \text{ th}}$	51	62	107	111				
32.267	1343	2.25	$M_2$					666	328	589	289
			c					2.0	3.9	1.9	3.7
			$n_{2 \text{ Eck}}$					52	71	108	127
			$n_{2 \text{ th}}$					52	71	96	96
36.667	1304	2.21	$M_2$	418	227	377	183				
			c	3.1	5.5	2.9	5.5				
			$n_{2 \text{ Eck}}$	45	55	94	112				
			$n_{2 \text{ th}}$	45	55	94	98				
36.667	1526	2.21	$M_2$					757	373	669	329
			c					2.0	3.9	1.9	3.7
			$n_{2 \text{ Eck}}$					46	63	95	112
			$n_{2 \text{ th}}$					46	63	85	85
39.160	1166	1.64	$M_2$	449	245	404	198				
			c	2.6	4.6	2.4	4.6				
			$n_{2 \text{ Eck}}$	42	51	88	105				
			$n_{2 \text{ th}}$	42	51	88	92				
39.160	1364	1.64	$M_2$					811	401	717	353
			c					1.7	3.3	1.6	3.1
			$n_{2 \text{ Eck}}$					43	59	89	105
			$n_{2 \text{ th}}$					43	59	79	79
44.500	1324	1.62	$M_2$	510	279	458	223				
			c	2.6	4.6	2.7	5.1				
			$n_{2 \text{ Eck}}$	37	45	78	92				
			$n_{2 \text{ th}}$	37	45	78	81				
44.500	1546	1.62	$M_2$					922	455	814	400
			c					1.7	3.3	1.8	3.4
			$n_{2 \text{ Eck}}$					38	52	78	92
			$n_{2 \text{ th}}$					38	52	70	70
49.500	1184	1.12	$M_2$	570	313	512	251				
			c	2.1	3.7	2.2	4.1				
			$n_{2 \text{ Eck}}$	33	40	70	83				
			$n_{2 \text{ th}}$	33	40	70	73				
56.250	1345	1.10	$M_2$	648	356	582	285				
			c	2.1	3.7	2.2	4.1				
			$n_{2 \text{ Eck}}$	29	36	61	73				
			$n_{2 \text{ th}}$	29	36	61	64				

$M \dots$  [Nm]  
 $n \dots$  [r/min]  
 $J \dots$  [kgcm<sup>2</sup>]

$P \dots$  [kW]  
 $I \dots$  [A]  
 $i$  [-]  
 $c$  [-]

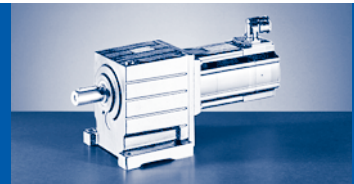

$M_{2GN} \leq 1582 \text{ Nm}$

19SC17	19SC23	19SC35	19SC42	21XC17	21XC25	21XC35	21XC42	GST09-2A			
...F10	...500	...F10	...500	...F10	...500	...F10	...500	$M_1$	$J_G$	$M_{2GN}$	$i$
36.30	16.30	36.00	12.00	61.40	24.60	55.00	17.00	$n_1$			
1700	2340	3510	4150	1710	2490	3520	4160	$I_{M400}$			
13.9	8.2	28.7	14.0	22.5	13.5	42.5	19.8	$P_N$			
6.40	4.00	13.20	5.20	11.00	6.40	20.30	7.40	$J_M$			
72.12	72.12	72.04	72.12	180.04	180.04	180.04	180.04	$M_2$ c			
								$n_2$ Eck	3.32	1472	28.333
								$n_2$ th			
993	437	986	321					$M_2$ c			
1.5	3.3	1.3	3.7					$n_2$ Eck	3.32	1519	28.333
60	83	124	147					$n_2$ th			
60	83	86	86					$M_2$ c			
								$n_2$ Eck	2.25	1147	32.267
								$n_2$ th			
								$M_2$ c			
								$n_2$ Eck	2.25	1343	32.267
								$n_2$ th			
								$M_2$ c			
								$n_2$ Eck	2.21	1304	36.667
								$n_2$ th			
								$M_2$ c			
								$n_2$ Eck	2.21	1526	36.667
								$n_2$ th			
								$M_2$ c			
								$n_2$ Eck	1.64	1166	39.160
								$n_2$ th			
								$M_2$ c			
								$n_2$ Eck	1.64	1364	39.160
								$n_2$ th			
								$M_2$ c			
								$n_2$ Eck	1.62	1324	44.500
								$n_2$ th			
								$M_2$ c			
								$n_2$ Eck	1.62	1546	44.500
								$n_2$ th			
								$M_2$ c			
								$n_2$ Eck	1.12	1184	49.500
								$n_2$ th			
								$M_2$ c			
								$n_2$ Eck	1.10	1345	56.250
								$n_2$ th			

M ... [Nm]  
n ... [r/min]  
J ... [kgcm<sup>2</sup>]

P ... [kW]  
I ... [A]  
i [-]  
c [-]

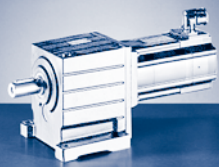

# GST [Nm]

## GST□□-□A (MCA)

$M_{2GN} \leq 1623 \text{ Nm}$

GST09-3A				10IC40	13IC34	13IC41	14LC16	14LC20	14LC35	14LC41	17NC17	17NC23	17NC35	17NC41	
				...S00	...F10	...S00	...F10	...S00	...F10	...S00	...F10	...S00	...F10	...S00	
i	$M_{2GN}$	$J_G$	$M_1$	2.00	6.30	4.00	12.00	6.70	10.80	5.40	21.50	10.80	19.00	9.50	
			$n_1$	3950	3410	4050	1635	2000	3455	4100	1680	2300	3480	4110	
			$I_{M400}$	2.4	6.0	4.4	4.8	3.3	9.1	5.8	8.5	5.5	15.8	10.2	
			$P_N$	0.80	2.20	1.70	2.10	1.40	3.90	2.30	3.80	2.60	6.90	4.10	
			$J_M$	2.44	8.34	8.34	19.32	19.24	19.24	19.24	36.04	36.04	36.04	36.04	
40.136	1344	2.14	$M_2$		232		451	246	406	198	819	405	724	357	
			c		4.8		2.9	5.2	2.8	5.3	1.6	3.2	1.6	3.0	
			$n_{2 \text{ Eck}}$		85		41	50	86	102	42	57	87	102	102
			$n_{2 \text{ th}}$		85		41	50	86	89	42	57	78	78	78
43.267	1290	1.55	$M_2$		250		488	266	438	213	885	438	781	385	
			c		4.7		2.6	4.7	2.8	5.2	1.5	2.9	1.6	3.0	
			$n_{2 \text{ Eck}}$		79		38	46	80	95	39	53	80	95	
			$n_{2 \text{ th}}$		79		38	46	80	83	39	53	72	72	
49.167	1466	1.53	$M_2$		284		554	303	498	243	1005	497	888	437	
			c		4.7		2.6	4.7	2.8	5.2	1.5	2.9	1.6	3.0	
			$n_{2 \text{ Eck}}$		69		33	41	70	83	34	47	71	84	
			$n_{2 \text{ th}}$		69		33	41	70	73	34	47	63	63	
53.044	1379	1.38	$M_2$		309		600	329	539	264	1087	539	960	474	
			c		4.1		2.3	4.1	2.4	4.5	1.3	2.5	1.4	2.6	
			$n_{2 \text{ Eck}}$		64		31	38	65	77	32	43	66	78	
			$n_{2 \text{ th}}$		64		31	38	65	68	32	43	59	59	
60.278	1565	1.37	$M_2$		351		682	374	613	300	1235	612	1090	538	
			c		4.1		2.3	4.1	2.4	4.5	1.3	2.5	1.4	2.6	
			$n_{2 \text{ Eck}}$		57		27	33	57	68	28	38	58	68	
			$n_{2 \text{ th}}$		57		27	33	57	60	28	38	52	52	
71.867	1477	1.17	$M_2$		422	264	817	450	735	361	1477	734	1304	645	
			c		3.3	4.9	1.8	3.2	1.9	3.6	1.0	2.0	1.1	2.0	
			$n_{2 \text{ Eck}}$		48	56	23	28	48	57	23	32	48	57	
			$n_{2 \text{ th}}$		47	56	23	28	48	50	23	32	43	43	
81.667	1584	1.16	$M_2$		481	300	930	512	836	411		835	1483	734	
			c		3.1	4.6	1.7	3.0	1.8	3.4		1.9	1.0	1.9	
			$n_{2 \text{ Eck}}$		42	50	20	25	42	50		28	43	50	
			$n_{2 \text{ th}}$		42	50	20	24	42	44		28	38	38	
93.541	1613	0.71	$M_2$		553	346	1067	588	959	473					
			c		2.7	4.1	1.5	2.7	1.6	3.0					
			$n_{2 \text{ Eck}}$		37	43	18	21	37	44					
			$n_{2 \text{ th}}$		36	43	17	21	37	38					
99.167	1596	1.07	$M_2$		587	368	1132	625	1018	502		1018		895	
			c		2.6	3.8	1.4	2.5	1.5	2.8		1.6		1.6	
			$n_{2 \text{ Eck}}$		34	41	17	20	35	41		23		42	
			$n_{2 \text{ th}}$		34	41	16	20	35	36		23		31	
113.585	1613	0.65	$M_2$		675	423	1299	718	1169	577					
			c		2.3	3.4	1.2	2.2	1.3	2.5					
			$n_{2 \text{ Eck}}$		30	36	14	18	30	36					
			$n_{2 \text{ th}}$		30	36	14	18	30	32					
129.074	1612	0.65	$M_2$	234	769	483	1479	818	1330	658					
			c	6.0	2.0	3.0	1.1	2.0	1.2	2.2					
			$n_{2 \text{ Eck}}$	31	26	31	13	16	27	32					
			$n_{2 \text{ th}}$	31	26	31	13	15	27	28					
141.289	1613	0.46	$M_2$	257	843	530		897	1457	722					
			c	5.5	1.8	2.7		1.8	1.1	2.0					
			$n_{2 \text{ Eck}}$	28	24	29		14	25	29					
			$n_{2 \text{ th}}$	28	24	29		14	24	25					
160.556	1623	0.46	$M_2$	295	961	605		1022		822					
			c	4.8	1.6	2.4		1.6		1.8					
			$n_{2 \text{ Eck}}$	25	21	25		13		26					
			$n_{2 \text{ th}}$	25	21	25		12		22					

$M \dots$  [Nm]  
 $n \dots$  [r/min]  
 $J \dots$  [kgcm<sup>2</sup>]

$P \dots$  [kW]  
 $I \dots$  [A]  
 $i [-]$   
 $c [-]$

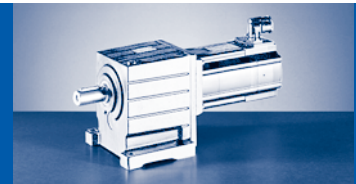

$M_{2GN} \leq 1623 \text{ Nm}$

GST09-3A				10IC40	13IC34	13IC41	14LC16	14LC20	14LC35	14LC41	17NC17	17NC23	17NC35	17NC41	
				...S00	...F10	...S00	...F10	...S00	...F10	...S00	...F10	...S00	...F10	...S00	
i	$M_{2GN}$	$J_G$	$M_1$	2.00	6.30	4.00	12.00	6.70	10.80	5.40	21.50	10.80	19.00	9.50	
			$n_1$	3950	3410	4050	1635	2000	3455	4100	1680	2300	3480	4110	
			$I_{M400}$	2.4	6.0	4.4	4.8	3.3	9.1	5.8	8.5	5.5	15.8	10.2	
			$P_N$	0.80	2.20	1.70	2.10	1.40	3.90	2.30	3.80	2.60	6.90	4.10	
			$J_M$	2.44	8.34	8.34	19.32	19.24	19.24	19.24	36.04	36.04	36.04	36.04	
182.844	1613	0.30	$M_2$	338	1096	691									
			c	4.2	1.4	2.1									
			$n_{2 \text{ Eck}}$	22	19	22									
			$n_{2 \text{ th}}$	22	19	22									
207.778	1623	0.30	$M_2$	386	1248	787									
			c	3.7	1.2	1.9									
			$n_{2 \text{ Eck}}$	19	16	20									
			$n_{2 \text{ th}}$	19	16	19									
236.622	1613	0.28	$M_2$	442	1423	899									
			c	3.3	1.1	1.6									
			$n_{2 \text{ Eck}}$	17	14	17									
			$n_{2 \text{ th}}$	17	14	17									
252.167	1623	0.21	$M_2$	472	1518	959									
			c	3.1	1.0	1.5									
			$n_{2 \text{ Eck}}$	16	14	16									
			$n_{2 \text{ th}}$	16	14	16									
268.889	1623	0.28	$M_2$	504		1023									
			c	2.9		1.4									
			$n_{2 \text{ Eck}}$	15		15									
			$n_{2 \text{ th}}$	15		15									
326.333	1623	0.20	$M_2$	615		1245									
			c	2.4		1.2									
			$n_{2 \text{ Eck}}$	12		12									
			$n_{2 \text{ th}}$	12		12									
363.000	1613	0.26	$M_2$	686											
			c	2.1											
			$n_{2 \text{ Eck}}$	11											
			$n_{2 \text{ th}}$	11											
412.500	1623	0.18	$M_2$	781											
			c	1.9											
			$n_{2 \text{ Eck}}$	10											
			$n_{2 \text{ th}}$	10											

M ... [Nm]  
n ... [r/min]  
J ... [kgcm<sup>2</sup>]

P ... [kW]  
I ... [A]  
i [-]  
c [-]

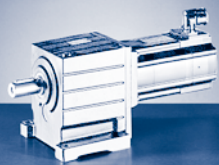

# GST [Nm]

## GST□□-□A (MCA)

$M_{2GN} \leq 2933 \text{ Nm}$

GST11-2A				14LC16	14LC20	14LC35	14LC41	17NC17	17NC23	17NC35	17NC41
				...F10	...S00	...F10	...S00	...F10	...S00	...F10	...S00
i	$M_{2GN}$	$J_G$	$M_1$	12.00	6.70	10.80	5.40	21.50	10.80	19.00	9.50
			$n_1$	1635	2000	3455	4100	1680	2300	3480	4110
			$I_{M400}$	4.8	3.3	9.1	5.8	8.5	5.5	15.8	10.2
			$P_N$	2.10	1.40	3.90	2.30	3.80	2.60	6.90	4.10
			$J_M$	19.32	19.24	19.24	19.24	36.04	36.04	36.04	36.04
4.056	1490	82.20	$M_2$ c $n_{2 \text{ Eck}}$ $n_{2 \text{ th}}$								
4.457	1606	79.00	$M_2$ c $n_{2 \text{ Eck}}$ $n_{2 \text{ th}}$								
5.324	1594	55.40	$M_2$ c $n_{2 \text{ Eck}}$ $n_{2 \text{ th}}$								
5.850	1772	53.50	$M_2$ c $n_{2 \text{ Eck}}$ $n_{2 \text{ th}}$								
6.400	1549	45.70	$M_2$ c $n_{2 \text{ Eck}}$ $n_{2 \text{ th}}$								
6.400	1801	45.70	$M_2$ c $n_{2 \text{ Eck}}$ $n_{2 \text{ th}}$								
6.864	2065	67.50	$M_2$ c $n_{2 \text{ Eck}}$ $n_{2 \text{ th}}$								
7.800	2114	65.10	$M_2$ c $n_{2 \text{ Eck}}$ $n_{2 \text{ th}}$								
9.010	2259	46.80	$M_2$ c $n_{2 \text{ Eck}}$ $n_{2 \text{ th}}$								
9.856	2325	40.20	$M_2$ c $n_{2 \text{ Eck}}$ $n_{2 \text{ th}}$								
11.200	2380	39.00	$M_2$ c $n_{2 \text{ Eck}}$ $n_{2 \text{ th}}$								
12.571	1414	29.40	$M_2$ c $n_{2 \text{ Eck}}$ $n_{2 \text{ th}}$					251 5.2 134 134		223 4.6 277 180	
12.571	2520	29.40	$M_2$ c $n_{2 \text{ Eck}}$ $n_{2 \text{ th}}$								

$M \dots$  [Nm]  
 $n \dots$  [r/min]  
 $J \dots$  [kgcm<sup>2</sup>]

$P \dots$  [kW]  
 $I \dots$  [A]  
 $i$  [-]  
 $c$  [-]

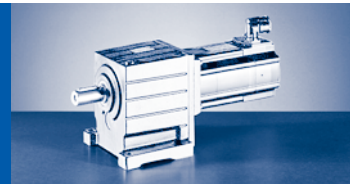

$M_{2GN} \leq 2933 \text{ Nm}$

19SC17	19SC23	19SC35	19SC42	21XC17	21XC25	21XC35	21XC42	GST11-2A			
...F10	...500	...F10	...500	...F10	...500	...F10	...500	$M_1$	$J_G$	$M_{2GN}$	$i$
36.30	16.30	36.00	12.00	61.40	24.60	55.00	17.00	$n_1$			
1700	2340	3510	4150	1710	2490	3520	4160	$I_{M400}$			
13.9	8.2	28.7	14.0	22.5	13.5	42.5	19.8	$P_N$			
6.40	4.00	13.20	5.20	11.00	6.40	20.30	7.40	$J_M$			
72.12	72.12	72.04	72.12	180.04	180.04	180.04	180.04	$M_2$			
				229		207		c	82.20	1490	4.056
				5.9		5.2		$n_{2 \text{ Eck}}$			
				422		868		$n_{2 \text{ th}}$			
				422		421		$n_{2 \text{ th}}$			
				252		228		$M_2$	79.00	1606	4.457
				5.8		5.1		c			
				384		790		$n_{2 \text{ Eck}}$			
				384		382		$n_{2 \text{ th}}$			
				305		275		$M_2$	55.40	1594	5.324
				4.8		4.2		c			
				321		661		$n_{2 \text{ Eck}}$			
				321		356		$n_{2 \text{ th}}$			
				335		302		$M_2$	53.50	1772	5.850
				4.9		4.3		c			
				292		602		$n_{2 \text{ Eck}}$			
				292		325		$n_{2 \text{ th}}$			
		214						$M_2$	45.70	1549	6.400
		5.2						c			
		548						$n_{2 \text{ Eck}}$			
		320						$n_{2 \text{ th}}$			
				367		331		$M_2$	45.70	1801	6.400
				4.5		4.0		c			
				267		550		$n_{2 \text{ Eck}}$			
				267		302		$n_{2 \text{ th}}$			
				393		354		$M_2$	67.50	2065	6.864
				4.8		4.2		c			
				249		513		$n_{2 \text{ Eck}}$			
				245		238		$n_{2 \text{ th}}$			
				449		404		$M_2$	65.10	2114	7.800
				4.4		3.8		c			
				219		451		$n_{2 \text{ Eck}}$			
				211		204		$n_{2 \text{ th}}$			
				520		468		$M_2$	46.80	2259	9.010
				4.0		3.5		c			
				190		391		$n_{2 \text{ Eck}}$			
				190		202		$n_{2 \text{ th}}$			
		330		570		513		$M_2$	40.20	2325	9.856
		5.1		3.8		3.3		c			
		356		174		357		$n_{2 \text{ Eck}}$			
		207		174		188		$n_{2 \text{ th}}$			
375		377		651		585		$M_2$	39.00	2380	11.200
5.8		4.6		3.4		3.0		c			
152		313		153		314		$n_{2 \text{ Eck}}$			
152		178		153		161		$n_{2 \text{ th}}$			
								$M_2$	29.40	1414	12.571
								c			
								$n_{2 \text{ Eck}}$			
								$n_{2 \text{ th}}$			
422		424		732		658		$M_2$	29.40	2520	12.571
5.5		4.3		3.2		2.8		c			
135		279		136		280		$n_{2 \text{ Eck}}$			
135		178		136		160		$n_{2 \text{ th}}$			

M ... [Nm]  
n ... [r/min]  
J ... [kgcm<sup>2</sup>]

P ... [kW]  
I ... [A]  
i [-]  
c [-]

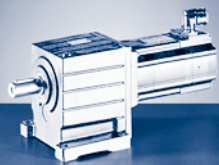

# GST [Nm]

## GST□□-□A (MCA)

$M_{2GN} \leq 2933 \text{ Nm}$

GST11-2A				14LC16	14LC20	14LC35	14LC41	17NC17	17NC23	17NC35	17NC41
i	$M_{2GN}$	$J_G$	$M_1$	...F10	...S00	...F10	...S00	...F10	...S00	...F10	...S00
			$n_1$	12.00	6.70	10.80	5.40	21.50	10.80	19.00	9.50
			$I_{M400}$	1635	2000	3455	4100	1680	2300	3480	4110
			$P_N$	4.8	3.3	9.1	5.8	8.5	5.5	15.8	10.2
			$J_M$	2.10	1.40	3.90	2.30	3.80	2.60	6.90	4.10
			$M_2$	19.32	19.24	19.24	19.24	36.04	36.04	36.04	36.04
			c					285		254	
14.286	1607	28.70	$n_{2 \text{ Eck}}$					5.2		4.6	
			$n_{2 \text{ th}}$					118		244	
			$M_2$					118		159	
			c								
14.286	2579	28.70	$n_{2 \text{ Eck}}$								
			$n_{2 \text{ th}}$								
			$M_2$								
			c								
15.400	2695	23.00	$n_{2 \text{ Eck}}$								
			$n_{2 \text{ th}}$								
			$M_2$								
			c								
17.500	2758	22.50	$n_{2 \text{ Eck}}$								
			$n_{2 \text{ th}}$								
			$M_2$								
			c								
20.289	1570	14.30	$n_{2 \text{ Eck}}$					411		364	
			$n_{2 \text{ th}}$					3.7		3.6	
			$M_2$					83		172	
			c					83		143	
			$n_{2 \text{ Eck}}$								
			$n_{2 \text{ th}}$								
			$M_2$								
			c								
20.289	2756	14.30	$n_{2 \text{ Eck}}$								
			$n_{2 \text{ th}}$								
			$M_2$								
			c								
23.056	1784	14.10	$n_{2 \text{ Eck}}$					468		414	
			$n_{2 \text{ th}}$					3.7		3.6	
			$M_2$					73		151	
			c					73		125	
			$n_{2 \text{ Eck}}$								
			$n_{2 \text{ th}}$								
			$M_2$								
			c								
23.056	2913	14.10	$n_{2 \text{ Eck}}$								
			$n_{2 \text{ th}}$								
			$M_2$								
			c								
24.933	1616	10.60	$n_{2 \text{ Eck}}$					509		450	219
			$n_{2 \text{ th}}$					3.1		3.0	5.7
			$M_2$					67		140	165
			c					67		125	125
			$n_{2 \text{ Eck}}$								
			$n_{2 \text{ th}}$								
			$M_2$								
			c								
24.933	2777	10.60	$n_{2 \text{ Eck}}$								
			$n_{2 \text{ th}}$								
			$M_2$								
			c								
28.333	1836	10.40	$n_{2 \text{ Eck}}$					578		511	248
			$n_{2 \text{ th}}$					3.1		3.0	5.7
			$M_2$					59		123	145
			c					59		110	110
			$n_{2 \text{ Eck}}$								
			$n_{2 \text{ th}}$								
			$M_2$								
			c								
28.333	2933	10.40	$n_{2 \text{ Eck}}$								
			$n_{2 \text{ th}}$								
			$M_2$								
			c								
32.267	1430	7.04	$n_{2 \text{ Eck}}$	365		329					
			$n_{2 \text{ th}}$	3.8		3.6					
			$M_2$	51		107					
			c	51		107					

$M \dots$  [Nm]  
 $n \dots$  [r/min]  
 $J \dots$  [kgcm<sup>2</sup>]

$P \dots$  [kW]  
 $I \dots$  [A]  
 $i$  [-]  
 $c$  [-]

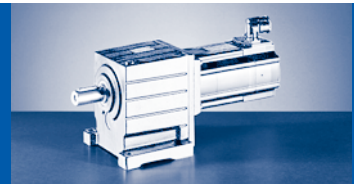

$M_{2GN} \leq 2933 \text{ Nm}$

19SC17	19SC23	19SC35	19SC42	21XC17	21XC25	21XC35	21XC42	GST11-2A			
...F10	...500	...F10	...500	...F10	...500	...F10	...500	$M_1$	$J_G$	$M_{2GN}$	$i$
36.30	16.30	36.00	12.00	61.40	24.60	55.00	17.00	$n_1$			
1700	2340	3510	4150	1710	2490	3520	4160	$l_{M400}$			
13.9	8.2	28.7	14.0	22.5	13.5	42.5	19.8	$P_N$			
6.40	4.00	13.20	5.20	11.00	6.40	20.30	7.40	$J_M$			
72.12	72.12	72.04	72.12	180.04	180.04	180.04	180.04	$M_2$			
								c	28.70	1607	14.286
								$n_{2 \text{ Eck}}$			
								$n_{2 \text{ th}}$			
483		484		834		750		$M_2$	28.70	2579	14.286
4.9		3.9		2.9		2.6		c			
119		246		120		246		$n_{2 \text{ Eck}}$			
119		153		120		139		$n_{2 \text{ th}}$			
520		520		899		807		$M_2$	23.00	2695	15.400
5.0		4.3		2.9		2.8		c			
110		228		111		229		$n_{2 \text{ Eck}}$			
110		159		111		131		$n_{2 \text{ th}}$			
594		593		1025		919		$M_2$	22.50	2758	17.500
4.5		3.9		2.7		2.5		c			
97		201		98		201		$n_{2 \text{ Eck}}$			
97		140		98		115		$n_{2 \text{ th}}$			
								$M_2$	14.30	1570	20.289
								c			
								$n_{2 \text{ Eck}}$			
								$n_{2 \text{ th}}$			
694		692		1193	462	1070		$M_2$	14.30	2756	20.289
3.9		3.3		2.3	5.5	2.2		c			
84		173		84	123	174		$n_{2 \text{ Eck}}$			
84		121		84	99	99		$n_{2 \text{ th}}$			
								$M_2$	14.10	1784	23.056
								c			
								$n_{2 \text{ Eck}}$			
								$n_{2 \text{ th}}$			
790		788		1358	527	1217		$M_2$	14.10	2913	23.056
3.6		3.1		2.1	5.1	2.0		c			
74		152		74	108	153		$n_{2 \text{ Eck}}$			
74		106		74	87	87		$n_{2 \text{ th}}$			
								$M_2$	10.60	1616	24.933
								c			
								$n_{2 \text{ Eck}}$			
								$n_{2 \text{ th}}$			
859		855		1472	574	1320	392	$M_2$	10.60	2777	24.933
3.2		2.7		1.9	4.5	1.8	5.5	c			
68		141		69	100	141	167	$n_{2 \text{ Eck}}$			
68		98		69	81	81	81	$n_{2 \text{ th}}$			
								$M_2$	10.40	1836	28.333
								c			
								$n_{2 \text{ Eck}}$			
								$n_{2 \text{ th}}$			
978		974		1675	654	1502	448	$M_2$	10.40	2933	28.333
2.9		2.5		1.7	4.2	1.7	5.1	c			
60		124		60	88	124	147	$n_{2 \text{ Eck}}$			
60		86		60	71	71	71	$n_{2 \text{ th}}$			
								$M_2$	7.04	1430	32.267
								c			
								$n_{2 \text{ Eck}}$			
								$n_{2 \text{ th}}$			

$M \dots$  [Nm]  
 $n \dots$  [r/min]  
 $J \dots$  [kgcm<sup>2</sup>]

$P \dots$  [kW]  
 $I \dots$  [A]  
 $i [-]$   
 $c [-]$

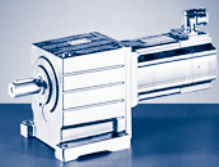

# GST [Nm]

## GST□□-□A (MCA)

$M_{2GN} \leq 2933 \text{ Nm}$

GST11-2A				14LC16	14LC20	14LC35	14LC41	17NC17	17NC23	17NC35	17NC41
i	$M_{2GN}$	$J_G$	$M_1$	...F10	...S00	...F10	...S00	...F10	...S00	...F10	...S00
			$n_1$	12.00	6.70	10.80	5.40	21.50	10.80	19.00	9.50
			$I_{M400}$	1635	2000	3455	4100	1680	2300	3480	4110
			$P_N$	4.8	3.3	9.1	5.8	8.5	5.5	15.8	10.2
			$J_M$	2.10	1.40	3.90	2.30	3.80	2.60	6.90	4.10
			$M_2$	19.32	19.24	19.24	19.24	36.04	36.04	36.04	36.04
			c					663	325	586	286
32.267	1674	7.04	$n_{2 \text{ Eck}}$					2.5	4.9	2.4	4.6
			$n_{2 \text{ th}}$					52	71	108	127
			$n_{2 \text{ th}}$					52	71	96	96
32.267	2818	7.04	$M_2$								
			c								
			$n_{2 \text{ Eck}}$								
			$n_{2 \text{ th}}$								
36.667	1624	6.93	$M_2$	415		374					
			c	3.8		3.6					
			$n_{2 \text{ Eck}}$	45		94					
			$n_{2 \text{ th}}$	45		94					
36.667	1902	6.93	$M_2$					753	369	666	326
			c					2.5	4.9	2.4	4.6
			$n_{2 \text{ Eck}}$					46	63	95	112
			$n_{2 \text{ th}}$					46	63	85	85
36.667	2933	6.93	$M_2$								
			c								
			$n_{2 \text{ Eck}}$								
			$n_{2 \text{ th}}$								
39.160	1452	5.15	$M_2$	446	242	402	195				
			c	3.2	5.7	3.1	5.8				
			$n_{2 \text{ Eck}}$	42	51	88	105				
			$n_{2 \text{ th}}$	42	51	88	92				
39.160	1701	5.15	$M_2$					808	397	714	350
			c					2.1	4.1	2.0	3.8
			$n_{2 \text{ Eck}}$					43	59	89	105
			$n_{2 \text{ th}}$					43	59	79	79
39.160	2826	5.15	$M_2$								
			c								
			$n_{2 \text{ Eck}}$								
			$n_{2 \text{ th}}$								
44.500	1650	5.08	$M_2$	506	275	455					
			c	3.2	5.7	3.4					
			$n_{2 \text{ Eck}}$	37	45	78					
			$n_{2 \text{ th}}$	37	45	78					
44.500	1933	5.08	$M_2$					918	451	810	396
			c					2.1	4.2	2.2	4.2
			$n_{2 \text{ Eck}}$					38	52	78	92
			$n_{2 \text{ th}}$					38	52	70	70
44.500	2933	5.08	$M_2$								
			c								
			$n_{2 \text{ Eck}}$								
			$n_{2 \text{ th}}$								
49.500	1476	3.52	$M_2$	567	310	510	248				
			c	2.6	4.6	2.7	5.1				
			$n_{2 \text{ Eck}}$	33	40	70	83				
			$n_{2 \text{ th}}$	33	40	70	73				
49.500	1728	3.52	$M_2$					1025	506	905	445
			c					1.7	3.3	1.8	3.4
			$n_{2 \text{ Eck}}$					34	47	70	83
			$n_{2 \text{ th}}$					34	46	63	63

$M \dots$  [Nm]  
 $n \dots$  [r/min]  
 $J \dots$  [kgcm<sup>2</sup>]

$P \dots$  [kW]  
 $I \dots$  [A]  
 $i$  [-]  
 $c$  [-]

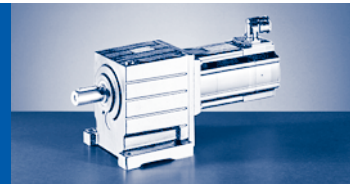

$M_{2GN} \leq 2933 \text{ Nm}$

195C17	195C23	195C35	195C42	21XC17	21XC25	21XC35	21XC42	GST11-2A			
...F10	...500	...F10	...500	...F10	...500	...F10	...500	$M_1$	$J_G$	$M_{2GN}$	$i$
36.30	16.30	36.00	12.00	61.40	24.60	55.00	17.00	$n_1$			
1700	2340	3510	4150	1710	2490	3520	4160	$I_{M400}$			
13.9	8.2	28.7	14.0	22.5	13.5	42.5	19.8	$P_N$			
6.40	4.00	13.20	5.20	11.00	6.40	20.30	7.40	$J_M$			
72.12	72.12	72.04	72.12	180.04	180.04	180.04	180.04	$M_2$ c	7.04	1674	32.267
								$n_{2 \text{ Eck}}$ $n_{2 \text{ th}}$			
1119	487	1114						$M_2$ c	7.04	2818	32.267
2.5	5.4	2.1						$n_{2 \text{ Eck}}$ $n_{2 \text{ th}}$			
53	73	109						$M_2$ c	6.93	1624	36.667
53	73	76						$n_{2 \text{ Eck}}$ $n_{2 \text{ th}}$			
								$M_2$ c	6.93	1902	36.667
								$n_{2 \text{ Eck}}$ $n_{2 \text{ th}}$			
1274	556	1268	407					$M_2$ c	6.93	2933	36.667
2.3	5.0	2.0	5.6					$n_{2 \text{ Eck}}$ $n_{2 \text{ th}}$			
46	64	96	113					$M_2$ c	5.15	1452	39.160
46	64	67	67					$n_{2 \text{ Eck}}$ $n_{2 \text{ th}}$			
								$M_2$ c	5.15	1701	39.160
								$n_{2 \text{ Eck}}$ $n_{2 \text{ th}}$			
1364	597	1357	437					$M_2$ c	5.15	2826	39.160
2.1	4.5	1.8	5.0					$n_{2 \text{ Eck}}$ $n_{2 \text{ th}}$			
43	60	90	106					$M_2$ c	5.08	1650	44.500
43	60	63	63					$n_{2 \text{ Eck}}$ $n_{2 \text{ th}}$			
								$M_2$ c	5.08	1933	44.500
								$n_{2 \text{ Eck}}$ $n_{2 \text{ th}}$			
1553	681	1542	496					$M_2$ c	5.08	2933	44.500
1.9	4.2	1.8	5.1					$n_{2 \text{ Eck}}$ $n_{2 \text{ th}}$			
38	53	79	93					$M_2$ c	3.52	1476	49.500
38	53	55	55					$n_{2 \text{ Eck}}$ $n_{2 \text{ th}}$			
								$M_2$ c	3.52	1728	49.500
								$n_{2 \text{ Eck}}$ $n_{2 \text{ th}}$			

$M \dots$  [Nm]  
 $n \dots$  [r/min]  
 $J \dots$  [kgcm<sup>2</sup>]

$P \dots$  [kW]  
 $I \dots$  [A]  
 $i$  [-]  
 $c$  [-]

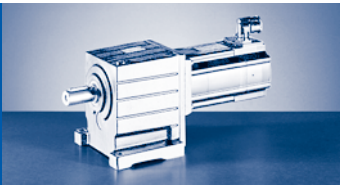

# GST [Nm]

## GST□□-□A (MCA)

$M_{2GN} \leq 2933 \text{ Nm}$

GST11-2A				14LC16	14LC20	14LC35	14LC41	17NC17	17NC23	17NC35	17NC41
				...F10	...S00	...F10	...S00	...F10	...S00	...F10	...S00
i	$M_{2GN}$	$J_G$	$M_1$	12.00	6.70	10.80	5.40	21.50	10.80	19.00	9.50
			$n_1$	1635	2000	3455	4100	1680	2300	3480	4110
			$I_{M400}$	4.8	3.3	9.1	5.8	8.5	5.5	15.8	10.2
			$P_N$	2.10	1.40	3.90	2.30	3.80	2.60	6.90	4.10
			$J_M$	19.32	19.24	19.24	19.24	36.04	36.04	36.04	36.04
56.250	1677	3.44	$M_2$	644	352	579	282				
			c	2.6	4.6	2.7	5.1				
			$n_{2Eck}$	29	36	61	73				
			$n_{2th}$	29	36	61	64				
56.250	1964	3.44	$M_2$					1165	575	1028	506
			c					1.7	3.3	1.8	3.4
			$n_{2Eck}$					30	41	62	73
			$n_{2th}$					30	41	55	55

M ... [Nm]  
 n ... [r/min]  
 J ... [kgcm<sup>2</sup>]

P ... [kW]  
 I ... [A]  
 i [-]  
 c [-]

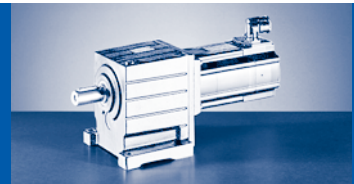

$M_{2GN} \leq 2933 \text{ Nm}$

19SC17	19SC23	19SC35	19SC42	21XC17	21XC25	21XC35	21XC42	GST11-2A			
...F10	...500	...F10	...500	...F10	...500	...F10	...500	$M_1$	$J_G$	$M_{2GN}$	$i$
36.30	16.30	36.00	12.00	61.40	24.60	55.00	17.00	$n_1$			
1700	2340	3510	4150	1710	2490	3520	4160	$I_{M400}$			
13.9	8.2	28.7	14.0	22.5	13.5	42.5	19.8	$P_N$			
6.40	4.00	13.20	5.20	11.00	6.40	20.30	7.40	$J_M$			
72.12	72.12	72.04	72.12	180.04	180.04	180.04	180.04	$M_2$ c	3.44	1677	56.250
								$n_{2 \text{ Eck}}$ $n_{2 \text{ th}}$			
								$M_2$ c	3.44	1964	56.250
								$n_{2 \text{ Eck}}$ $n_{2 \text{ th}}$			

M ... [Nm]  
n ... [r/min]  
J ... [kgcm<sup>2</sup>]

P ... [kW]  
I ... [A]  
i [-]  
c [-]

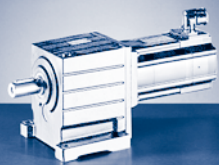

# GST [Nm]

## GST□□-□A (MCA)

$M_{2GN} \leq 2848 \text{ Nm}$

GST11-3A				10IC40	13IC34	13IC41	14LC16	14LC20	14LC35	14LC41
				...S00	...F10	...S00	...F10	...S00	...F10	...S00
i	$M_{2GN}$	$J_G$	$M_1$	2.00	6.30	4.00	12.00	6.70	10.80	5.40
			$n_1$	3950	3410	4050	1635	2000	3455	4100
			$I_{M400}$	2.4	6.0	4.4	4.8	3.3	9.1	5.8
			$P_N$	0.80	2.20	1.70	2.10	1.40	3.90	2.30
			$J_M$	2.44	8.34	8.34	19.32	19.24	19.24	19.24
40.816	1641	6.36	$M_2$		233					
			c		5.8					
			$n_{2 \text{ Eck}}$		84					
			$n_{2 \text{ th}}$		84					
40.816	2444	6.36	$M_2$				447		404	
			c				5.2		5.0	
			$n_{2 \text{ Eck}}$				40		85	
			$n_{2 \text{ th}}$				40		85	
40.816	2550	6.36	$M_2$							
			c							
			$n_{2 \text{ Eck}}$							
			$n_{2 \text{ th}}$							
44.000	2410	5.66	$M_2$				485		435	
			c				4.8		5.1	
			$n_{2 \text{ Eck}}$				37		79	
			$n_{2 \text{ th}}$				37		79	
50.000	2725	5.60	$M_2$				551		494	
			c				4.8		5.0	
			$n_{2 \text{ Eck}}$				33		69	
			$n_{2 \text{ th}}$				33		69	
57.968	2577	4.77	$M_2$				645		579	
			c				3.9		4.1	
			$n_{2 \text{ Eck}}$				28		60	
			$n_{2 \text{ th}}$				28		60	
61.250	2725	4.08	$M_2$				681		612	
			c				3.9		4.1	
			$n_{2 \text{ Eck}}$				27		56	
			$n_{2 \text{ th}}$				27		56	
71.011	2637	3.52	$M_2$				795	432	714	
			c				3.2	5.8	3.4	
			$n_{2 \text{ Eck}}$				23	28	49	
			$n_{2 \text{ th}}$				23	28	49	
80.694	2787	3.50	$M_2$				906	493	814	
			c				3.0	5.4	3.2	
			$n_{2 \text{ Eck}}$				20	25	43	
			$n_{2 \text{ th}}$				20	25	43	
87.267	2657	3.22	$M_2$				983	537	884	430
			c				2.7	4.8	2.8	5.3
			$n_{2 \text{ Eck}}$				19	23	40	47
			$n_{2 \text{ th}}$				19	23	40	41
99.167	2810	3.20	$M_2$				1120	612	1006	491
			c				2.5	4.4	2.6	5.0
			$n_{2 \text{ Eck}}$				17	20	35	41
			$n_{2 \text{ th}}$				16	20	35	36
112.933	2695	2.93	$M_2$				1280	702	1151	563
			c				2.1	3.7	2.2	4.2
			$n_{2 \text{ Eck}}$				15	18	31	36
			$n_{2 \text{ th}}$				14	18	31	32
129.074	2810	1.94	$M_2$		757	472	1466	806	1318	647
			c		3.5	5.2	1.9	3.4	2.0	3.8
			$n_{2 \text{ Eck}}$		26	31	13	16	27	32
			$n_{2 \text{ th}}$		26	31	13	15	27	28

$M \dots$  [Nm]  
 $n \dots$  [r/min]  
 $J \dots$  [kgcm<sup>2</sup>]

$P \dots$  [kW]  
 $I \dots$  [A]  
 $i$  [-]  
 $c$  [-]

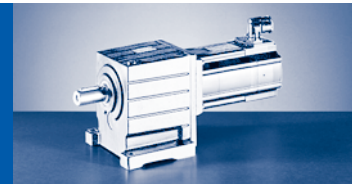

$M_{2GN} \leq 2848 \text{ Nm}$

17NC17	17NC23	17NC35	17NC41	19SC17	19SC23	19SC35	19SC42	GST11-3A			
...F10	...500	...F10	...500	...F10	...500	...F10	...500	$M_1$	$J_G$	$M_{2GN}$	$i$
21.50	10.80	19.00	9.50	36.30	16.30	36.00	12.00	$n_1$			
1680	2300	3480	4110	1700	2340	3510	4150	$l_{M400}$			
8.5	5.5	15.8	10.2	13.9	8.2	28.7	14.0	$P_N$			
3.80	2.60	6.90	4.10	6.40	4.00	13.20	5.20	$J_M$			
36.04	36.04	36.04	36.04	72.12	72.12	72.04	72.12	$M_2$			
								c	6.36	1641	40.816
								$n_{2 \text{ Eck}}$			
								$n_{2 \text{ th}}$			
								$M_2$	6.36	2444	40.816
								c			
								$n_{2 \text{ Eck}}$			
								$n_{2 \text{ th}}$			
821	399	726	353	1404	616	1396	451	$M_2$	6.36	2550	40.816
3.0	6.0	3.0	5.6	1.8	3.9	1.6	4.4	c			
41	56	85	101	42	57	86	102	$n_{2 \text{ Eck}}$			
41	56	76	76	42	57	60	60	$n_{2 \text{ th}}$			
888	434	783	381	1517	667	1506	487	$M_2$	5.66	2410	44.000
2.7	5.3	2.9	5.4	1.6	3.5	1.5	4.3	c			
38	52	79	93	39	53	80	94	$n_{2 \text{ Eck}}$			
38	52	71	71	39	53	56	56	$n_{2 \text{ th}}$			
1010	493	890	433	1724	759	1711	554	$M_2$	5.60	2725	50.000
2.7	5.3	2.9	5.4	1.6	3.5	1.5	4.3	c			
34	46	70	82	34	47	70	83	$n_{2 \text{ Eck}}$			
34	46	62	62	34	47	49	49	$n_{2 \text{ th}}$			
1177	578	1038	508	2005	885	1990	648	$M_2$	4.77	2577	57.968
2.2	4.3	2.3	4.4	1.3	2.9	1.2	3.5	c			
29	40	60	71	29	40	61	72	$n_{2 \text{ Eck}}$			
29	40	54	54	29	40	42	42	$n_{2 \text{ th}}$			
1243	610	1097	536	2119	936	2102	684	$M_2$	4.08	2725	61.250
2.2	4.3	2.3	4.4	1.3	2.9	1.2	3.5	c			
27	38	57	67	28	38	57	68	$n_{2 \text{ Eck}}$			
27	38	51	51	28	38	40	40	$n_{2 \text{ th}}$			
1447	713	1277	627	2462	1090	2442	798	$M_2$	3.52	2637	71.011
1.8	3.6	2.0	3.7	1.1	2.4	1.0	2.9	c			
24	32	49	58	24	33	49	58	$n_{2 \text{ Eck}}$			
24	32	44	44	24	33	34	34	$n_{2 \text{ th}}$			
1646	812	1453	714		1241		909	$M_2$	3.50	2787	80.694
1.7	3.4	1.8	3.4		2.2		2.7	c			
21	29	43	51		29		51	$n_{2 \text{ Eck}}$			
21	29	39	39		29		30	$n_{2 \text{ th}}$			
1784	882	1575	776		1346		986	$M_2$	3.22	2657	87.267
1.5	3.0	1.6	3.0		2.0		2.4	c			
19	26	40	47		27		48	$n_{2 \text{ Eck}}$			
19	26	36	36		27		28	$n_{2 \text{ th}}$			
2029	1005	1792	883		1532		1123	$M_2$	3.20	2810	99.167
1.4	2.8	1.5	2.8		1.8		2.2	c			
17	23	35	42		24		42	$n_{2 \text{ Eck}}$			
17	23	31	31		24		25	$n_{2 \text{ th}}$			
2317	1150	2045	1011		1749		1283	$M_2$	2.93	2695	112.933
1.2	2.3	1.3	2.4		1.5		1.9	c			
15	20	31	36		21		37	$n_{2 \text{ Eck}}$			
15	20	28	28		21		22	$n_{2 \text{ th}}$			
2650	1317	2340	1158					$M_2$	1.94	2810	129.074
1.1	2.1	1.1	2.2					c			
13	18	27	32					$n_{2 \text{ Eck}}$			
13	18	24	24					$n_{2 \text{ th}}$			

M ... [Nm]  
n ... [r/min]  
J ... [kgcm<sup>2</sup>]

P ... [kW]  
I ... [A]  
i [-]  
c [-]

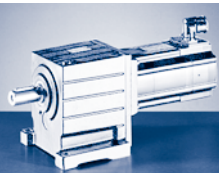

# GST [Nm]

## GST□□-□A (MCA)

$M_{2GN} \leq 2848 \text{ Nm}$

GST11-3A				10IC40	13IC34	13IC41	14LC16	14LC20	14LC35	14LC41
				...S00	...F10	...S00	...F10	...S00	...F10	...S00
i	$M_{2GN}$	$J_G$	$M_1$	2.00	6.30	4.00	12.00	6.70	10.80	5.40
			$n_1$	3950	3410	4050	1635	2000	3455	4100
			$I_{M400}$	2.4	6.0	4.4	4.8	3.3	9.1	5.8
			$P_N$	0.80	2.20	1.70	2.10	1.40	3.90	2.30
			$J_M$	2.44	8.34	8.34	19.32	19.24	19.24	19.24
146.993	2695	1.77	$M_2$		867	542	1675	923	1506	741
			c		2.9	4.3	1.6	2.9	1.7	3.2
			$n_{2 \text{ Eck}}$		23	28	11	14	24	28
			$n_{2 \text{ th}}$		23	28	11	14	24	24
158.194	2810	1.40	$M_2$		934	584	1804	994	1622	798
			c		2.8	4.2	1.6	2.8	1.6	3.1
			$n_{2 \text{ Eck}}$		22	26	10	13	22	26
			$n_{2 \text{ th}}$		22	26	10	13	22	23
180.156	2695	1.29	$M_2$		1069	670	2059	1137	1852	914
			c		2.4	3.5	1.3	2.3	1.4	2.6
			$n_{2 \text{ Eck}}$		19	23	9	11	19	23
			$n_{2 \text{ th}}$		19	22	9	11	19	20
207.778	2810	0.88	$M_2$		1236	776	2378	1315	2139	1057
			c		2.2	3.2	1.2	2.1	1.3	2.4
			$n_{2 \text{ Eck}}$		16	20	8	10	17	20
			$n_{2 \text{ th}}$		16	19	8	10	17	17
236.622	2695	0.82	$M_2$	431	1413	888		1503	2441	1208
			c	5.4	1.8	2.7		1.8	1.1	2.0
			$n_{2 \text{ Eck}}$	17	14	17		9	15	17
			$n_{2 \text{ th}}$	17	14	17		8	15	15
252.167	2810	0.63	$M_2$	460	1506	947		1602	2602	1288
			c	5.3	1.8	2.6		1.7	1.0	2.0
			$n_{2 \text{ Eck}}$	16	14	16		8	14	16
			$n_{2 \text{ th}}$	16	14	16		8	14	14
268.889	2848	0.82	$M_2$	492	1607	1012		1710		1375
			c	5.1	1.7	2.5		1.7		1.9
			$n_{2 \text{ Eck}}$	15	13	15		7		15
			$n_{2 \text{ th}}$	15	13	15		7		13
326.333	2848	0.59	$M_2$	603	1957	1234		2082		1675
			c	4.2	1.4	2.1		1.4		1.5
			$n_{2 \text{ Eck}}$	12	11	12		6		13
			$n_{2 \text{ th}}$	12	10	12		6		11
363.000	2695	0.76	$M_2$	675	2181	1377				
			c	3.5	1.2	1.8				
			$n_{2 \text{ Eck}}$	11	9	11				
			$n_{2 \text{ th}}$	11	9	11				
412.500	2848	0.55	$M_2$	769	2481	1566				
			c	3.3	1.1	1.6				
			$n_{2 \text{ Eck}}$	10	8	10				
			$n_{2 \text{ th}}$	10	8	10				

M ... [Nm]  
 n ... [r/min]  
 J ... [kgcm<sup>2</sup>]

P ... [kW]  
 I ... [A]  
 i [-]  
 c [-]

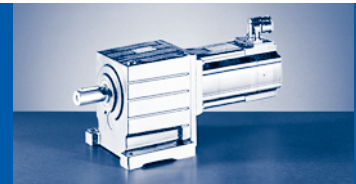

$M_{2GN} \leq 2848 \text{ Nm}$

17NC17	17NC23	17NC35	17NC41	19SC17	19SC23	19SC35	19SC42	GST11-3A			
...F10	...500	...F10	...500	...F10	...500	...F10	...500	$M_1$	$J_G$	$M_{2GN}$	$i$
21.50	10.80	19.00	9.50	36.30	16.30	36.00	12.00	$n_1$			
1680	2300	3480	4110	1700	2340	3510	4150	$l_{M400}$			
8.5	5.5	15.8	10.2	13.9	8.2	28.7	14.0	$P_N$			
3.80	2.60	6.90	4.10	6.40	4.00	13.20	5.20	$J_M$			
36.04	36.04	36.04	36.04	72.12	72.12	72.04	72.12	$M_2$			
	1505		1323					$c$	1.77	2695	146.993
	1.8		1.8					$n_{2 \text{ Eck}}$			
	16		28					$n_{2 \text{ th}}$			
	16		21					$M_2$			
	1620		1425					$c$	1.40	2810	158.194
	1.7		1.8					$n_{2 \text{ Eck}}$			
	15		26					$n_{2 \text{ th}}$			
	15		20					$M_2$			
	1851		1627					$c$	1.29	2695	180.156
	1.5		1.5					$n_{2 \text{ Eck}}$			
	13		23					$n_{2 \text{ th}}$			
	13		17					$M_2$			
								$c$	0.88	2810	207.778
								$n_{2 \text{ Eck}}$			
								$n_{2 \text{ th}}$			
								$M_2$			
								$c$	0.82	2695	236.622
								$n_{2 \text{ Eck}}$			
								$n_{2 \text{ th}}$			
								$M_2$			
								$c$	0.63	2810	252.167
								$n_{2 \text{ Eck}}$			
								$n_{2 \text{ th}}$			
								$M_2$			
								$c$	0.82	2848	268.889
								$n_{2 \text{ Eck}}$			
								$n_{2 \text{ th}}$			
								$M_2$			
								$c$	0.59	2848	326.333
								$n_{2 \text{ Eck}}$			
								$n_{2 \text{ th}}$			
								$M_2$			
								$c$	0.76	2695	363.000
								$n_{2 \text{ Eck}}$			
								$n_{2 \text{ th}}$			
								$M_2$			
								$c$	0.55	2848	412.500
								$n_{2 \text{ Eck}}$			
								$n_{2 \text{ th}}$			

M ... [Nm]  
n ... [r/min]  
J ... [kgcm<sup>2</sup>]

P ... [kW]  
I ... [A]  
i [-]  
c [-]

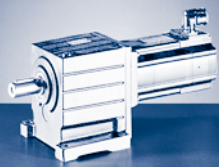

# GST [Nm]

## GST□□-□A (MCA)

$M_{2GN} \leq 5786 \text{ Nm}$

GST14-2A				19SC17	19SC23	19SC35	21XC17	21XC25	21XC35
i	$M_{2GN}$	$J_G$	$M_1$	...F10	...500	...F10	...F10	...500	...F10
			$n_1$	36.30	16.30	36.00	61.40	24.60	55.00
			$I_{M400}$	1700	2340	3510	1710	2490	3520
			$P_N$	13.9	8.2	28.7	22.5	13.5	42.5
			$J_M$	6.40	4.00	13.20	11.00	6.40	20.30
			$M_2$	72.12	72.12	72.04	180.04	180.04	180.04
8.027	3168	100.00	c						408
			$n_{2 \text{ Eck}}$						5.6
			$n_{2 \text{ th}}$						439
			$M_2$						251
8.800	3737	139.00	c						445
			$n_{2 \text{ Eck}}$						6.0
			$n_{2 \text{ th}}$						400
			$M_2$						195
9.841	3333	75.10	c				559		505
			$n_{2 \text{ Eck}}$				5.4		4.8
			$n_{2 \text{ th}}$				174		358
			$M_2$				174		205
11.000	3940	119.00	c				623		562
			$n_{2 \text{ Eck}}$				5.8		5.1
			$n_{2 \text{ th}}$				156		320
			$M_2$				155		154
12.362	4176	89.00	c				703		634
			$n_{2 \text{ Eck}}$				5.4		4.8
			$n_{2 \text{ th}}$				138		285
			$M_2$				138		158
14.048	4270	86.60	c				803		724
			$n_{2 \text{ Eck}}$				4.9		4.3
			$n_{2 \text{ th}}$				122		251
			$M_2$				122		136
15.156	4466	67.60	c				866		778
			$n_{2 \text{ Eck}}$				5.0		4.7
			$n_{2 \text{ th}}$				113		232
			$M_2$				113		133
17.222	4565	66.00	c				989		888
			$n_{2 \text{ Eck}}$				4.5		4.3
			$n_{2 \text{ th}}$				99		204
			$M_2$				99		117
20.044	3958	45.80	c	672		672			
			$n_{2 \text{ Eck}}$	5.6		4.8			
			$n_{2 \text{ th}}$	85		175			
			$M_2$	85		122			
20.044	4902	45.80	c				1156		1037
			$n_{2 \text{ Eck}}$				4.1		3.9
			$n_{2 \text{ th}}$				85		176
			$M_2$				85		100
22.778	4498	44.90	c	764		764			
			$n_{2 \text{ Eck}}$	5.6		4.8			
			$n_{2 \text{ th}}$	75		154			
			$M_2$	75		108			
22.778	5010	44.90	c				1319		1184
			$n_{2 \text{ Eck}}$				3.7		3.5
			$n_{2 \text{ th}}$				75		155
			$M_2$				75		88
24.567	4286	33.20	c	830		829			
			$n_{2 \text{ Eck}}$	5.0		4.3			
			$n_{2 \text{ th}}$	69		143			
			$M_2$	69		100			

M ... [Nm]  
n ... [r/min]  
J ... [kgcm<sup>2</sup>]

P ... [kW]  
I ... [A]  
i [-]  
c [-]

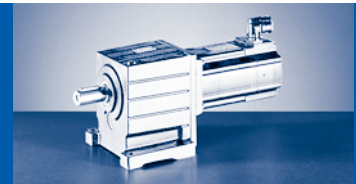

$M_{2GN} \leq 5786 \text{ Nm}$

GST14-2A				19SC17	19SC23	19SC35	21XC17	21XC25	21XC35
				...F10	...500	...F10	...F10	...500	...F10
i	$M_{2GN}$	$J_G$	$M_1$						
			$n_1$	1700	2340	3510	1710	2490	3520
			$I_{M400}$	13.9	8.2	28.7	22.5	13.5	42.5
			$P_N$	6.40	4.00	13.20	11.00	6.40	20.30
			$J_M$	72.12	72.12	72.04	180.04	180.04	180.04
24.567	5236	33.20	$M_2$				1425		1278
			c				3.6		3.4
			$n_{2 \text{ Eck}}$				70		143
			$n_{2 \text{ th}}$				70		82
27.917	4871	32.60	$M_2$	943		942			
			c	5.0		4.3			
			$n_{2 \text{ Eck}}$	61		126			
			$n_{2 \text{ th}}$	61		88			
27.917	5355	32.60	$M_2$				1625		1458
			c				3.2		3.1
			$n_{2 \text{ Eck}}$				61		126
			$n_{2 \text{ th}}$				61		72
32.267	4423	21.50	$M_2$	1103		1100			
			c	3.9		3.4			
			$n_{2 \text{ Eck}}$	53		109			
			$n_{2 \text{ th}}$	53		76			
32.267	5436	21.50	$M_2$				1886		1692
			c				2.8		2.7
			$n_{2 \text{ Eck}}$				53		109
			$n_{2 \text{ th}}$				53		62
36.667	5026	21.20	$M_2$	1253		1250			
			c	3.9		3.4			
			$n_{2 \text{ Eck}}$	46		96			
			$n_{2 \text{ th}}$	46		67			
36.667	5768	21.20	$M_2$				2147		1926
			c				2.6		2.5
			$n_{2 \text{ Eck}}$				47		96
			$n_{2 \text{ th}}$				47		55
39.160	4493	15.70	$M_2$	1347		1342			
			c	3.3		2.8			
			$n_{2 \text{ Eck}}$	43		90			
			$n_{2 \text{ th}}$	43		63			
39.160	5452	15.70	$M_2$				2301	890	2063
			c				2.3	5.6	2.2
			$n_{2 \text{ Eck}}$				44	64	90
			$n_{2 \text{ th}}$				44	51	51
44.500	5106	15.50	$M_2$	1531		1520			
			c	3.3		3.1			
			$n_{2 \text{ Eck}}$	38		79			
			$n_{2 \text{ th}}$	38		55			
44.500	5786	15.50	$M_2$				2619	1013	2343
			c				2.2	5.5	2.3
			$n_{2 \text{ Eck}}$				38	56	79
			$n_{2 \text{ th}}$				38	45	45
49.500	4348	10.60	$M_2$	1717	746	1704			
			c	2.5	5.6	2.4			
			$n_{2 \text{ Eck}}$	34	47	71			
			$n_{2 \text{ th}}$	34	47	49			
56.250	4940	10.50	$M_2$	1951	848	1937			
			c	2.5	5.6	2.4			
			$n_{2 \text{ Eck}}$	30	42	62			
			$n_{2 \text{ th}}$	30	42	44			

M ... [Nm]  
n ... [r/min]  
J ... [kgcm<sup>2</sup>]

P ... [kW]  
I ... [A]  
i [-]  
c [-]

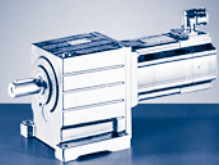

# GST [Nm]

## GST□□-□A (MCA)

$M_{2GN} \leq 5920 \text{ Nm}$

GST14-3A				14LC16	14LC20	14LC35	14LC41	17NC17	17NC23	17NC35	17NC41
i	$M_{2GN}$	$J_G$	$M_1$	...F10	...S00	...F10	...S00	...F10	...S00	...F10	...S00
			$n_1$	12.00	6.70	10.80	5.40	21.50	10.80	19.00	9.50
			$I_{M400}$	1635	2000	3455	4100	1680	2300	3480	4110
			$P_N$	4.8	3.3	9.1	5.8	8.5	5.5	15.8	10.2
			$J_M$	2.10	1.40	3.90	2.30	3.80	2.60	6.90	4.10
			$M_2$	19.32	19.24	19.24	19.24	36.04	36.04	36.04	36.04
			c					791		700	
40.185	4099	24.40	$n_{2Eck}$					5.0		4.8	
			$n_{2th}$					42		87	
			$M_2$					42		77	
			c								
40.185	4476	24.40	$n_{2Eck}$								
			$n_{2th}$								
			$M_2$								
			c					844		743	
42.580	3804	18.30	$n_{2Eck}$					4.4		4.7	
			$n_{2th}$					40		82	
			$M_2$					39		73	
			c								
42.580	4262	18.30	$n_{2Eck}$								
			$n_{2th}$								
			$M_2$								
			c					959		845	
48.386	4323	18.10	$n_{2Eck}$					4.4		4.7	
			$n_{2th}$					35		72	
			$M_2$					35		64	
			c								
48.386	4843	18.10	$n_{2Eck}$								
			$n_{2th}$								
			$M_2$								
			c					1053		928	
53.148	4779	20.50	$n_{2Eck}$					4.4		4.7	
			$n_{2th}$					32		66	
			$M_2$					32		59	
			c								
59.321	4546	13.20	$n_{2Eck}$					1184		1043	
			$n_{2th}$					3.7		4.0	
			$M_2$					28		59	
			c					28		52	
			$n_{2Eck}$								
			$n_{2th}$								
			$M_2$								
			c					1382		1218	
69.042	4917	11.50	$n_{2Eck}$					3.5		3.7	
			$n_{2th}$					24		50	
			$M_2$					24		45	
			c								
78.457	5587	11.40	$n_{2Eck}$					1570		1384	
			$n_{2th}$					3.5		3.7	
			$M_2$					21		44	
			c					21		40	
			$n_{2Eck}$								
			$n_{2th}$								
			$M_2$	1034		928					
			c	4.5		4.7					
93.541	4793	6.57	$n_{2Eck}$								
			$n_{2th}$								
			$M_2$					1884	918	1661	806
			c					2.9	5.7	3.1	5.9
93.541	5524	6.57	$n_{2Eck}$					18	25	37	44
			$n_{2th}$					18	25	33	33

$M \dots$  [Nm]  
 $n \dots$  [r/min]  
 $J \dots$  [kgcm<sup>2</sup>]

$P \dots$  [kW]  
 $I \dots$  [A]  
 $i$  [-]  
 $c$  [-]

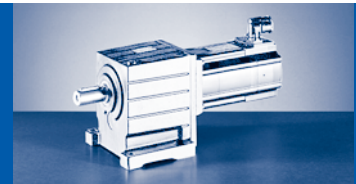

$M_{2GN} \leq 5920 \text{ Nm}$

19SC17	19SC23	19SC35	19SC42	21XC17	21XC25	21XC35	21XC42	GST14-3A			
...F10	...500	...F10	...500	...F10	...500	...F10	...500	$M_1$	$J_G$	$M_{2GN}$	i
36.30	16.30	36.00	12.00	61.40	24.60	55.00	17.00	$n_1$			
1700	2340	3510	4150	1710	2490	3520	4160	$I_{M400}$			
13.9	8.2	28.7	14.0	22.5	13.5	42.5	19.8	$P_N$			
6.40	4.00	13.20	5.20	11.00	6.40	20.30	7.40	$J_M$			
72.12	72.12	72.04	72.12	180.04	180.04	180.04	180.04	$M_2$ c			
								$n_{2 \text{ Eck}}$	24.40	4099	40.185
								$n_{2 \text{ th}}$			
1362		1357		2336	910	2094	622	$M_2$ c			
3.2		2.8		1.9	4.6	1.8	5.5	$n_{2 \text{ Eck}}$	24.40	4476	40.185
42		87		43	62	88	104	$n_{2 \text{ th}}$			
42		61		43	50	50	50				
								$M_2$ c			
								$n_{2 \text{ Eck}}$	18.30	3804	42.580
								$n_{2 \text{ th}}$			
1448		1438		2480	967	2219	659	$M_2$ c			
2.9		2.8		1.7	4.3	1.8	5.5	$n_{2 \text{ Eck}}$	18.30	4262	42.580
40		82		40	59	83	98	$n_{2 \text{ th}}$			
40		58		40	47	47	47				
								$M_2$ c			
								$n_{2 \text{ Eck}}$	18.10	4323	48.386
								$n_{2 \text{ th}}$			
1645		1634		2818	1099	2522	749	$M_2$ c			
2.9		2.8		1.7	4.3	1.8	5.5	$n_{2 \text{ Eck}}$	18.10	4843	48.386
35		73		35	52	73	86	$n_{2 \text{ th}}$			
35		51		35	42	42	42				
1813	787	1800		3101	1213	2775	828	$M_2$ c			
2.6	5.8	2.5		1.5	3.8	1.6	5.0	$n_{2 \text{ Eck}}$	20.50	4779	53.148
32	44	66		32	47	66	78	$n_{2 \text{ th}}$			
32	44	46		32	38	38	38				
								$M_2$ c			
								$n_{2 \text{ Eck}}$	13.20	4546	59.321
								$n_{2 \text{ th}}$			
2024	879	2010		3462	1354	3098	924	$M_2$ c			
2.6	5.7	2.5		1.5	3.8	1.6	4.9	$n_{2 \text{ Eck}}$	13.20	5267	59.321
29	40	59		29	42	59	70	$n_{2 \text{ th}}$			
29	39	41		29	34	34	34				
2369	1035	2351	754	4042	1589	3618	1087	$M_2$ c			
2.1	4.6	2.0	5.6	1.2	3.0	1.3	3.9	$n_{2 \text{ Eck}}$	11.50	4917	69.042
25	34	51	60	25	36	51	60	$n_{2 \text{ th}}$			
25	34	35	35	25	29	29	29				
2692	1176	2672	857	4593	1805	4112	1236	$M_2$ c			
2.1	4.6	2.0	5.6	1.2	3.0	1.3	3.9	$n_{2 \text{ Eck}}$	11.40	5587	78.457
22	30	45	53	22	32	45	53	$n_{2 \text{ th}}$			
22	30	31	31	22	26	26	26				
								$M_2$ c			
								$n_{2 \text{ Eck}}$	6.57	4793	93.541
								$n_{2 \text{ th}}$			
3221	1415	3197	1032					$M_2$ c			
1.7	3.8	1.6	4.6					$n_{2 \text{ Eck}}$	6.57	5524	93.541
18	25	38	44					$n_{2 \text{ th}}$			
18	25	26	26								

M ... [Nm]  
n ... [r/min]  
J ... [kgcm<sup>2</sup>]

P ... [kW]  
I ... [A]  
i [-]  
c [-]

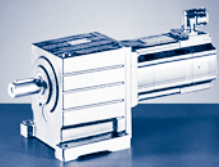

# GST [Nm]

## GST□□-□A (MCA)

$M_{2GN} \leq 5920 \text{ Nm}$

GST14-3A				14LC16	14LC20	14LC35	14LC41	17NC17	17NC23	17NC35	17NC41
				...F10	...S00	...F10	...S00	...F10	...S00	...F10	...S00
i	$M_{2GN}$	$J_G$	$M_1$	12.00	6.70	10.80	5.40	21.50	10.80	19.00	9.50
			$n_1$	1635	2000	3455	4100	1680	2300	3480	4110
			$I_{M400}$	4.8	3.3	9.1	5.8	8.5	5.5	15.8	10.2
			$P_N$	2.10	1.40	3.90	2.30	3.80	2.60	6.90	4.10
			$J_M$	19.32	19.24	19.24	19.24	36.04	36.04	36.04	36.04
96.157	5882	10.40	$M_2$					1935	941	1706	
			c				3.0	5.9	3.2		
			$n_{2 \text{ Eck}}$				18	24	36		
			$n_{2 \text{ th}}$				17	24	32		
106.296	5447	6.52	$M_2$	1175		1054					
			c	4.5		4.7					
			$n_{2 \text{ Eck}}$	15		33					
			$n_{2 \text{ th}}$	15		33					
106.296	5920	6.52	$M_2$					2145	1047	1891	919
			c					2.7	5.4	2.9	5.5
			$n_{2 \text{ Eck}}$					16	22	33	39
			$n_{2 \text{ th}}$					16	22	29	29
130.278	5920	6.00	$M_2$	1448		1300		2643	1297	2331	1139
			c	4.0		4.2		2.2	4.4	2.4	4.5
			$n_{2 \text{ Eck}}$	13		27		13	18	27	32
			$n_{2 \text{ th}}$	13		27		13	18	24	24
139.211	5736	4.42	$M_2$	1553		1395		2830	1392	2497	1223
			c	3.6		3.8		2.0	4.0	2.2	4.1
			$n_{2 \text{ Eck}}$	12		25		12	17	25	30
			$n_{2 \text{ th}}$	12		25		12	17	22	22
158.194	5920	4.40	$M_2$	1771	962	1591		3222	1588	2844	1395
			c	3.3	5.8	3.5		1.8	3.6	2.0	3.7
			$n_{2 \text{ Eck}}$	10	13	22		11	15	22	26
			$n_{2 \text{ th}}$	10	13	22		11	15	20	20
171.111	5920	5.49	$M_2$	1921	1045	1725		3491	1723	3081	1514
			c	3.0	5.4	3.2		1.7	3.4	1.8	3.4
			$n_{2 \text{ Eck}}$	10	12	20		10	13	20	24
			$n_{2 \text{ th}}$	10	12	20		10	13	18	18
204.722	5920	2.86	$M_2$	2310	1263	2076	1012	4188	2073	3697	1822
			c	2.5	4.5	2.7	5.1	1.4	2.8	1.5	2.9
			$n_{2 \text{ Eck}}$	8	10	17	20	8	11	17	20
			$n_{2 \text{ th}}$	8	10	17	18	8	11	15	15
236.622	5779	2.65	$M_2$	2682	1470	2410	1179	4852	2407	4284	2116
			c	2.1	3.8	2.3	4.3	1.2	2.4	1.3	2.4
			$n_{2 \text{ Eck}}$	7	9	15	17	7	10	15	17
			$n_{2 \text{ th}}$	7	8	15	15	7	10	13	13
248.458	5920	2.06	$M_2$	2817	1546	2532	1240	5097	2529	4500	2224
			c	2.1	3.7	2.2	4.2	1.2	2.3	1.3	2.4
			$n_{2 \text{ Eck}}$	7	8	14	17	7	9	14	17
			$n_{2 \text{ th}}$	7	8	14	14	7	9	13	13
268.889	5920	2.65	$M_2$	3054	1678	2745	1346	5521	2742	4875	2411
			c	1.9	3.4	2.0	3.8	1.1	2.1	1.2	2.2
			$n_{2 \text{ Eck}}$	6	7	13	15	6	9	13	15
			$n_{2 \text{ th}}$	6	7	13	13	6	9	12	12
326.333	5920	1.92	$M_2$	3720	2049	3344	1646		3341		2938
			c	1.6	2.8	1.7	3.2		1.8		1.8
			$n_{2 \text{ Eck}}$	5	6	11	13		7		13
			$n_{2 \text{ th}}$	5	6	11	11		7		10
363.000	5779	2.45	$M_2$	4146	2288	3728	1838				
			c	1.4	2.5	1.5	2.8				
			$n_{2 \text{ Eck}}$	5	6	10	11				
			$n_{2 \text{ th}}$	5	6	10	10				

$M \dots$  [Nm]  
 $n \dots$  [r/min]  
 $J \dots$  [kgcm<sup>2</sup>]

$P \dots$  [kW]  
 $I \dots$  [A]  
 $i$  [-]  
 $c$  [-]

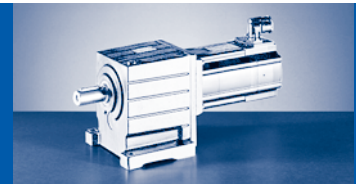

$M_{2GN} \leq 5920 \text{ Nm}$

195C17	195C23	195C35	195C42	21XC17	21XC25	21XC35	21XC42	GST14-3A			
...F10	...500	...F10	...500	...F10	...500	...F10	...500	$M_1$	$J_G$	$M_{2GN}$	$i$
36.30	16.30	36.00	12.00	61.40	24.60	55.00	17.00	$n_1$			
1700	2340	3510	4150	1710	2490	3520	4160	$I_{M400}$			
13.9	8.2	28.7	14.0	22.5	13.5	42.5	19.8	$P_N$			
6.40	4.00	13.20	5.20	11.00	6.40	20.30	7.40	$J_M$			
72.12	72.12	72.04	72.12	180.04	180.04	180.04	180.04	$M_2$			
3309	1452	3284	1059	5640	2223	5049	1523	$c$	10.40	5882	96.157
1.8	3.9	1.7	4.8	1.0	2.6	1.1	3.4	$n_{2 \text{ Eck}}$			
18	24	37	43	18	26	37	43	$n_{2 \text{ th}}$			
18	24	25	25	18	21	21	21	$M_2$			
								$c$	6.52	5447	106.296
								$n_{2 \text{ Eck}}$			
								$n_{2 \text{ th}}$			
3664	1611	3637	1176					$M_2$			
1.6	3.6	1.5	4.4					$c$	6.52	5920	106.296
16	22	33	39					$n_{2 \text{ Eck}}$			
16	22	23	23					$n_{2 \text{ th}}$			
4505	1989	4470	1454					$M_2$			
1.3	2.9	1.3	3.6					$c$	6.00	5920	130.278
13	18	27	32					$n_{2 \text{ Eck}}$			
13	18	19	19					$n_{2 \text{ th}}$			
4820	2131	4783	1559					$M_2$			
1.2	2.7	1.1	3.2					$c$	4.42	5736	139.211
12	17	25	30					$n_{2 \text{ Eck}}$			
12	17	18	18					$n_{2 \text{ th}}$			
5483	2428	5441	1778					$M_2$			
1.1	2.4	1.0	2.9					$c$	4.40	5920	158.194
11	15	22	26					$n_{2 \text{ Eck}}$			
11	15	15	15					$n_{2 \text{ th}}$			
	2631		1927					$M_2$			
	2.2		2.7					$c$	5.49	5920	171.111
	14		24					$n_{2 \text{ Eck}}$			
	14		14					$n_{2 \text{ th}}$			
								$M_2$			
								$c$	2.86	5920	204.722
								$n_{2 \text{ Eck}}$			
								$n_{2 \text{ th}}$			
								$M_2$			
								$c$	2.65	5779	236.622
								$n_{2 \text{ Eck}}$			
								$n_{2 \text{ th}}$			
								$M_2$			
								$c$	2.06	5920	248.458
								$n_{2 \text{ Eck}}$			
								$n_{2 \text{ th}}$			
								$M_2$			
								$c$	2.65	5920	268.889
								$n_{2 \text{ Eck}}$			
								$n_{2 \text{ th}}$			
								$M_2$			
								$c$	1.92	5920	326.333
								$n_{2 \text{ Eck}}$			
								$n_{2 \text{ th}}$			
								$M_2$			
								$c$	2.45	5779	363.000
								$n_{2 \text{ Eck}}$			
								$n_{2 \text{ th}}$			

M ... [Nm]  
n ... [r/min]  
J ... [kgcm<sup>2</sup>]

P ... [kW]  
I ... [A]  
i [-]  
c [-]

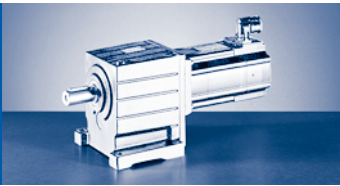

# GST [Nm]

## GST□□-□A (MCA)

$M_{2GN} \leq 5920 \text{ Nm}$

GST14-3A				14LC16	14LC20	14LC35	14LC41	17NC17	17NC23	17NC35	17NC41
				...F10	...S00	...F10	...S00	...F10	...S00	...F10	...S00
i	$M_{2GN}$	$J_G$	$M_1$	12.00	6.70	10.80	5.40	21.50	10.80	19.00	9.50
			$n_1$	1635	2000	3455	4100	1680	2300	3480	4110
			$I_{M400}$	4.8	3.3	9.1	5.8	8.5	5.5	15.8	10.2
			$P_N$	2.10	1.40	3.90	2.30	3.80	2.60	6.90	4.10
			$J_M$	19.32	19.24	19.24	19.24	36.04	36.04	36.04	36.04
412.500	5920	1.78	$M_2$	4718	2607	4243	2095				
			c	1.3	2.2	1.3	2.5				
			$n_{2Eck}$	4	5	8	10				
			$n_{2th}$	4	5	8	9				

M ... [Nm]  
 n ... [r/min]  
 J ... [kgcm<sup>2</sup>]

P ... [kW]  
 I ... [A]  
 i [-]  
 c [-]

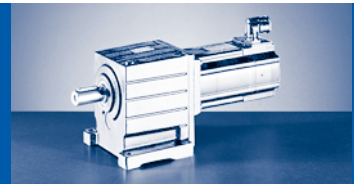

$M_{2\text{ GN}} \leq 5920 \text{ Nm}$

19SC17	19SC23	19SC35	19SC42	21XC17	21XC25	21XC35	21XC42	GST14-3A			
...F10	...500	...F10	...500	...F10	...500	...F10	...500	$M_1$	$J_G$	$M_{2\text{ GN}}$	$i$
36.30	16.30	36.00	12.00	61.40	24.60	55.00	17.00	$n_1$			
1700	2340	3510	4150	1710	2490	3520	4160	$I_{M400}$			
13.9	8.2	28.7	14.0	22.5	13.5	42.5	19.8	$P_N$			
6.40	4.00	13.20	5.20	11.00	6.40	20.30	7.40	$J_M$			
72.12	72.12	72.04	72.12	180.04	180.04	180.04	180.04	$M_2$			
								$c$	1.78	5920	412.500
								$n_{2\text{ Eck}}$			
								$n_{2\text{ th}}$			

M ... [Nm]  
n ... [r/min]  
J ... [kgcm<sup>2</sup>]

P ... [kW]  
I ... [A]  
i [-]  
c [-]

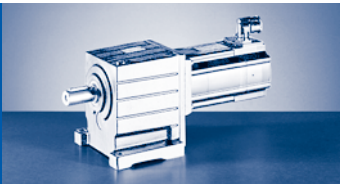

# GST [mm]

## GST□□-1S (MCS)

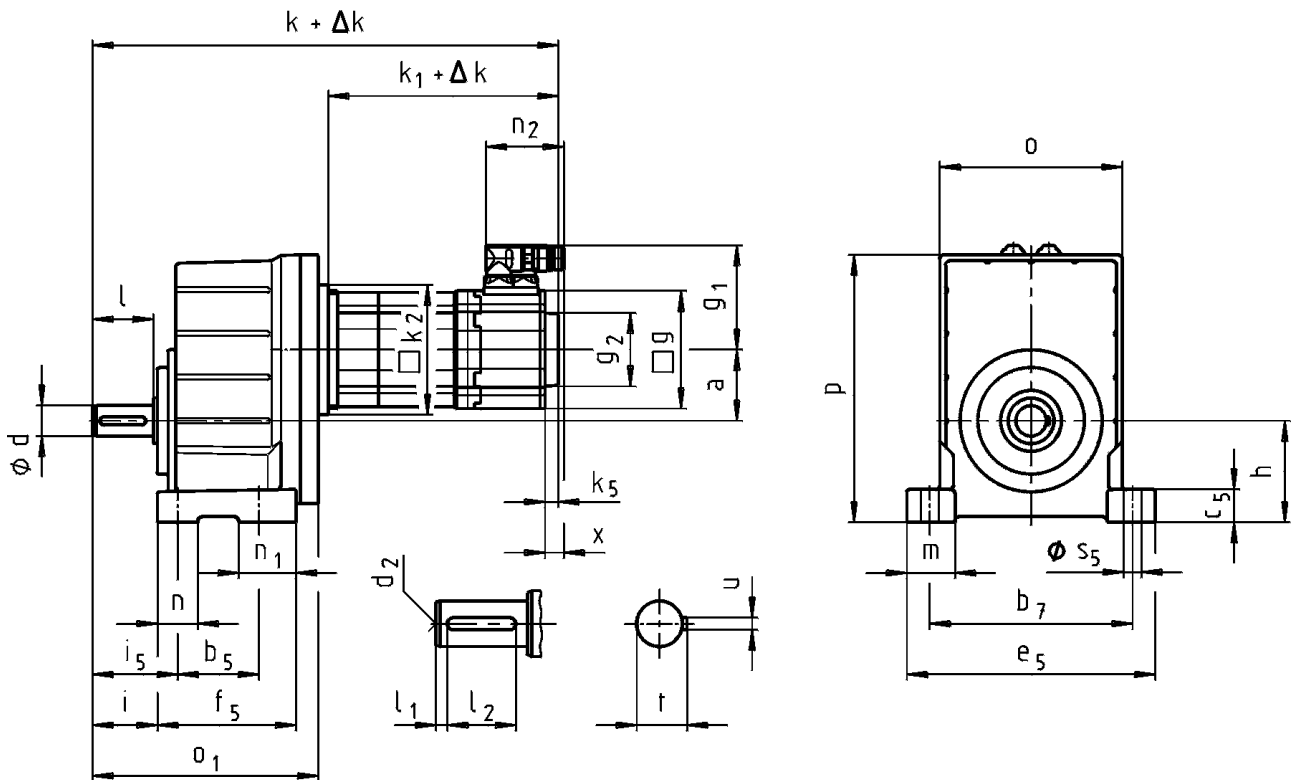

### GST□□-1S VBR ... RSO

		06C C41	06F C41	06I C41	09D C41	09F C38	09H C41	09L C41	12D C20	12D C41	12H C15	12H C30	12H C35	12L C20	12L C41	
GST04...	k	279	309	339	331	351	371	411								
GST05...	k	300	330	360	352	372	392	432	369		409			449		
GST06...	k	323	353	383	375	395	415	455	392		432			472		
GST07...	k				404	424	444	484	421		461			501		
GST09...	k								464		504			544		
...RSO B0 <sup>1)</sup>	$\Delta k$	0														
...RSO P□ <sup>2)</sup>	$\Delta k$	19				20										
...RSO	$k_1$	132	162	192	183	203	223	263	188		228			268		
	$k_2$	66			91								118	145 <sup>2)</sup>		
	g	62			89								116			
	$k_5$	0			13								14			
	$g_2$	□ 62			Ø 67								Ø 72			
	$g_1$	76			90								105			
	$n_2$	64							78							
	x					21								18		

<sup>1)</sup> → 801 - SRS/SRM/ECN/EQN/EQI/C20

<sup>2)</sup> GST05: 12DC20 ... 12LC41

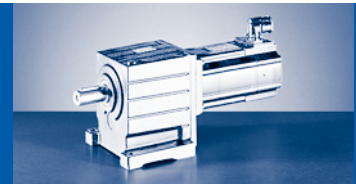

### GST□□-1S VBR ... RSO

		14D C15	14D C36	14H C15	14H C32	14L C15	14L C32	14P C14	14P C32	19F C14	19F C30	19J C14	19J C30	19P C14	19P C30		
GST06...	k	408		448		488		528									
GST07...	k	437		477		517		557		476		516		576			
GST09...	k	480		520		560		600		519		559		619			
...RSO B0 <sup>1)</sup>	Δ k	0															
...RSO P□ <sup>1)</sup>	Δ k	28						34			44						
	k <sub>1</sub>	201		241		281		321		220		260		320			
	k <sub>2</sub>	145						195									
	g	143						192									
...RSO	k <sub>5</sub>	24						15									
	g <sub>2</sub>	Ø 78															
	g <sub>1</sub>	116				147		116	147	141	172	141	172	141	172	141	172
	n <sub>2</sub>	78				94		78	94	78	94	78	94	78	94	78	94
	x	16				38		16	38	16	36	16	36	16	36	16	36

<sup>1)</sup> →  801 - SRS/SRM/ECN/EQN/EQI/C20

### GST□□-1S VBR

	o		o <sub>1</sub>		p		h		a	
GST04...	100		134		138		50		36	
GST05...	115		165		168		63		45	
GST06...	145		191		211		80		56	
GST07...	180		223		264		100		70	
GST09...	222		271		329		125		89	

	d	l	l <sub>1</sub>	l <sub>2</sub>	d <sub>2</sub>	u	t	b <sub>5</sub>	b <sub>7</sub>	c <sub>5</sub>	e <sub>5</sub>	f <sub>5</sub>	i	i <sub>5</sub>	m	n	n <sub>1</sub>	s <sub>5</sub>
GST04...	16	32	6	20	M5	5	18	55	105	17	128	80	35	45	24	20	25	9
GST05...	20	40		28	M6	6	22.5	70	125	22	154	99	43	56	32	26	29	11
GST06...	25	50	4	40	M10	8	28	72	160	27	194	115	53	68	37	30	43	13.5
GST07...	30	60	7.5	45				33	80	200	35	245	137	64	84	48	40	57
GST09...	40	80	8.5	63	M16	12	43	105	245	43	296	161	84	107	51	45	56	

d ≤ 50 mm: k6; d > 50 mm: m6

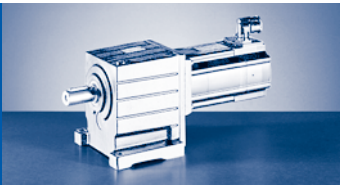

# GST [mm]

## GST□□-1S (MCS)

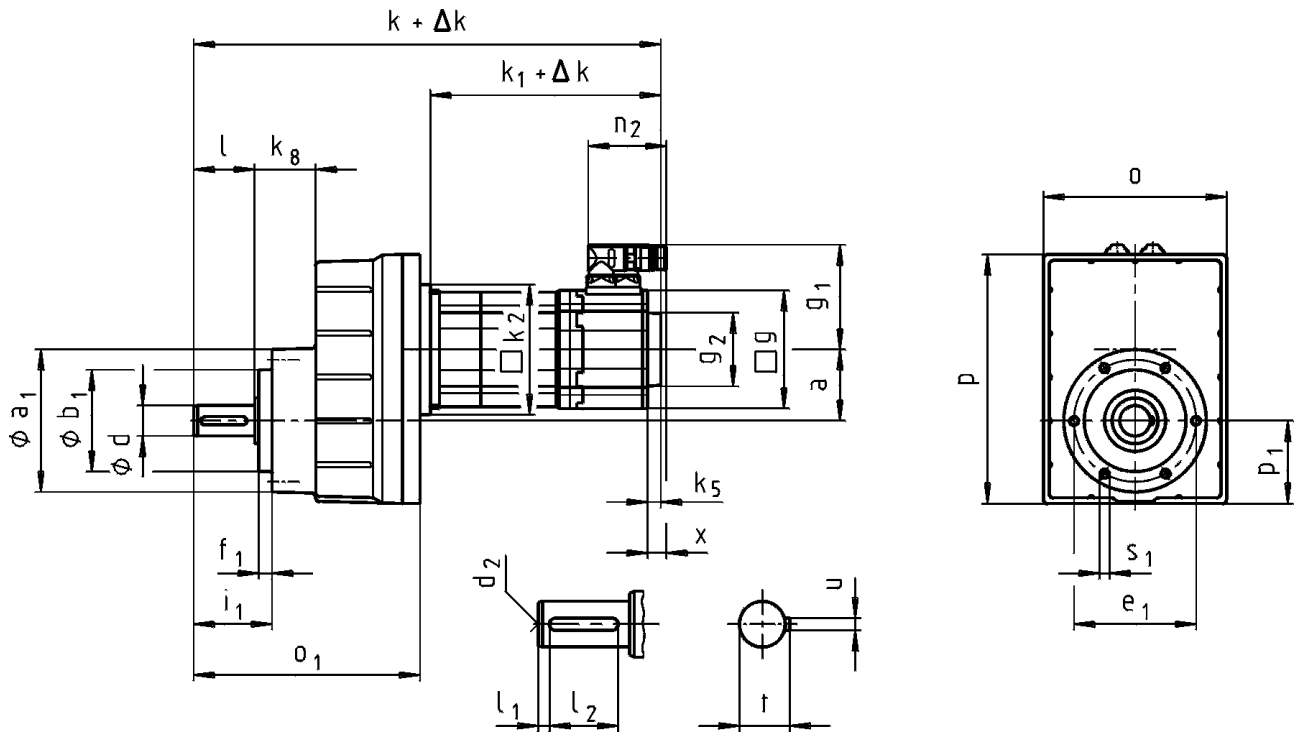

### GST□□-1S VCR ... RSO

		06C C41	06F C41	06I C41	09D C41	09F C38	09H C41	09L C41	12D C20	12D C41	12H C15	12H C30	12H C35	12L C20	12L C41		
GST04...	k	279	309	339	331	351	371	411									
GST05...	k	300	330	360	352	372	392	432	369			409			449		
GST06...	k	323	353	383	375	395	415	455	392			432			472		
GST07...	k				404	424	444	484	421			461			501		
GST09...	k								464			504			544		
...RSO B0 <sup>1)</sup>	Δ k	0															
...RSO P□ <sup>1)</sup>	Δ k	19				20											
	k <sub>1</sub>	132	162	192	183	203	223	263	188			228			268		
	k <sub>2</sub>	66			91							118	145 <sup>2)</sup>				
	g	62			89							116					
...RSO	k <sub>5</sub>	0			13							14					
	g <sub>2</sub>	□ 62			Ø 67							Ø 72					
	g <sub>1</sub>	76			90							105					
	n <sub>2</sub>	64								78							
	x					21								18			

<sup>1)</sup> → 801 - SRS/SRM/ECN/EQN/EQI/C20

<sup>2)</sup> GST05: 12DC20 ... 12LC41

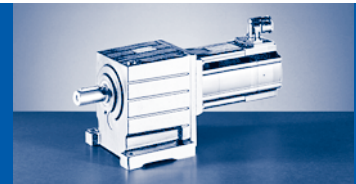

GST□□-1S VCR ... RSO

		14D C15	14D C36	14H C15	14H C32	14L C15	14L C32	14P C14	14P C32	19F C14	19F C30	19J C14	19J C30	19P C14	19P C30				
GST06...	k	408		448		488		528											
GST07...	k	437		477		517		557		476		516		576					
GST09...	k	480		520		560		600		519		559		619					
...RSO B0 <sup>1)</sup>	Δ k	0																	
...RSO P□ <sup>1)</sup>	Δ k	28						34			44								
	k <sub>1</sub>	201		241		281		321		220		260		320					
	k <sub>2</sub>	145						195											
	g	143						192											
...RSO	k <sub>5</sub>	24						15											
	g <sub>2</sub>	Ø 78																	
	g <sub>1</sub>	116				147		116		147		141		172		141		172	
	n <sub>2</sub>	78				94		78		94		78		94		78		94	
	x	16				38		16		38		16		36		16		36	

<sup>1)</sup> → 801 - SRS/SRM/ECN/EQN/EQI/C20

GST□□-1S VCR

	o	o <sub>1</sub>	p	p <sub>1</sub>	a	k <sub>g</sub>
GST04...	100	134	129	41	36	35
GST05...	115	165	156	51	45	43
GST06...	145	191	194	63	56	48
GST07...	180	223	245	82	70	60
GST09...	222	271	304	101	89	74

	d	l	l <sub>1</sub>	l <sub>2</sub>	d <sub>2</sub>	u	t	a <sub>1</sub>	b <sub>1</sub>	e <sub>1</sub>	f <sub>1</sub>	i <sub>1</sub>	s <sub>1</sub>
									h7				6x60°
GST04...	16	32	6	20	M5	5	18	72	48	61	8	43	M5x10
GST05...	20	40		28	M6	6	22.5	88	58	74	9	52	M6x12
GST06...	25	50	4	40	M10	8	28	109	70	90	11	64	M8x14
GST07...	30	60	7.5	45			33	140	100	120	13	77	M10x18
GST09...	40	80	8.5	63	M16	12	43	174	120	145	15	100	M12x20

d ≤ 50 mm: k6; d > 50 mm: m6



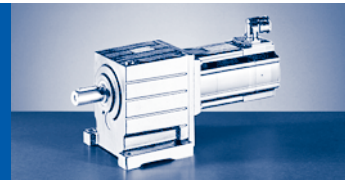

**GST□□-1S VCK ... RSO**

		14D C15	14D C36	14H C15	14H C32	14L C15	14L C32	14P C14	14P C32	19F C14	19F C30	19J C14	19J C30	19P C14	19P C30	
GST06...	k	408		448		488		528								
GST07...	k	437		477		517		557		476		516		576		
GST09...	k	480		520		560		600		519		559		619		
...RSO B0 <sup>1)</sup>	Δ k	0														
...RSO P□ <sup>1)</sup>	Δ k	28						34			44					
	k <sub>1</sub>	201		241		281		321		220		260		320		
	k <sub>2</sub>	145						195								
	g	143						192								
...RSO	k <sub>5</sub>	24						15								
	g <sub>2</sub>	Ø 78														
	g <sub>1</sub>	116				147		116	147	141	172	141	172	141	172	
	n <sub>2</sub>	78				94		78	94	78	94	78	94	78	94	
	x	16				38		16	38	16	36	16	36	16	36	

<sup>1)</sup> → 801 - SRS/SRM/ECN/EQN/EQI/C20

**GST□□-1S VCK**

	o	o <sub>1</sub>	p <sub>1</sub>	p <sub>3</sub>	a	k <sub>g</sub>
GST04...	100	134	41	88	36	35
GST05...	115	165	51	105	45	43
GST06...	145	191	63	131	56	48
GST07...	180	223	82	164	70	60
GST09...	222	271	101	204	89	74

	d	l	l <sub>1</sub>	l <sub>2</sub>	d <sub>2</sub>	u	t	a <sub>2</sub>	b <sub>2</sub>	c <sub>2</sub>	e <sub>2</sub>	f <sub>2</sub>	i <sub>2</sub>	s <sub>2</sub>	
									j7					4x90°	
GST04...	16	32	6	20	M5	5	18	120	80	10	100	3	32	7	
								140	95					3.5	9
								160	110					3	7
GST05...	20	40	6	28	M6	6	22.5	120	80	10	100	3	40	7	
								140	95					3.5	9
								160	110					3	11
GST06...	25	50	4	40	M10	8	28	160	110	12	130	3.5	50	9	
								200	130					3	11
								250	180					4	13.5
GST07...	30	60	7.5	45	M10	8	33	200	130	14	165	4	60	11	
								250	180					15	13.5
GST09...	40	80	8.5	63	M16	12	43	300	230	18	265	4	80	13.5	
								300	230					18	265

d ≤ 50 mm: k6; d > 50 mm: m6

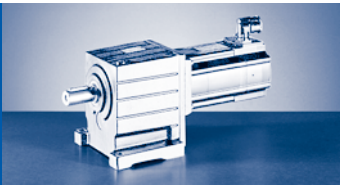

# GST [mm]

## GST□□-2S (MCS)

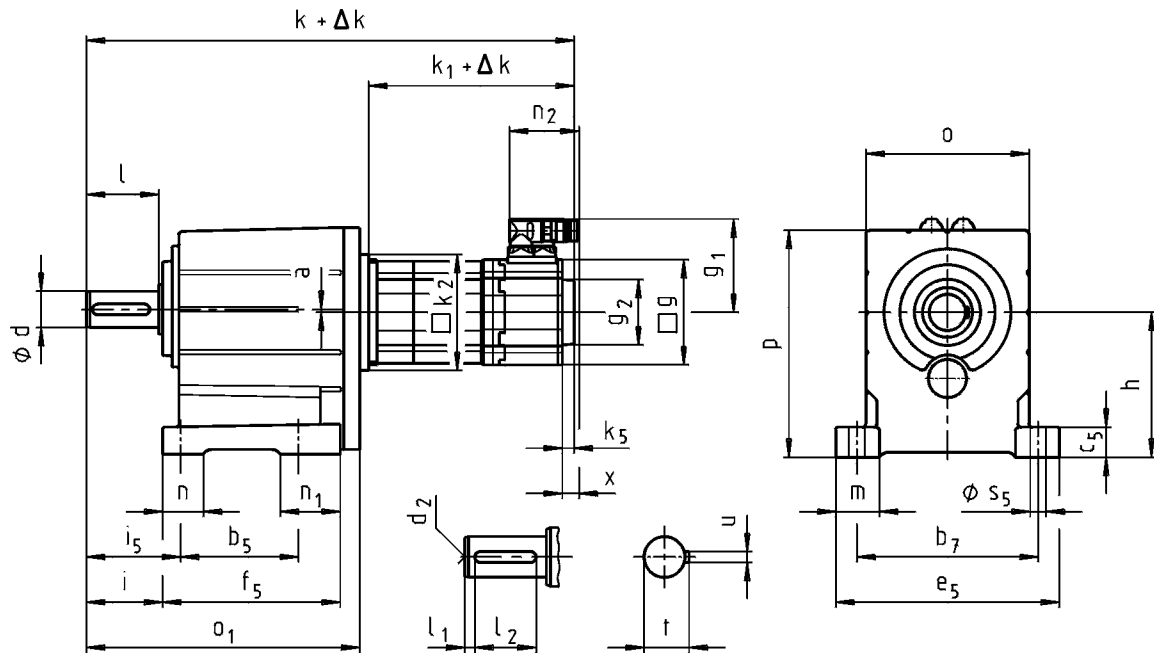

### GST□□-2S VBR ... RSO

		06C C41	06F C41	06I C41	09D C41	09F C38	09H C41	09L C41	12D C20	12D C41	12H C15	12H C30	12H C35	12L C20	12L C41	
GST03...	k	279 <sup>2)</sup>	309 <sup>2)</sup>	339 <sup>2)</sup>												
	k	291 <sup>3)</sup>	321 <sup>3)</sup>	351 <sup>3)</sup>												
GST04...	k	319	349	379	371	391	411	451								
GST05...	k	349	379	409	401	421	441	481	418		458				498	
GST06...	k	375	405	435	427	447	467	507	444		484				524	
GST07...	k				483	503	523	563	500		540				580	
GST09...	k								563		603				643	
...RSO B0 <sup>1)</sup>	$\Delta k$	0														
...RSO P□ <sup>1)</sup>	$\Delta k$	19			20											
	k <sub>1</sub>	132	162	192	183	203	223	263	188		228				268	
	k <sub>2</sub>	66			91							118	145 <sup>4)</sup>			
	g	62			89							116				
...RSO	k <sub>5</sub>	0			13							14				
	g <sub>2</sub>	□ 62			Ø 67							Ø 72				
	g <sub>1</sub>	76			90							105				
	n <sub>2</sub>	64								78						
	x				21						18					

<sup>1)</sup> → 801 - SRS/SRM/ECN/EQN/EQI/C20

<sup>2)</sup> d = 14

<sup>3)</sup> d = 20

<sup>4)</sup> GST05: 12DC20 ... 12LC41

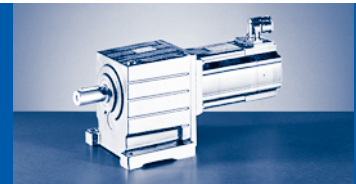

GST□□-2S VBR ... RSO

		14D C15	14D C36	14H C15	14H C32	14L C15	14L C32	14P C14	14P C32	19F C14	19F C30	19J C14	19J C30	19P C14	19P C30	
GST06...	k	460		500		540		580								
GST07...	k	516		556		596		636		555		595		655		
GST09...	k	579		619		659		699		618		658		718		
GST11...	k	636		676		716		756		675		715		775		
GST14...	k									765		805		865		
...RSO B0 <sup>1)</sup>	Δ k	0														
...RSO P□ <sup>1)</sup>	Δ k	28						34			44					
	k <sub>1</sub>	201		241		281		321		220		260		320		
	k <sub>2</sub>	145						195								
	g	143						192								
...RSO	k <sub>5</sub>	24						15								
	g <sub>2</sub>	Ø 78														
	g <sub>1</sub>	116				147		116	147	141	172	141	172	141	172	
	n <sub>2</sub>	78				94		78	94	78	94	78	94	78	94	
	x	16				38		16	38	16	36	16	36	16	36	

1) → 801 - SRS/SRM/ECN/EQN/EQI/C20

GST□□-2S VBR

	o	o <sub>1</sub>	p	h	a
GST03...	90	127 <sup>2)</sup> 139 <sup>3)</sup>	101	65	2
GST04...	100	174	132	80	0
GST05...	115	214	159	100	1
GST06...	145	243	198	125	2
GST07...	180	302	251	160	3
GST09...	222	370	311	200	4
GST11...	270	433	385	250	
GST14...	328	533	479	315	6

2) d = 14

3) d = 20

	d	l	l <sub>1</sub>	l <sub>2</sub>	d <sub>2</sub>	u	t	b <sub>5</sub>	b <sub>7</sub>	c <sub>5</sub>	e <sub>5</sub>	f <sub>5</sub>	i	i <sub>5</sub>	m	n	n <sub>1</sub>	s <sub>5</sub>
GST03...	14	28	4	20	M5	5	16	60	91	11	105	84	34	40	20	-	-	6.6
		20	40	5	28	M6	6						22.5	46				
GST04...	20	40	5	28	M6	6	22.5	76	105	18	129	112	43	53	25	20	36	9
GST05...	25	50	4	40	M10	8	28	90	125	23	155	139	53	66	33	26	49	11
GST06...	30	60	6	45				33	106	160	28	196	157	64	79	38	35	52
GST07...	40	80	7	63	M16	12	43	130	200	34	247	196	84	104	49	45	66	18
GST09...	50	100	8	80				14	53.5	165	245	44	298	239	105	127.5	54	
GST11...	60	120		100	M20	18	64	200	200	300	54	368	280	125	155	69	65	80
GST14...	80	160	15	125					22	85	250	380	65	460	340	165	200	85

d ≤ 50 mm: k6; d > 50 mm: m6

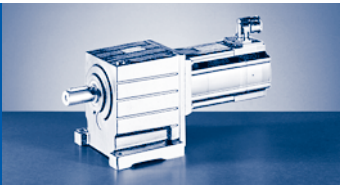

# GST [mm]

## GST□□-2S (MCS)

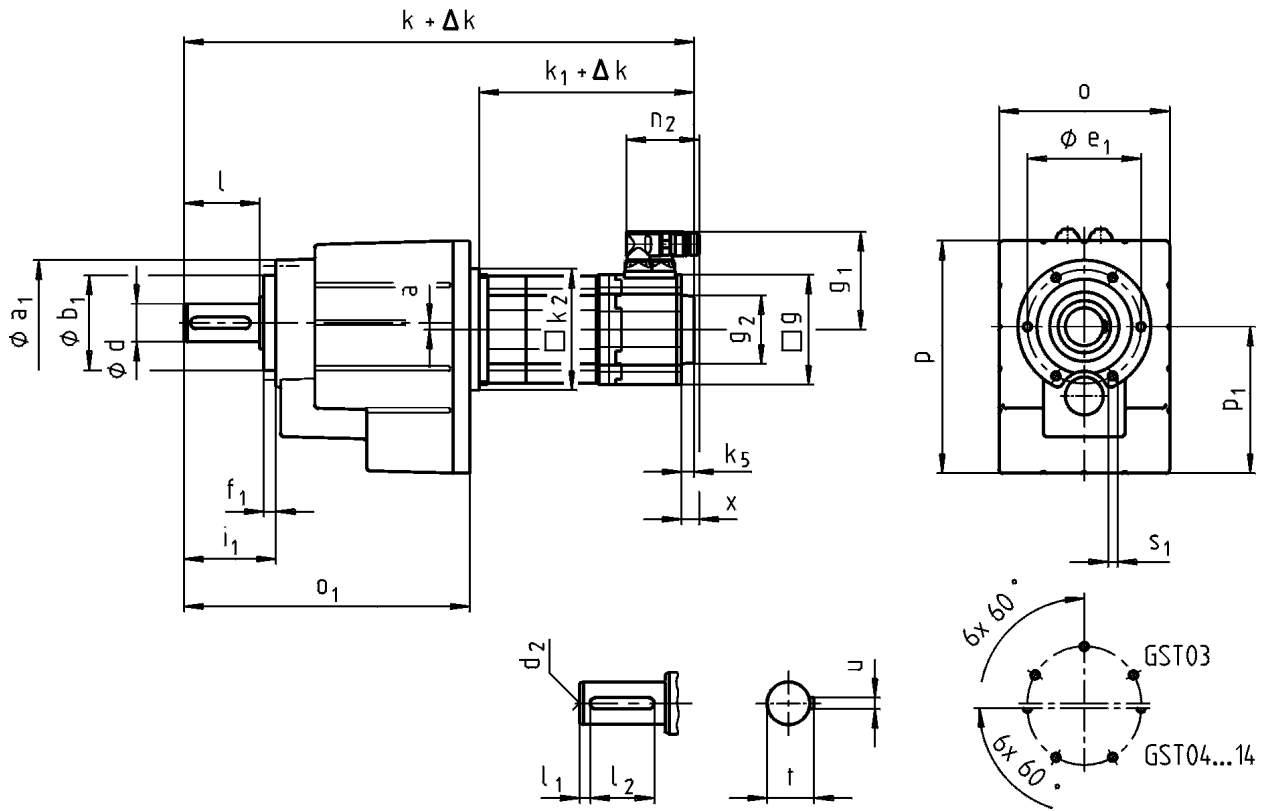

### GST□□-2S VCR ... RSO

		06C C41	06F C41	06I C41	09D C41	09F C38	09H C41	09L C41	12D C20	12D C41	12H C15	12H C30	12H C35	12L C20	12L C41
GST03...	k	279 <sup>2)</sup>	309 <sup>2)</sup>	339 <sup>2)</sup>											
	k	291 <sup>3)</sup>	321 <sup>3)</sup>	351 <sup>3)</sup>											
GST04...	k	319	349	379	371	391	411	451							
GST05...	k	349	379	409	401	421	441	481	418			458			498
GST06...	k	375	405	435	427	447	467	507	444			484			524
GST07...	k				483	503	523	563	500			540			580
GST09...	k								563			603			643
...RSO B0 <sup>1)</sup>	Δ k	0													
...RSO P□ <sup>1)</sup>	Δ k	19				20									
...RSO	k <sub>1</sub>	132	162	192	183	203	223	263	188			228			268
	k <sub>2</sub>	66			91				118				145 <sup>4)</sup>		
	g	62			89				116						
	k <sub>5</sub>	0			13				14						
	g <sub>2</sub>	□ 62			Ø 67				Ø 72						
	g <sub>1</sub>	76			90				105						
	n <sub>2</sub>	64							78						
	x	21								18					

<sup>1)</sup> → 801 - SRS/SRM/ECN/EQN/EQI/C20

<sup>2)</sup> d = 14

<sup>3)</sup> d = 20

<sup>4)</sup> GST05: 12DC20 ... 12LC41

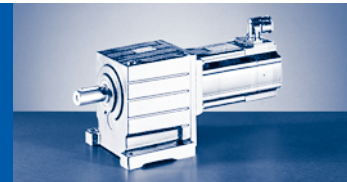

### GST□□-2S VCR ... RSO

		14D C15	14D C36	14H C15	14H C32	14L C15	14L C32	14P C14	14P C32	19F C14	19F C30	19J C14	19J C30	19P C14	19P C30				
GST06...	k	460		500		540		580											
GST07...	k	516		556		596		636		555		595		655					
GST09...	k	579		619		659		699		618		658		718					
GST11...	k	636		676		716		756		675		715		775					
GST14...	k									765		805		865					
...RSO B0 <sup>1)</sup>	Δ k	0																	
...RSO P□ <sup>1)</sup>	Δ k	28						34			44								
	k <sub>1</sub>	201		241		281		321		220		260		320					
	k <sub>2</sub>	145						195											
	g	143						192											
...RSO	k <sub>5</sub>	24						15											
	g <sub>2</sub>	Ø 78																	
	g <sub>1</sub>	116				147		116		147		141		172		141		172	
	n <sub>2</sub>	78				94		78		94		78		94		78		94	
	x	16				38		16		38		16		36		16		36	

1) → 801 - SRS/SRM/ECN/EQN/EQI/C20

### GST□□-2S VCR

	o	o <sub>1</sub>	p	p <sub>1</sub>	a
GST03...	90	127 <sup>2)</sup> 139 <sup>3)</sup>	100	64	2
GST04...	100	174	129	77	0
GST05...	115	214	156	98	1
GST06...	145	243	194	121	2
GST07...	180	302	245	155	3
GST09...	222	370	304	194	4
GST11...	270	433	378	243	
GST14...	328	533	470	306	6

2) d = 14

3) d = 20

	d	l	l <sub>1</sub>	l <sub>2</sub>	d <sub>2</sub>	u	t	a <sub>1</sub>	b <sub>1</sub>	e <sub>1</sub>	f <sub>1</sub>	i <sub>1</sub>	s <sub>1</sub>
									h7				6x60°
GST03...	14	28	4	20	M5	5	16	71	48	61	8	39	M5x10
GST04...	20	40	5	28	M6	6	22.5					51	
GST05...	25	50	4	40	M10	8	28	88	58	74	9	62	M6x12
GST06...	30	60	6	45			33	109	70	90	10	74	M8x14
GST07...	40	80	7	63	M16	12	43	140	100	120	13	97	M10x18
GST09...	50	100	8	80			14	53.5	174	120	145	15	120
GST11...	60	120		100	M20	18	64	215	150	185	18	143	M16x26
GST14...	80	160	15	125				22	85	265	195	230	22

d ≤ 50 mm: k6; d > 50 mm: m6

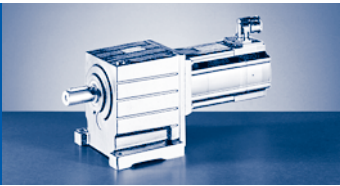

# GST [mm]

## GST□□-2S (MCS)

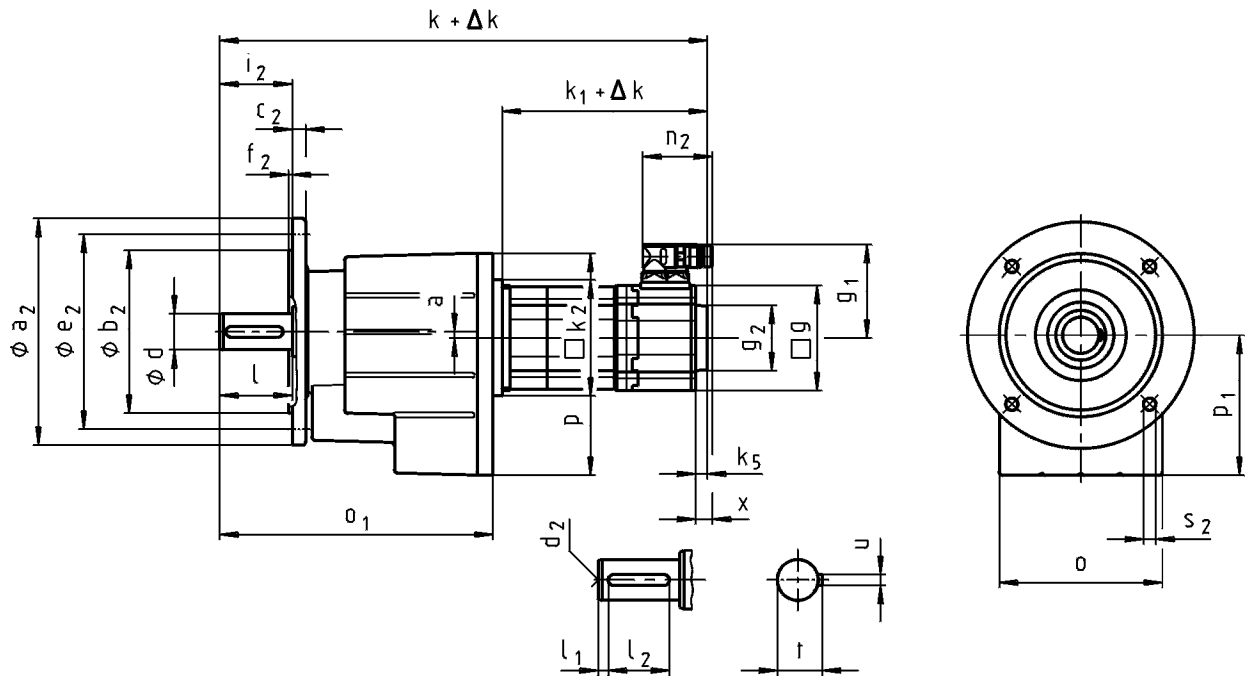

### GST□□-2S VCK ... RSO

		06C C41	06F C41	06I C41	09D C41	09F C38	09H C41	09L C41	12D C20	12D C41	12H C15	12H C30	12H C35	12L C20	12L C41	
GST03...	k	279 <sup>2)</sup>	309 <sup>2)</sup>	339 <sup>2)</sup>												
	k	291 <sup>3)</sup>	321 <sup>3)</sup>	351 <sup>3)</sup>												
GST04...	k	319	349	379	371	391	411	451								
GST05...	k	349	379	409	401	421	441	481	418			458			498	
GST06...	k	375	405	435	427	447	467	507	444			484			524	
GST07...	k				483	503	523	563	500			540			580	
GST09...	k								563			603			643	
...RSO B0 <sup>1)</sup>	Δ k	0														
...RSO P□ <sup>1)</sup>	Δ k	19				20										
	k <sub>1</sub>	132	162	192	183	203	223	263	188			228			268	
	k <sub>2</sub>	66			91								118	145 <sup>4)</sup>		
	g	62			89								116			
...RSO	k <sub>5</sub>	0			13								14			
	g <sub>2</sub>	□ 62			Ø 67								Ø 72			
	g <sub>1</sub>	76			90								105			
	n <sub>2</sub>	64							78							
	x					21								18		

<sup>1)</sup> → 801 - SRS/SRM/ECN/EQN/EQI/C20

<sup>2)</sup> d = 14

<sup>3)</sup> d = 20

<sup>4)</sup> GST05: 12DC20 ... 12LC41

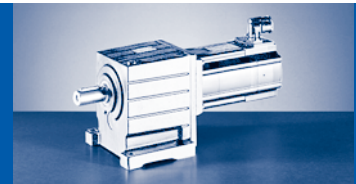

GST□□-2S VCK ... RSO

		14D C15	14D C36	14H C15	14H C32	14L C15	14L C32	14P C14	14P C32	19F C14	19F C30	19J C14	19J C30	19P C14	19P C30	
GST06...	k	460		500		540		580								
GST07...	k	516		556		596		636		555		595		655		
GST09...	k	579		619		659		699		618		658		718		
GST11...	k	636		676		716		756		675		715		775		
GST14...	k									765		805		865		
...RSO B0 <sup>1)</sup>	Δ k	0														
...RSO P□ <sup>1)</sup>	Δ k	28						34			44					
	k <sub>1</sub>	201		241		281		321		220		260		320		
	k <sub>2</sub>	145						195								
	g	143						192								
...RSO	k <sub>5</sub>	24						15								
	g <sub>2</sub>	Ø 78														
	g <sub>1</sub>	116				147		116	147	141	172	141	172	141	172	
	n <sub>2</sub>	78				94		78	94	78	94	78	94	78	94	
	x	16				38		16	38	16	36	16	36	16	36	

1) → 801 - SRS/SRM/ECN/EQN/EQI/C20

GST□□-2S VCK

	o	o <sub>1</sub>	p	p <sub>1</sub>	a	d	l	l <sub>1</sub>	l <sub>2</sub>	d <sub>2</sub>	u	t
GST03...	90	127 <sup>2)</sup> 139 <sup>3)</sup>	100	64	2	14	28	4	20	M5	5	16
GST04...	100	174	129	77	0	20	40	5	28	M6	6	22.5
GST05...	115	214	156	98	1	25	50	4	40	M10	8	28
GST06...	145	243	194	121	2	30	60	6	45			33
GST07...	180	302	245	155	3	40	80	7	63	M16	12	43
GST09...	222	370	304	194	4	50	100	8	80		14	53.5
GST11...	270	433	378	243		60	120		100	M20	18	64
GST14...	328	533	470	306	6	80	160	15	125		22	85

	a <sub>2</sub>	b <sub>2</sub>	c <sub>2</sub>	e <sub>2</sub>	f <sub>2</sub>	i <sub>2</sub>	s <sub>2</sub>		a <sub>2</sub>	b <sub>2</sub>	c <sub>2</sub>	e <sub>2</sub>	f <sub>2</sub>	i <sub>2</sub>	s <sub>2</sub>
		j7					4x90°			j7					4x90°
GST03...	120	80	10	100	3	28 <sup>2)</sup> 40 <sup>3)</sup>	7	GST06...	160	110	12	130	3.5	60	9
	140	95		115			9		200	130		165			11
	160	110		130	3.5	250	180		15	215	80				
GST04...	120	80	10	100	3	40	7	GST07...	300	230	18	265	4	100	13.5
	140	95		115			9								
	160	110		130	3.5										
GST05...	120	80	12	100	3	50	7	GST11...	350	250	20	300	5	120	14
	140	95		115			9								
	160	110		130	3.5		GST14...	400	300	22	350	5	160	18	
	200	130		165											11

d ≤ 50 mm: k6; d > 50 mm: m6

<sup>2)</sup> d = 14

<sup>3)</sup> d = 20

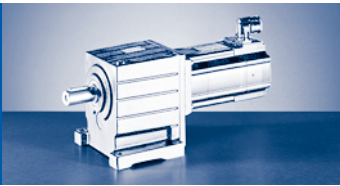

# GST [mm]

## GST□□-3S (MCS)

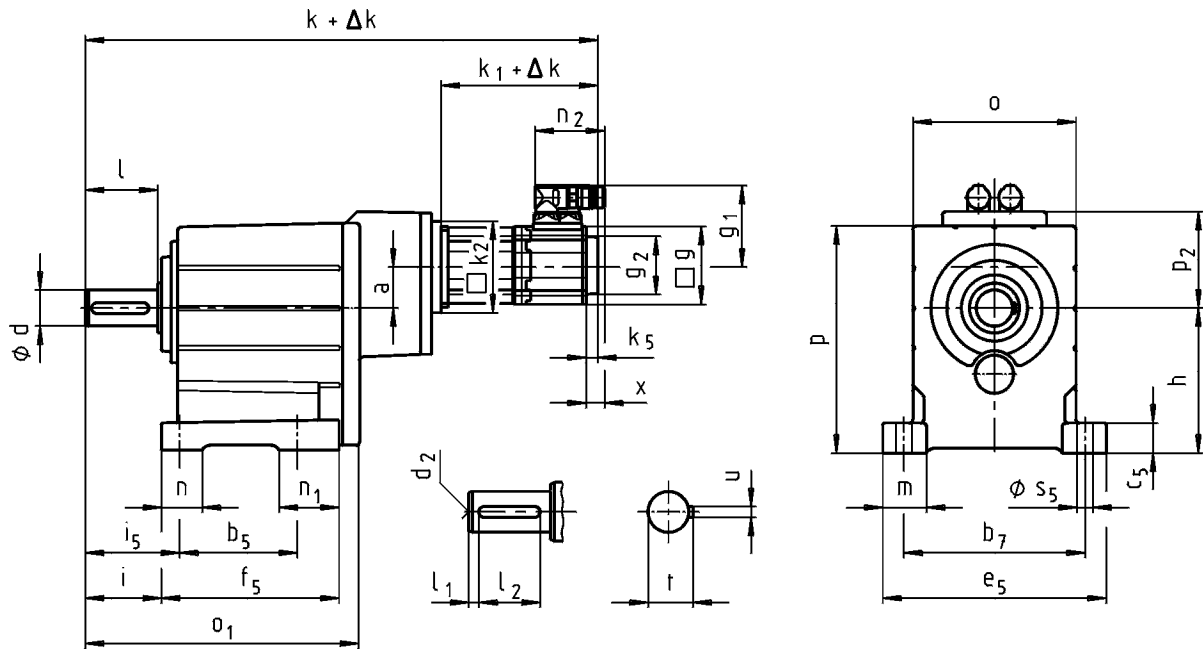

### GST□□-3S VBR ... RSO

		06C C41	06F C41	06I C41	09D C41	09F C38	09H C41	09L C41	12D C20	12D C41	12H C15	12H C30	12H C35	12L C20	12L C41	
GST05...	k	425	455	485	478	498	518	558								
GST06...	k	468	498	528	521	541	561	601								
GST07...	k	535	565	595	588	608	628	668	605		645			685		
GST09...	k	616	646	676	669	689	709	749	686		726			766		
GST11...	k				745	765	785	825	762		802			842		
GST14...	k								886		926			966		
...RSO B0 <sup>1)</sup>	Δ k	0														
...RSO P□ <sup>1)</sup>	Δ k	19				20										
...RSO	k <sub>1</sub>	132	162	192	183	203	223	263	188		228			268		
	k <sub>2</sub>	66			91				118				145 <sup>2)</sup>			
	g	62			89				116							
	k <sub>5</sub>	0			13				14							
	g <sub>2</sub>	□ 62			Ø 67				Ø 72							
	g <sub>1</sub>	76			90				105							
	n <sub>2</sub>	64							78							
	x				21				18							

<sup>1)</sup> → 801 - SRS/SRM/ECN/EQN/EQI/C20

<sup>2)</sup> GST07: 12DC20 ... 12LC41

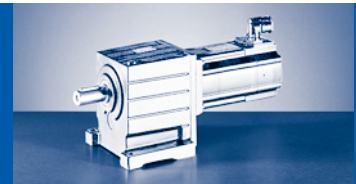

GST□□-3S VBR ... RSO

		14D C15	14D C36	14H C15	14H C32	14L C15	14L C32	14P C14	14P C32	19F C14	19F C30	19J C14	19J C30	19P C14	19P C30				
GST09...	k	701		741		781		821											
GST11...	k	777		817		857		897		816		856		916					
GST14...	k	901		941		981		1021		940		980		1040					
...RSO B0 <sup>1)</sup>	Δ k	0																	
...RSO P□ <sup>1)</sup>	Δ k	28						34			44								
	k <sub>1</sub>	201		241		281		321		220		260		320					
	k <sub>2</sub>	145						195											
	g	143						192											
...RSO	k <sub>5</sub>	24						15											
	g <sub>2</sub>	Ø 78																	
	g <sub>1</sub>	116				147		116		147		141		172		141		172	
	n <sub>2</sub>	78				94		78		94		78		94		78		94	
	x	16				38		16		38		16		36		16		36	

<sup>1)</sup> →  801 - SRS/SRM/ECN/EQN/EQI/C20

GST□□-3S VBR

	o	o <sub>1</sub>	p	p <sub>2</sub>	h	a
GST05...	115	208	159	87	100	35
GST06...	145	240	198		125	34
GST07...	180	302	251	103	160	42
GST09...	222	370	311	129	200	52
GST11...	270	433	385	162	250	66
GST14...	328	533	479	200	315	83

	d	l	l <sub>1</sub>	l <sub>2</sub>	d <sub>2</sub>	u	t	b <sub>5</sub>	b <sub>7</sub>	c <sub>5</sub>	e <sub>5</sub>	f <sub>5</sub>	i	i <sub>5</sub>	m	n	n <sub>1</sub>	s <sub>5</sub>
GST05...	25	50	4	40	M10	8	28	90	125	23	155	139	53	66	33	26	49	11
GST06...	30	60	6	45			33	106	160	28	196	157	64	79	38	35	52	13.5
GST07...	40	80	7	63	M16	12	43	130	200	34	247	196	84	104	49	45	66	18
GST09...	50	100	8	80			14	53.5	165	245	44	298	239	105	127.5	54	48	
GST11...	60	120		100	M20	18	64	200	300	54	368	280	125	155	69	65	80	22
GST14...	80	160	15	125			22	85	250	380	65	460	340	165	200	85	85	91

d ≤ 50 mm: k6; d > 50 mm: m6

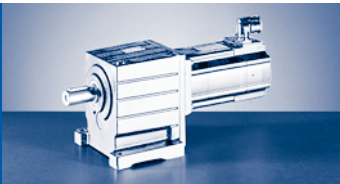

# GST [mm]

## GST□□-3S (MCS)

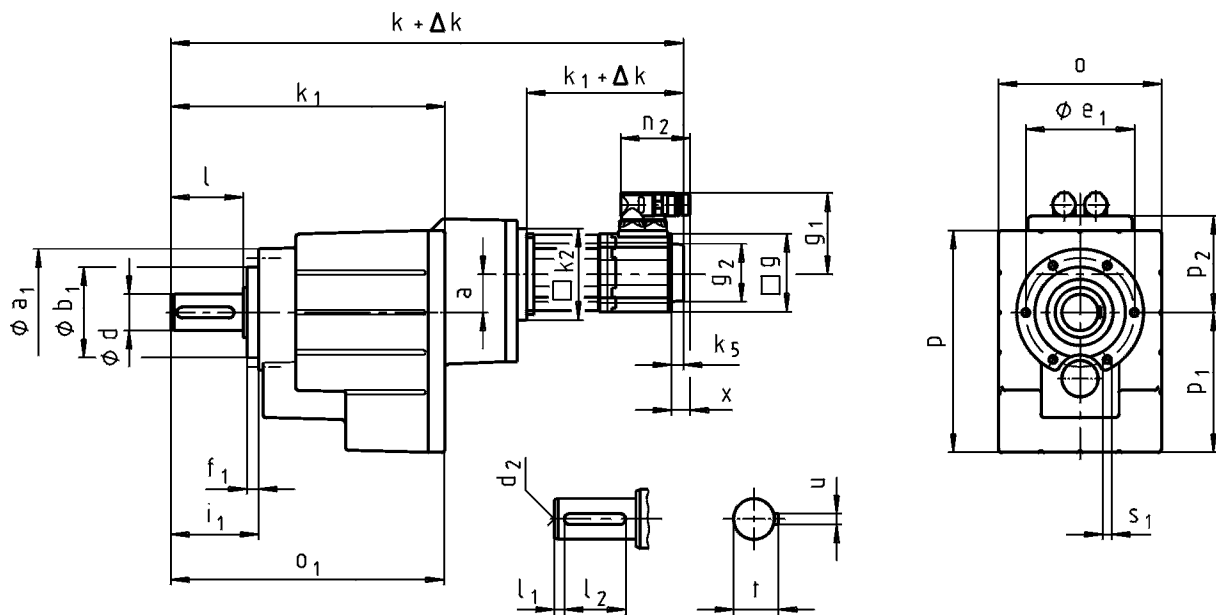

### GST□□-3S VCR ... RSO

		06C C41	06F C41	06I C41	09D C41	09F C38	09H C41	09L C41	12D C20	12D C41	12H C15	12H C30	12H C35	12L C20	12L C41	
GST05...	k	425	455	485	478	498	518	558								
GST06...	k	468	498	528	521	541	561	601								
GST07...	k	535	565	595	588	608	628	668	605		645			685		
GST09...	k	616	646	676	669	689	709	749	686		726			766		
GST11...	k				745	765	785	825	762		802			842		
GST14...	k								886		926			966		
...RSO B0 <sup>1)</sup>	$\Delta k$	0														
...RSO P□ <sup>2)</sup>	$\Delta k$	19				20										
	$k_1$	132	162	192	183	203	223	263	188		228			268		
	$k_2$	66			91								118	145 <sup>2)</sup>		
	g	62			89								116			
...RSO	$k_5$	0			13								14			
	$g_2$	□ 62			Ø 67								Ø 72			
	$g_1$	76			90								105			
	$n_2$	64							78							
	x					21								18		

<sup>1)</sup> → 801 - SRS/SRM/ECN/EQN/EQI/C20

<sup>2)</sup> GST07: 12DC20 ... 12LC41

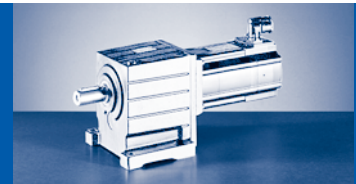

GST□□-3S VCR ... RSO

		14D C15	14D C36	14H C15	14H C32	14L C15	14L C32	14P C14	14P C32	19F C14	19F C30	19J C14	19J C30	19P C14	19P C30				
GST09...	k	701		741		781		821											
GST11...	k	777		817		857		897		816		856		916					
GST14...	k	901		941		981		1021		940		980		1040					
...RSO B0 <sup>1)</sup>	Δ k	0																	
...RSO P□ <sup>1)</sup>	Δ k	28						34			44								
	k <sub>1</sub>	201		241		281		321		220		260		320					
	k <sub>2</sub>	145						195											
	g	143						192											
...RSO	k <sub>5</sub>	24						15											
	g <sub>2</sub>	Ø 78																	
	g <sub>1</sub>	116				147		116		147		141		172		141		172	
	n <sub>2</sub>	78				94		78		94		78		94		78		94	
	x	16				38		16		38		16		36		16		36	

<sup>1)</sup> →  801 - SRS/SRM/ECN/EQN/EQI/C20

GST□□-3S VCR

	o	o <sub>1</sub>	p	p <sub>1</sub>	p <sub>2</sub>	a
GST05...	115	208	156	98	87	35
GST06...	145	240	194	121		34
GST07...	180	302	245	155	103	42
GST09...	222	370	304	194	129	52
GST11...	270	433	378	243	162	66
GST14...	328	533	470	306	200	83

	d	l	l <sub>1</sub>	l <sub>2</sub>	d <sub>2</sub>	u	t	a <sub>1</sub>	b <sub>1</sub>	e <sub>1</sub>	f <sub>1</sub>	i <sub>1</sub>	s <sub>1</sub>
									h7				6x60°
GST05...	25	50	4	40	M10	8	28	88	58	74	9	62	M6x12
GST06...	30	60	6	45			33	109	70	90	10	74	M8x14
GST07...	40	80	7	63	M16	12	43	140	100	120	13	97	M10x18
GST09...	50	100	8	80			53.5	174	120	145	15	120	M12x20
GST11...	60	120		100	M20	18	64	215	150	185	18	143	M16x26
GST14...	80	160	125	22			85	265	195	230	22	187	M20x34

d ≤ 50 mm: k6; d > 50 mm: m6

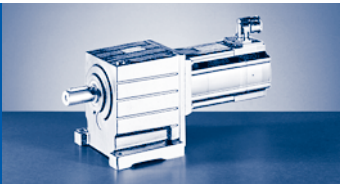

# GST [mm]

## GST□□-3S (MCS)

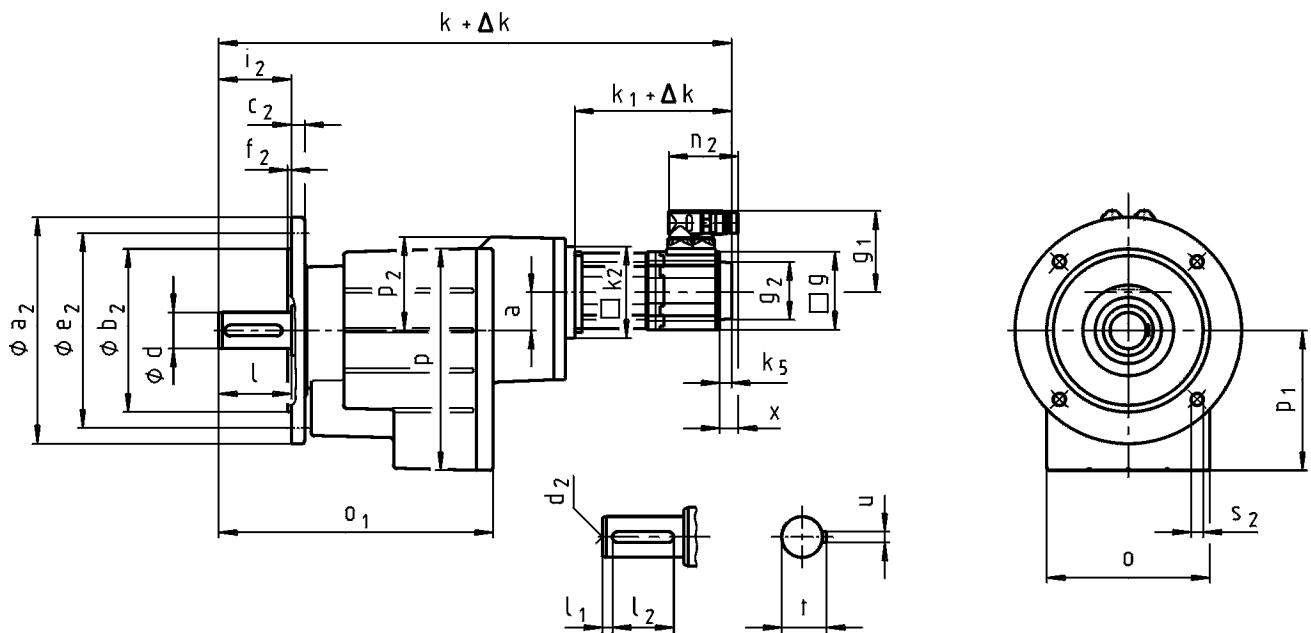

### GST□□-3S VCK ... RSO

		06C C41	06F C41	06I C41	09D C41	09F C38	09H C41	09L C41	12D C20	12D C41	12H C15	12H C30	12H C35	12L C20	12L C41	
GST05...	k	425	455	485	478	498	518	558								
GST06...	k	468	498	528	521	541	561	601								
GST07...	k	535	565	595	588	608	628	668	605			645			685	
GST09...	k	616	646	676	669	689	709	749	686			726			766	
GST11...	k				745	765	785	825	762			802			842	
GST14...	k								886			926			966	
...RSO B0 <sup>1)</sup>	Δ k	0														
...RSO P□ <sup>2)</sup>	Δ k	19				20										
	k <sub>1</sub>	132	162	192	183	203	223	263	188			228			268	
	k <sub>2</sub>	66			91							118			145 <sup>2)</sup>	
	g	62			89							116				
...RSO	k <sub>5</sub>	0			13							14				
	g <sub>2</sub>	□ 62			Ø 67							Ø 72				
	g <sub>1</sub>	76			90							105				
	n <sub>2</sub>	64								78						
	x					21							18			

<sup>1)</sup> → 801 - SRS/SRM/ECN/EQN/EQI/C20

<sup>2)</sup> GST07: 12DC20 ... 12LC41

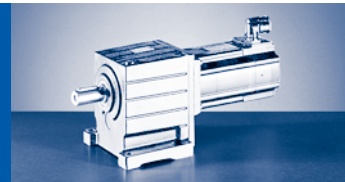

GST□□-3S VCK ... RSO

		14D C15	14D C36	14H C15	14H C32	14L C15	14L C32	14P C14	14P C32	19F C14	19F C30	19J C14	19J C30	19P C14	19P C30	
GST09...	k	701		741		781		821								
GST11...	k	777		817		857		897		816		856		916		
GST14...	k	901		941		981		1021		940		980		1040		
...RSO B0 <sup>1)</sup>	Δ k	0														
...RSO P□ <sup>1)</sup>	Δ k	28						34			44					
	k <sub>1</sub>	201		241		281		321		220		260		320		
	k <sub>2</sub>	145						195								
	g	143						192								
...RSO	k <sub>5</sub>	24						15								
	g <sub>2</sub>	Ø 78														
	g <sub>1</sub>	116				147		116	147	141	172	141	172	141	172	
	n <sub>2</sub>	78				94		78	94	78	94	78	94	78	94	
	x	16				38		16	38	16	36	16	36	16	36	

1) → 801 - SRS/SRM/ECN/EQN/EQI/C20

GST□□-3S VCK

	o	o <sub>1</sub>	p	p <sub>1</sub>	p <sub>2</sub>	a
GST05...	115	208	156	98	87	35
GST06...	145	240	194	121		34
GST07...	180	302	245	155	103	42
GST09...	222	370	304	194	129	52
GST11...	270	433	378	243	162	66
GST14...	328	533	470	306	200	83

	d	l	l <sub>1</sub>	l <sub>2</sub>	d <sub>2</sub>	u	t	a <sub>2</sub>	b <sub>2</sub>	c <sub>2</sub>	e <sub>2</sub>	f <sub>2</sub>	i <sub>2</sub>	s <sub>2</sub>
									j7					4x90°
GST05...	25	50	4	40	M10	8	28	120	80	10	100	3	50	7
								140	95		115			9
								160	110		130			11
								200	130		165			11
GST06...	30	60	6	45	M16	12	33	160	110	12	130	3.5	60	9
								200	130		165			11
GST07...	40	80	7	63	M16	14	43	250	180	15	215	4	80	13.5
								300	230		18			
GST09...	50	100	8	80	M20	18	53.5	350	250	20	300	5	100	14
								400	300		22			
GST11...	60	120	15	125	M20	22	85	400	300	24	350	5	120	18
								400	300		24			

d ≤ 50 mm: k6; d > 50 mm: m6

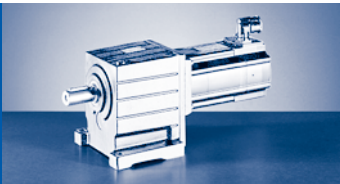

# GST [mm]

## GST□□-1A (MCA)

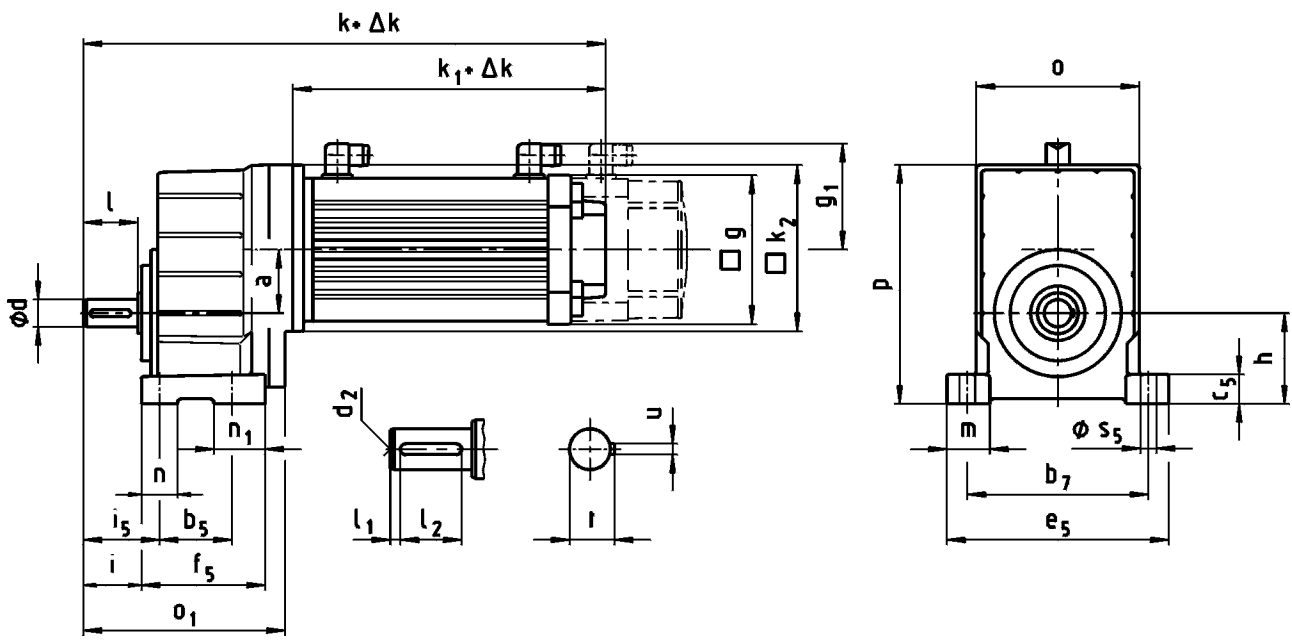

### GST□□-1A VBR ... RSO

		10I C40 ...S00	13I C41 ...S00	13I C34 ...F10	14L C20 ...S00	14L C41 ...S00	14L C16 ...F10	14L C35 ...F10	17N C23 ...S00	17N C41 ...S00
GST04...	k	407	415	483						
GST05...	k	428	436	504	486		548			
GST06...	k	451	459	527	509		571		548	
GST07...	k	480	488	556	538		600		577	
GST09...	k				581		643		620	
...RSO B0 <sup>1)</sup>	$\Delta k$	0								
...RSO P□ <sup>1)</sup>	$\Delta k$	25	35			33			35	
	$k_1$	258	267	335	307		369		346	
	$k_2$	145				180				
	g	102	131			142			165	
	$g_1$	90	102			109			118	

<sup>1)</sup> → 803 - SRS/SRM/ECN/EQN/EQI/S20/T20/CDD

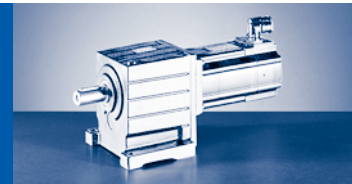

### GST□□-1A VBR ... RSO

		17N C17 ...F10	17N C35 ...F10	19S C23 ...S00	19S C42 ...S00	19S C17 ...F10	19S C35 ...F10	21X C25 ...S00	21X C42 ...S00	21X C17 ...F10	21X C35 ...F10
GST06...	k	637									
GST07...	k	666		646		743		724		820	
GST09...	k	709		689		786		767		863	
...RSO B0 <sup>1)</sup>	Δ k	0									
...RSO P□ <sup>1)</sup>	Δ k	35		38			42				
	k <sub>1</sub>	435		408		505		479		575	
	k <sub>2</sub>	180		222			265				
	g	165		192			214				
	g <sub>1</sub>	118		161			172				

<sup>1)</sup> → 803 - SRS/SRM/ECN/EQN/EQI/S20/T20/CDD

### GST□□-1A VBR

	o	o <sub>1</sub>	p	h	a
GST04...	100	134	138	50	36
GST05...	115	165	168	63	45
GST06...	145	191	211	80	56
GST07...	180	223	264	100	70
GST09...	222	271	329	125	89

	d	l	l <sub>1</sub>	l <sub>2</sub>	d <sub>2</sub>	u	t	b <sub>5</sub>	b <sub>7</sub>	c <sub>5</sub>	e <sub>5</sub>	f <sub>5</sub>	i	i <sub>5</sub>	m	n	n <sub>1</sub>	s <sub>5</sub>
GST04...	16	32	6	20	M5	5	18	55	105	17	128	80	35	45	24	20	25	9
GST05...	20	40		28	M6	6	22.5	70	125	22	154	99	43	56	32	26	29	11
GST06...	25	50	4	40	M10	8	28	72	160	27	194	115	53	68	37	30	43	13.5
GST07...	30	60	7.5	45			33	80	200	35	245	137	64	84	48	40	57	
GST09...	40	80	8.5	63			M16	12	43	105	245	43	296	161	84	107	51	

d ≤ 50 mm: k6; d > 50 mm: m6

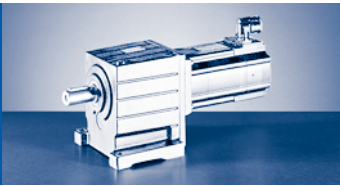

# GST [mm]

## GST□□-1A (MCA)

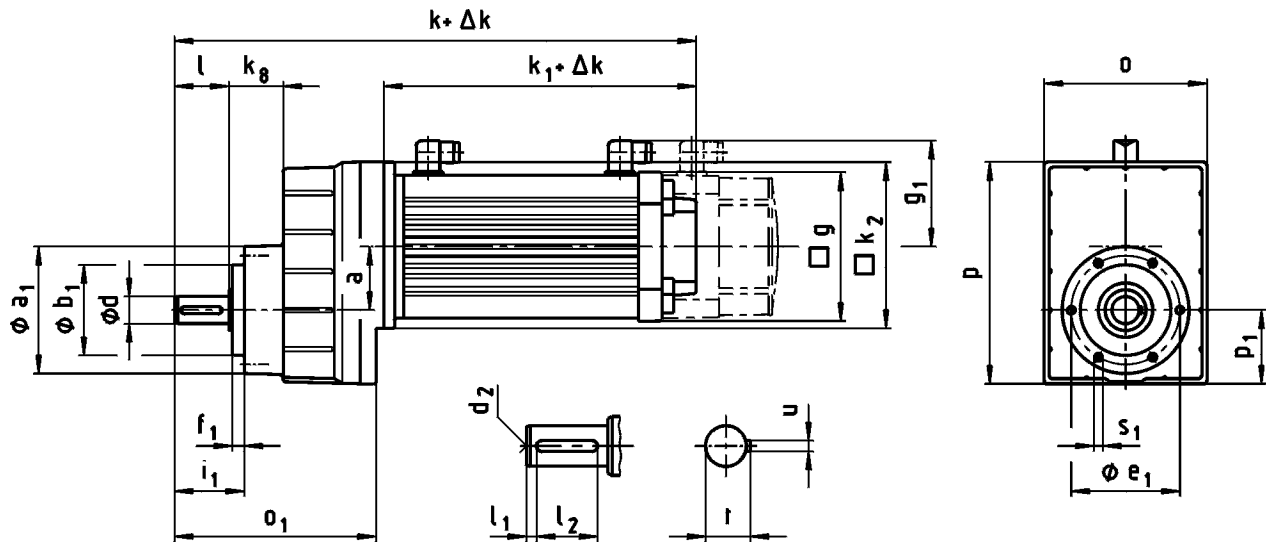

### GST□□-1A VCR ... RSO

		10I C40 ...S00	13I C41 ...S00	13I C34 ...F10	14L C20 ...S00	14L C41 ...S00	14L C16 ...F10	14L C35 ...F10	17N C23 ...S00	17N C41 ...S00
GST04...	k	407	415	483						
GST05...	k	428	436	504		486		548		
GST06...	k	451	459	527		509		571		548
GST07...	k	480	488	556		538		600		577
GST09...	k					581		643		620
...RSO B0 <sup>1)</sup>	$\Delta k$					0				
...RSO P□ <sup>1)</sup>	$\Delta k$	25	35			33				35
	$k_1$	258	267	335		307		369		346
	$k_2$		145					180		
	g	102	131			142				165
	g <sub>1</sub>	90	102			109				118

<sup>1)</sup> → 803 - SRS/SRM/ECN/EQN/EQI/S20/T20/CDD

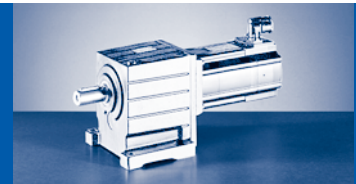

### GST□□-1A VCR ... RSO

		17N C17 ...F10	17N C35 ...F10	19S C23 ...S00	19S C42 ...S00	19S C17 ...F10	19S C35 ...F10	21X C25 ...S00	21X C42 ...S00	21X C17 ...F10	21X C35 ...F10
GST06...	k	637									
GST07...	k	666		646		743		724		820	
GST09...	k	709		689		786		767		863	
...RSO B0 <sup>1)</sup>	Δ k	0									
...RSO P□ <sup>1)</sup>	Δ k	35		38				42			
	k <sub>1</sub>	435		408		505		479		575	
	k <sub>2</sub>	180		222				265			
	g	165		192				214			
	g <sub>1</sub>	118		161				172			

<sup>1)</sup> → 803 - SRS/SRM/ECN/EQN/EQI/S20/T20/CDD

### GST□□-1A VCR

	o	o <sub>1</sub>	p	p <sub>1</sub>	a	k <sub>8</sub>
GST04...	100	134	129	41	36	35
GST05...	115	165	156	51	45	43
GST06...	145	191	194	63	56	48
GST07...	180	223	245	82	70	60
GST09...	222	271	304	101	89	74

	d	l	l <sub>1</sub>	l <sub>2</sub>	d <sub>2</sub>	u	t	a <sub>1</sub>	b <sub>1</sub>	e <sub>1</sub>	f <sub>1</sub>	i <sub>1</sub>	s <sub>1</sub>
									h7				6x60°
GST04...	16	32	6	20	M5	5	18	72	48	61	8	43	M5x10
GST05...	20	40		28	M6	6	22.5	88	58	74	9	52	M6x12
GST06...	25	50	4	40	M10	8	28	109	70	90	11	64	M8x14
GST07...	30	60	7.5	45			33	140	100	120	13	77	M10x18
GST09...	40	80	8.5	63	M16	12	43	174	120	145	15	100	M12x20

d ≤ 50 mm: k6; d > 50 mm: m6

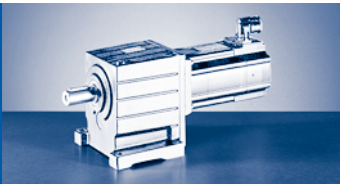

# GST [mm]

## GST□□-1A (MCA)

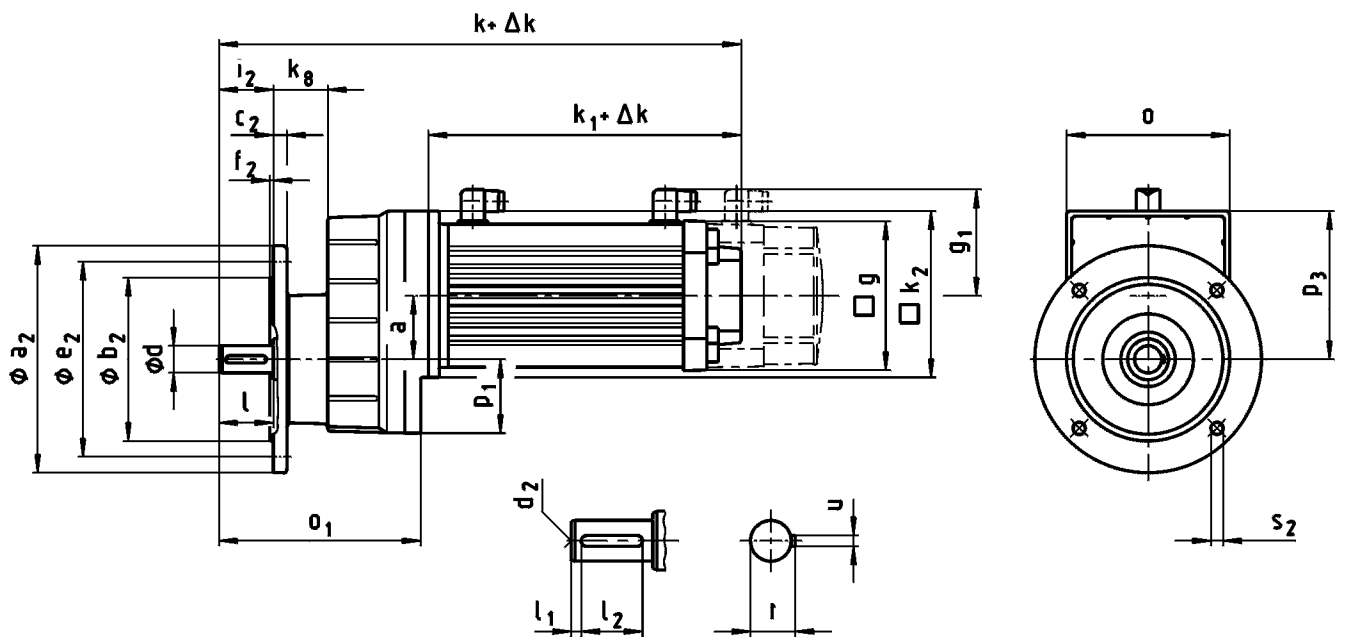

### GST□□-1A VCK ... RSO

		10I C40 ...S00	13I C41 ...S00	13I C34 ...F10	14L C20 ...S00	14L C41 ...S00	14L C16 ...F10	14L C35 ...F10	17N C23 ...S00	17N C41 ...S00
GST04...	k	407	415	483						
GST05...	k	428	436	504	486		548			
GST06...	k	451	459	527	509		571		548	
GST07...	k	480	488	556	538		600		577	
GST09...	k				581		643		620	
...RSO B0 <sup>1)</sup>	$\Delta k$	0								
...RSO P□ <sup>1)</sup>	$\Delta k$	25	35			33			35	
	$k_1$	258	267	335	307		369		346	
	$k_2$	145				180				
	g	102	131			142			165	
	$g_1$	90	102			109			118	

<sup>1)</sup> → 803 - SRS/SRM/ECN/EQN/EQI/S20/T20/CDD

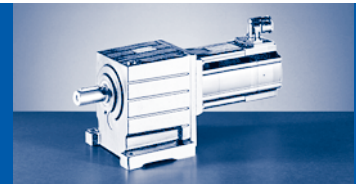

### GST□□-1A VCK ... RSO

		17N C17 ...F10	17N C35 ...F10	19S C23 ...S00	19S C42 ...S00	19S C17 ...F10	19S C35 ...F10	21X C25 ...S00	21X C42 ...S00	21X C17 ...F10	21X C35 ...F10
GST06...	k	637									
GST07...	k	666		646		743		724		820	
GST09...	k	709		689		786		767		863	
...RSO B0 <sup>1)</sup>	Δ k	0									
...RSO P□ <sup>1)</sup>	Δ k	35		38				42			
	k <sub>1</sub>	435		408		505		479		575	
	k <sub>2</sub>	180		222				265			
	g	165		192				214			
	g <sub>1</sub>	118		161				172			

<sup>1)</sup> → 803 - SRS/SRM/ECN/EQN/EQI/S20/T20/CDD

### GST□□-1A VCK

	o	o <sub>1</sub>	p <sub>1</sub>	p <sub>3</sub>	a	k <sub>8</sub>
GST04...	100	134	41	88	36	35
GST05...	115	165	51	105	45	43
GST06...	145	191	63	131	56	48
GST07...	180	223	82	164	70	60
GST09...	222	271	101	204	89	74

	d	l	l <sub>1</sub>	l <sub>2</sub>	d <sub>2</sub>	u	t	a <sub>2</sub>	b <sub>2</sub>	c <sub>2</sub>	e <sub>2</sub>	f <sub>2</sub>	i <sub>2</sub>	s <sub>2</sub>
									j7					4x90°
GST04...	16	32	6	20	M5	5	18	120	80	10	100	3	32	7
								140	95		115			9
								160	110		130			3.5
GST05...	20	40	6	28	M6	6	22.5	120	80	12	100	3	40	7
								140	95		115			9
								160	110		130			11
								200	130		165			11
GST06...	25	50	4	40	M10	8	28	160	110	14	130	3.5	50	9
								200	130		165			11
GST07...	30	60	7.5	45	M10	8	33	250	180	16	215	4	60	13.5
								300	230		18			265
GST09...	40	80	8.5	63	M16	12	43	250	180	16	215	4	80	13.5
								300	230		18			265

d ≤ 50 mm: k6; d > 50 mm: m6

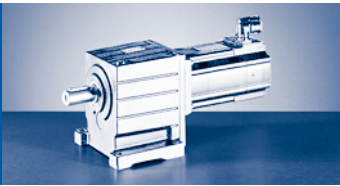

# GST [mm]

## GST□□-2A (MCA)

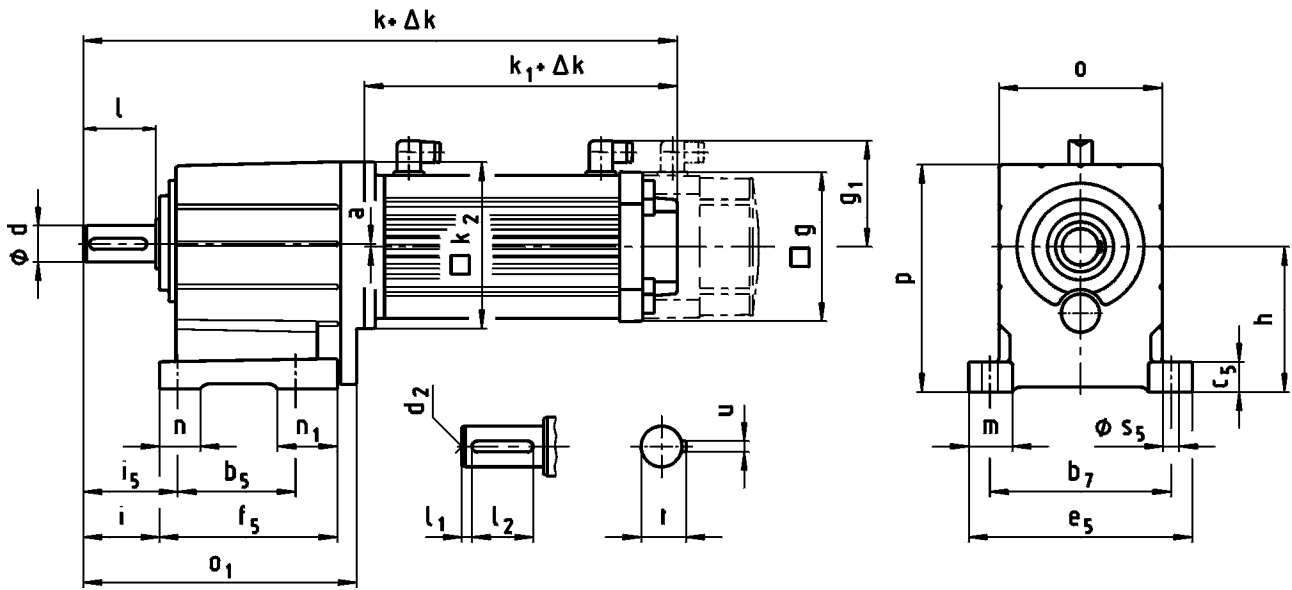

### GST□□-2A VBR ... RSO

		10I C40 ...S00	13I C41 ...S00	13I C34 ...F10	14L C20 ...S00	14L C41 ...S00	14L C16 ...F10	14L C35 ...F10	17N C23 ...S00	17N C41 ...S00
GST04...	k	447	455	523						
GST05...	k	477	485	553	535		597			
GST06...	k	503	511	579	561		623		600	
GST07...	k	559	567	635	617		679		656	
GST09...	k				680		742		719	
GST11...	k				737		799		776	
...RSO B0 <sup>1)</sup>	$\Delta k$					0				
...RSO P□ <sup>1)</sup>	$\Delta k$	25	35			33			35	
	$k_1$	258	267	335	307		369		346	
	$k_2$		145				180			
	g	102	131			142			165	
	$g_1$	90	102			109			118	

<sup>1)</sup> → 803 - SRS/SRM/ECN/EQN/EQI/S20/T20/CDD

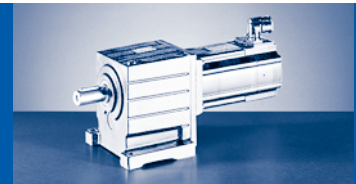

### GST□□-2A VBR ... RSO

		17N C17 ...F10	17N C35 ...F10	19S C23 ...S00	19S C42 ...S00	19S C17 ...F10	19S C35 ...F10	21X C25 ...S00	21X C42 ...S00	21X C17 ...F10	21X C35 ...F10
GST06...	k	689									
GST07...	k	745		725		822		803		899	
GST09...	k	808		788		885		866		962	
GST11...	k	865		845		942		923		1019	
GST14...	k			935		1032		1013		1109	
...RSO B0 <sup>1)</sup>	Δ k	0									
...RSO P□ <sup>1)</sup>	Δ k	35				38				42	
	k <sub>1</sub>	435		408		505		479		575	
	k <sub>2</sub>	180				222				265	
	g	165				192				214	
	g <sub>1</sub>	118				161				172	

<sup>1)</sup> → 803 - SRS/SRM/ECN/EQN/EQI/S20/T20/CDD

### GST□□-2A VBR

	o	o <sub>1</sub>	p	h	a
GST04...	100	174	132	80	0
GST05...	115	214	159	100	1
GST06...	145	243	198	125	2
GST07...	180	302	251	160	3
GST09...	222	370	311	200	4
GST11...	270	433	385	250	
GST14...	328	533	479	315	6

	d	l	l <sub>1</sub>	l <sub>2</sub>	d <sub>2</sub>	u	t	b <sub>5</sub>	b <sub>7</sub>	c <sub>5</sub>	e <sub>5</sub>	f <sub>5</sub>	i	i <sub>5</sub>	m	n	n <sub>1</sub>	s <sub>5</sub>
GST04...	20	40	5	28	M6	6	22.5	76	105	18	129	112	43	53	25	20	36	9
GST05...	25	50	4	40	M10	8	28	90	125	23	155	139	53	66	33	26	49	11
GST06...	30	60	6	45			33	106	160	28	196	157	164	79	38	35	52	13.5
GST07...	40	80	7	63	M16	12	43	130	200	34	247	196	84	104	49	45	66	18
GST09...	50	100	8	80			14	53.5	165	245	44	298	239	105	127.5	54	48	
GST11...	60	120		15	100	M20	18	64	200	300	54	368	280	125	155	69	65	80
GST14...	80	160	125		22			85	250	380	65	460	340	165	200	85	85	91

d ≤ 50 mm: k6; d > 50 mm: m6

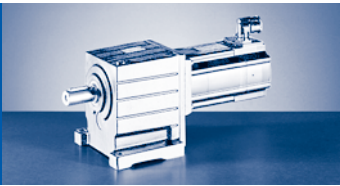

# GST [mm]

## GST□□-2A (MCA)

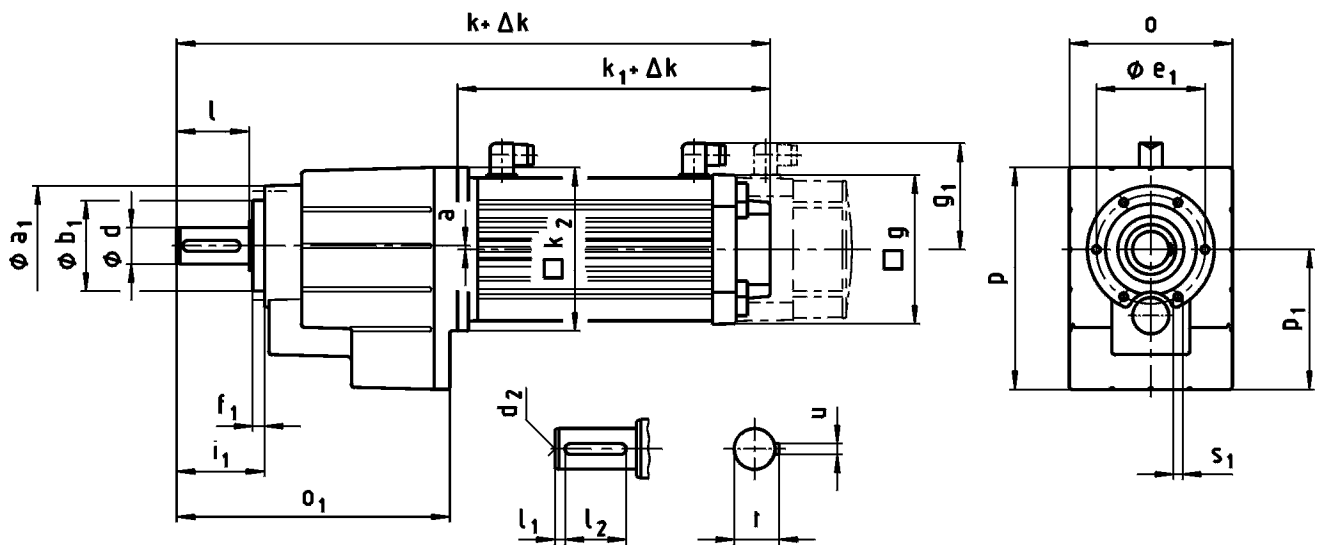

### GST□□-2A VCR ... RSO

		10I C40 ...S00	13I C41 ...S00	13I C34 ...F10	14L C20 ...S00	14L C41 ...S00	14L C16 ...F10	14L C35 ...F10	17N C23 ...S00	17N C41 ...S00
GST04...	k	447	455	523						
GST05...	k	477	485	553	535		597			
GST06...	k	503	511	579	561		623		600	
GST07...	k	559	567	635	617		679		656	
GST09...	k				680		742		719	
GST11...	k				737		799		776	
...RSO B0 <sup>1)</sup>	$\Delta k$					0				
...RSO P□ <sup>1)</sup>	$\Delta k$	25	35			33			35	
	$k_1$	258	267	335	307		369		346	
	$k_2$		145				180			
	g	102	131			142			165	
	$g_1$	90	102			109			118	

<sup>1)</sup> → 803 - SRS/SRM/ECN/EQN/EQI/S20/T20/CDD

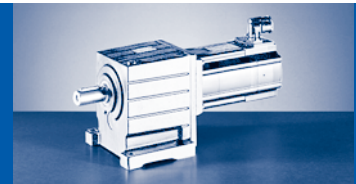

GST□□-2A VCR ... RSO

		17N C17 ...F10	17N C35 ...F10	19S C23 ...S00	19S C42 ...S00	19S C17 ...F10	19S C35 ...F10	21X C25 ...S00	21X C42 ...S00	21X C17 ...F10	21X C35 ...F10
GST06...	k	689									
GST07...	k	745		725		822		803		899	
GST09...	k	808		788		885		866		962	
GST11...	k	865		845		942		923		1019	
GST14...	k			935		1032		1013		1109	
...RSO B0 <sup>1)</sup>	Δ k	0									
...RSO P□ <sup>1)</sup>	Δ k	35		38				42			
	k <sub>1</sub>	435		408		505		479		575	
	k <sub>2</sub>	180		222				265			
	g	165		192				214			
	g <sub>1</sub>	118		161				172			

<sup>1)</sup> → 803 - SRS/SRM/ECN/EQN/EQI/S20/T20/CDD

GST□□-2A VCR

	o	o <sub>1</sub>	p	p <sub>1</sub>	a
GST04...	100	174	129	77	0
GST05...	115	214	156	98	1
GST06...	145	243	194	121	2
GST07...	180	302	245	155	3
GST09...	222	370	304	194	4
GST11...	270	433	378	243	
GST14...	328	533	470	306	6

	d	l	l <sub>1</sub>	l <sub>2</sub>	d <sub>2</sub>	u	t	a <sub>1</sub>	b <sub>1</sub>	e <sub>1</sub>	f <sub>1</sub>	i <sub>1</sub>	s <sub>1</sub>
									h7				6x60°
GST04...	20	40	5	28	M6	6	22.5	72	48	61	8	51	M5x10
GST05...	25	50	4	40	M10	8	28	88	58	74	9	62	M6x12
GST06...	30	60	6	45			33	109	70	90	10	74	M8x14
GST07...	40	80	7	63	M16	12	43	140	100	120	13	97	M10x18
GST09...	50	100	8	80		14	53.5	174	120	145	15	120	M12x20
GST11...	60	120		100	M20	18	64	215	150	185	18	143	M16x26
GST14...	80	160	15	125		22	85	265	195	230	22	187	M20x34

d ≤ 50 mm: k6; d > 50 mm: m6

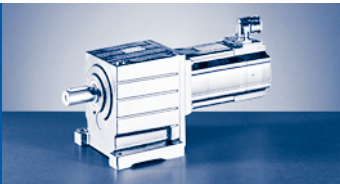

# GST [mm]

## GST□□-2A (MCA)

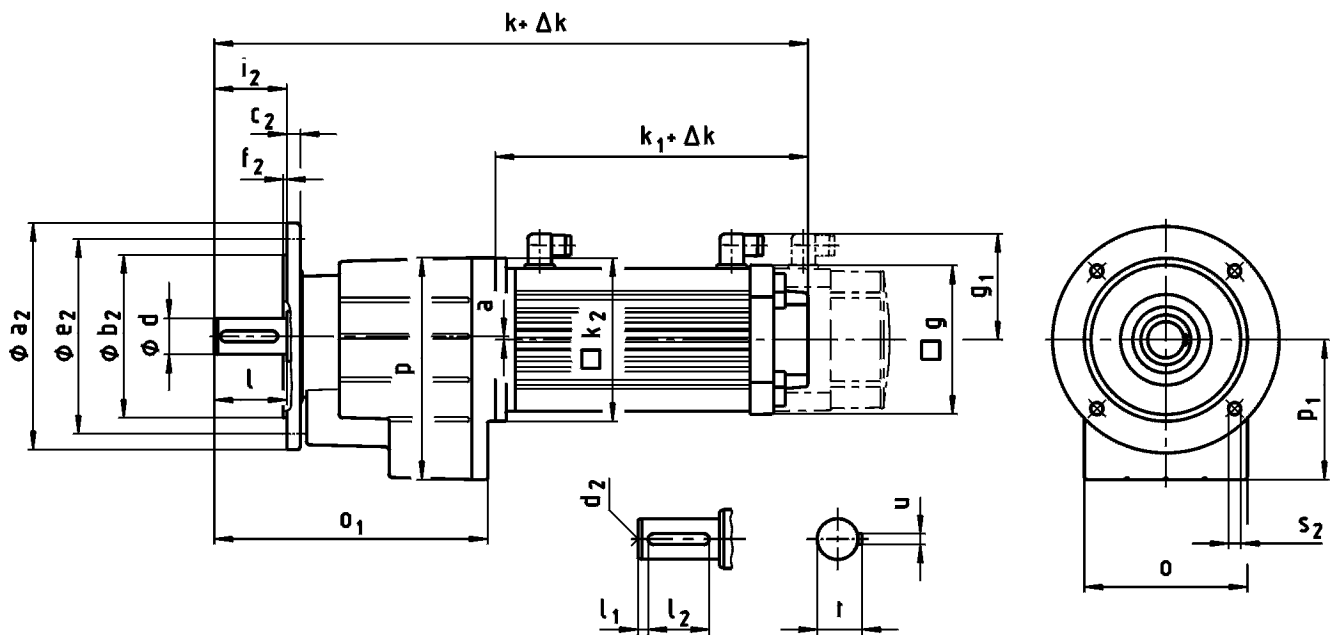

### GST□□-2A VCK ... RSO

		10I C40 ...S00	13I C41 ...S00	13I C34 ...F10	14L C20 ...S00	14L C41 ...S00	14L C16 ...F10	14L C35 ...F10	17N C23 ...S00	17N C41 ...S00
GST04...	k	447	455	523						
GST05...	k	477	485	553	535		597			
GST06...	k	503	511	579	561		623		600	
GST07...	k	559	567	635	617		679		656	
GST09...	k				680		742		719	
GST11...	k				737		799		776	
...RSO B0 <sup>1)</sup>	$\Delta k$	0								
...RSO P□ <sup>1)</sup>	$\Delta k$	25	35		33			35		
	$k_1$	258	267	335	307		369		346	
	$k_2$	145			180					
	g	102	131		142				165	
	$g_1$	90	102		109			118		

<sup>1)</sup> → 803 - SRS/SRM/ECN/EQN/EQI/S20/T20/CDD

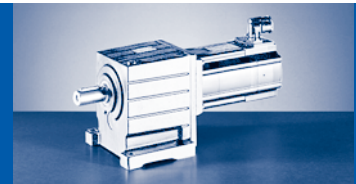

**GST□□-2A VCK ... RSO**

		17N C17 ...F10	17N C35 ...F10	19S C23 ...S00	19S C42 ...S00	19S C17 ...F10	19S C35 ...F10	21X C25 ...S00	21X C42 ...S00	21X C17 ...F10	21X C35 ...F10	
GST06...	k	689										
GST07...	k	745		725		822		803		899		
GST09...	k	808		788		885		866		962		
GST11...	k	865		845		942		923		1019		
GST14...	k			935		1032		1013		1109		
...RSO B0 <sup>1)</sup>	Δ k	0										
...RSO P□ <sup>1)</sup>	Δ k	35			38			42				
	k <sub>1</sub>	435		408		505		479		575		
	k <sub>2</sub>	180				222				265		
	g	165				192				214		
	g <sub>1</sub>	118				161				172		

<sup>1)</sup> → 803 - SRS/SRM/ECN/EQN/EQI/S20/T20/CDD

**GST□□-2A VCK**

	o	o <sub>1</sub>	p	p <sub>1</sub>	a	d	l	l <sub>1</sub>	l <sub>2</sub>	d <sub>2</sub>	u	t
GST04...	100	174	129	77	0	20	40	5	28	M6	6	22.5
GST05...	115	214	156	98	1	25	50	4	40	M10	8	28
GST06...	145	243	194	121	2	30	60	6	45			33
GST07...	180	302	245	155	3	40	80	7	63	M16	12	43
GST09...	222	370	304	194	4	50	100	8	80		14	53.5
GST11...	270	433	378	243		60	120		100	M20	18	64
GST14...	328	533	470	306	6	80	160	15	125		22	85

	a <sub>2</sub>	b <sub>2</sub>	c <sub>2</sub>	e <sub>2</sub>	f <sub>2</sub>	i <sub>2</sub>	s <sub>2</sub>		a <sub>2</sub>	b <sub>2</sub>	c <sub>2</sub>	e <sub>2</sub>	f <sub>2</sub>	i <sub>2</sub>	s <sub>2</sub>						
		j7					4x90°			j7					4x90°						
GST04...	120	80	10	100	3	40	7	GST07...	200	130	14	165	3.5	80	11						
	140	95		115			9		250	180	15	215			13.5						
	160	110		130	3.5		16			300	230		18			265	100				
GST05...	120	80	10	100	3	50	7	GST09...	300		230	18	265	4		120	14				
	140	95		115			9			350					250		20	300	18		
	160	110		130	3.5		11								400		300			22	350
GST06...	160	110	12	130	3.5	60	9	GST11...	350	250	20	300	5	120		18					
	200	130		165			11								400		300	22	350	5	160
	200	130		165			11										400	300	24	350	5

d ≤ 50 mm: k6; d > 50 mm: m6

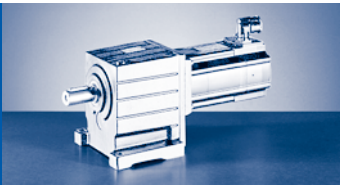

# GST [mm]

## GST□□-3A (MCA)

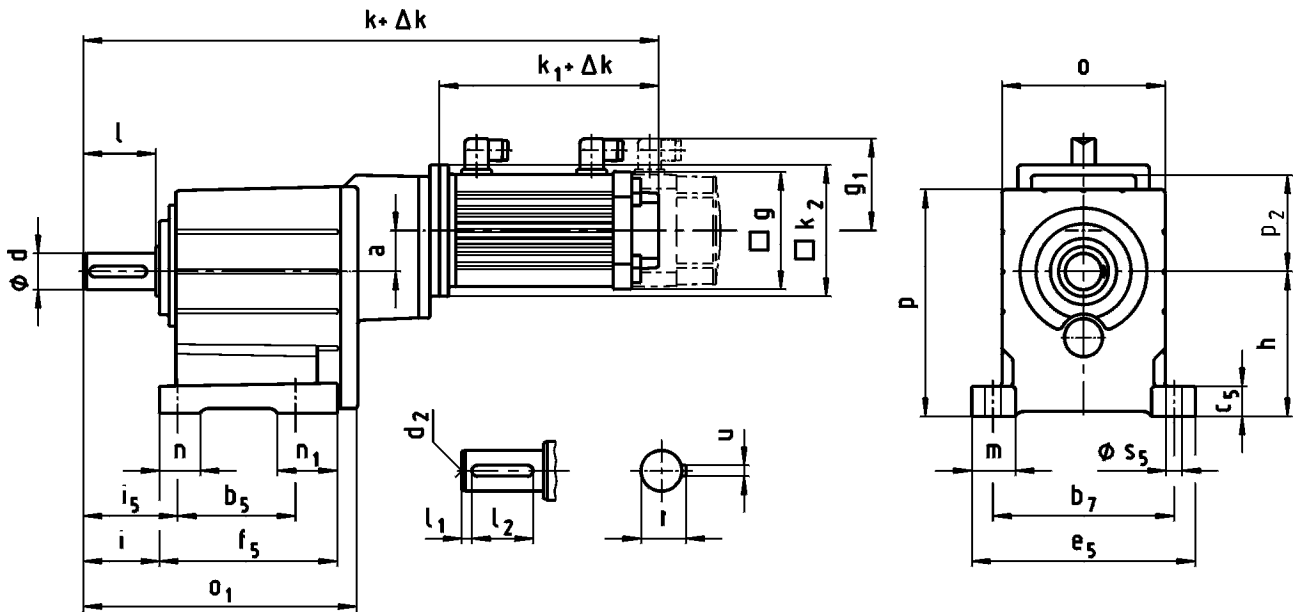

### GST□□-3A VBR ... RSO

		10I C40 ...S00	13I C41 ...S00	13I C34 ...F10	14L C20 ...S00	14L C41 ...S00	14L C16 ...F10	14L C35 ...F10	17N C23 ...S00	17N C41 ...S00
GST05...	k	553	562	630						
GST06...	k	596	605	673						
GST07...	k	663	672	740	722		784			
GST09...	k	744	753	821	803		865		842	
GST11...	k	820	829	897	879		941		918	
GST14...	k				1003		1065		1042	
...RSO B0 <sup>1)</sup>	$\Delta k$	0								
...RSO P□ <sup>1)</sup>	$\Delta k$	25	35			33			35	
	$k_1$	258	267	335	307		369		346	
	$k_2$	145				180				
	g	102	131			142			165	
	$g_1$	90	102			109			118	

<sup>1)</sup> → 803 - SRS/SRM/ECN/EQN/EQI/S20/T20/CDD

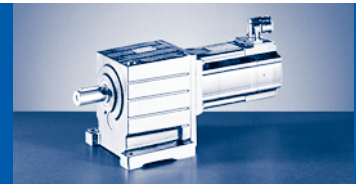

### GST□□-3A VBR ... RSO

		17N C17 ...F10	17N C35 ...F10	19S C23 ...S00	19S C42 ...S00	19S C17 ...F10	19S C35 ...F10	21X C25 ...S00	21X C42 ...S00	21X C17 ...F10	21X C35 ...F10
GST09...	k	931									
GST11...	k	1007		986		1083		1065		1161	
GST14...	k	1131		1110		1207		1189		1285	
...RSO B0 <sup>1)</sup>	Δ k	0									
...RSO P□ <sup>1)</sup>	Δ k	35		38				42			
	k <sub>1</sub>	435		408		505		479		575	
	k <sub>2</sub>	180		222				265			
	g	165		192				214			
	g <sub>1</sub>	118		161				172			

<sup>1)</sup> → 803 - SRS/SRM/ECN/EQN/EQI/S20/T20/CDD

### GST□□-3A VBR

	o		o <sub>1</sub>		p		p <sub>2</sub>		h		a	
GST05...	115		208		159		87		100		35	
GST06...	145		240		198				125		34	
GST07...	180		302		251		103		160		42	
GST09...	222		370		311		129		200		52	
GST11...	270		433		385		162		250		66	
GST14...	328		533		479		200		315		83	

	d	l	l <sub>1</sub>	l <sub>2</sub>	d <sub>2</sub>	u	t	b <sub>5</sub>	b <sub>7</sub>	c <sub>5</sub>	e <sub>5</sub>	f <sub>5</sub>	i	i <sub>5</sub>	m	n	n <sub>1</sub>	s <sub>5</sub>
GST05...	25	50	4	40	M10	8	28	90	125	23	155	139	53	66	33	26	49	11
GST06...	30	60	6	45			33	106	160	28	196	157	64	79	38	35	52	13.5
GST07...	40	80	7	63	M16	12	43	130	200	34	247	196	84	104	49	45	66	18
GST09...	50	100	8	80			14	53.5	165	245	44	298	239	105	127.5	54	48	
GST11...	60	120		100	M20	18	64	200	300	54	368	280	125	155	69	65	80	22
GST14...	80	160	15	125			22	85	250	380	65	460	340	165	200	85	85	91

d ≤ 50 mm: k6; d > 50 mm: m6



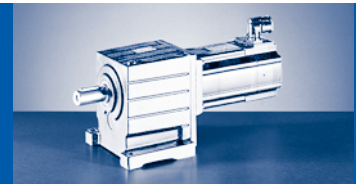

### GST□□-3A VCR ... RSO

		17N C17 ...F10	17N C35 ...F10	19S C23 ...S00	19S C42 ...S00	19S C17 ...F10	19S C35 ...F10	21X C25 ...S00	21X C42 ...S00	21X C17 ...F10	21X C35 ...F10
GST09...	k	931									
GST11...	k	1007		986		1083		1065		1161	
GST14...	k	1131		1110		1207		1189		1285	
...RSO B0 <sup>1)</sup>	Δ k	0									
...RSO P□ <sup>1)</sup>	Δ k	35		38				42			
	k <sub>1</sub>	435		408		505		479		575	
	k <sub>2</sub>	180		222				265			
	g	165		192				214			
	g <sub>1</sub>	118		161				172			

<sup>1)</sup> → 803 - SRS/SRM/ECN/EQN/EQI/S20/T20/CDD

### GST□□-3A VCR

	o	o <sub>1</sub>	p		p <sub>1</sub>		p <sub>2</sub>		a	
GST05...	115	208	156		98		87		35	
GST06...	145	240	194		121				34	
GST07...	180	302	245		155		103		42	
GST09...	222	370	304		194		129		52	
GST11...	270	433	378		243		162		66	
GST14...	328	533	470		306		200		83	

	d	l	l <sub>1</sub>	l <sub>2</sub>	d <sub>2</sub>	u	t	a <sub>1</sub>	b <sub>1</sub>	e <sub>1</sub>	f <sub>1</sub>	i <sub>1</sub>	s <sub>1</sub>
									h7				6x60°
GST05...	25	50	4	40	M10	8	28	88	58	74	9	62	M6x12
GST06...	30	60	6	45			33	109	70	90	10	74	M8x14
GST07...	40	80	7	63	M16	12	43	140	100	120	13	97	M10x18
GST09...	50	100	8	80			53.5	174	120	145	15	120	M12x20
GST11...	60	120		15	100	M20	18	64	215	150	185	18	143
GST14...	80	160	125		22		85	265	195	230	22	187	M20x34

d ≤ 50 mm: k6; d > 50 mm: m6

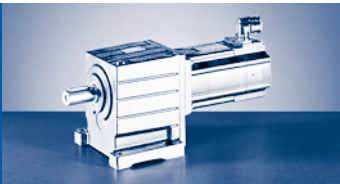

# GST [mm]

## GST□□-3A (MCA)

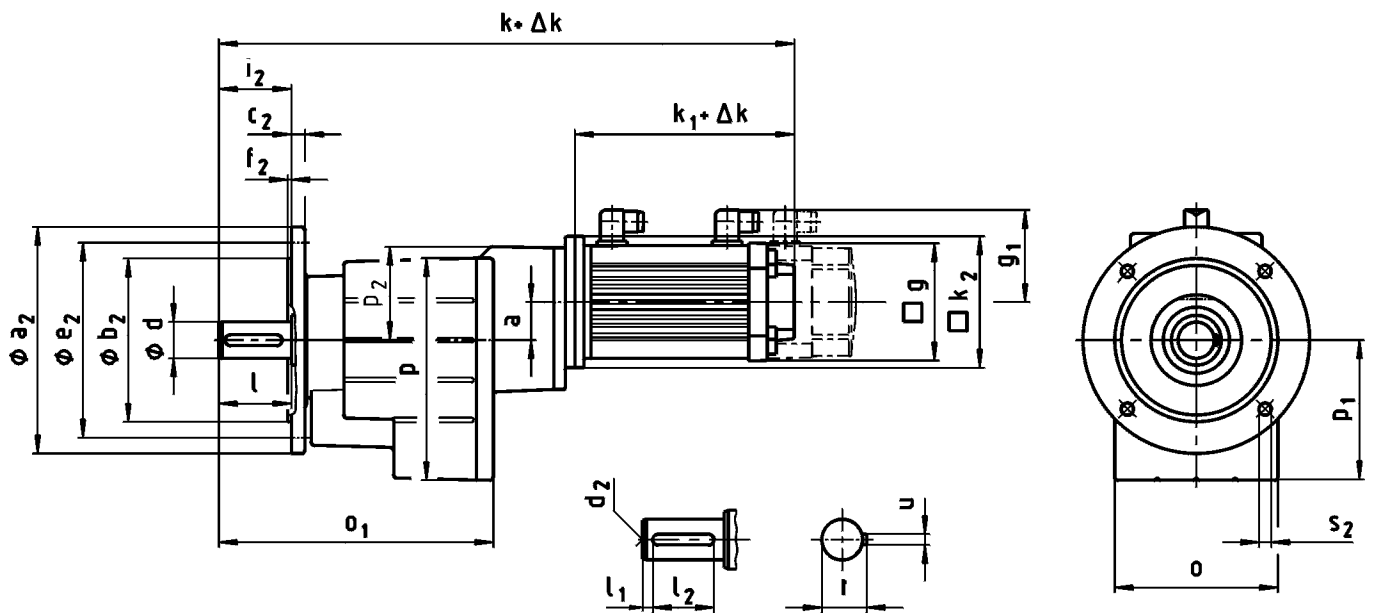

### GST□□-3A VCK ... RSO

		10I C40 ...S00	13I C41 ...S00	13I C34 ...F10	14L C20 ...S00	14L C41 ...S00	14L C16 ...F10	14L C35 ...F10	17N C23 ...S00	17N C41 ...S00
GST05...	k	553	562	630						
GST06...	k	596	605	673						
GST07...	k	663	672	740	722		784			
GST09...	k	744	753	821	803		865		842	
GST11...	k	820	829	897	879		941		918	
GST14...	k				1003		1065		1042	
...RSO B0 <sup>1)</sup>	$\Delta k$				0					
...RSO P□ <sup>1)</sup>	$\Delta k$	25	35			33			35	
	$k_1$	258	267	335	307		369		346	
	$k_2$		145				180			
	g	102	131			142			165	
	$g_1$	90	102			109			118	

<sup>1)</sup> → 803 - SRS/SRM/ECN/EQN/EQI/S20/T20/CDD

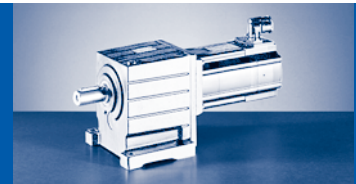

GST□□-3A VCK ... RSO

		17N C17 ...F10	17N C35 ...F10	19S C23 ...S00	19S C42 ...S00	19S C17 ...F10	19S C35 ...F10	21X C25 ...S00	21X C42 ...S00	21X C17 ...F10	21X C35 ...F10
GST09...	k	931									
GST11...	k	1007		986		1083		1065		1161	
GST14...	k	1131		1110		1207		1189		1285	
...RSO B0 <sup>1)</sup>	Δ k	0									
...RSO P□ <sup>1)</sup>	Δ k	35		38				42			
	k <sub>1</sub>	435		408		505		479		575	
	k <sub>2</sub>	180		222				265			
	g	165		192				214			
	g <sub>1</sub>	118		161				172			

<sup>1)</sup> → 803 - SRS/SRM/ECN/EQN/EQI/S20/T20/CDD

GST□□-3A VCK

	o	o <sub>1</sub>	p	p <sub>1</sub>	p <sub>2</sub>	a
GST05...	115	208	156	98	87	35
GST06...	145	240	194	121		34
GST07...	180	302	245	155	103	42
GST09...	222	370	304	194	129	52
GST11...	270	433	378	243	162	66
GST14...	328	533	470	306	200	83

	d	l	l <sub>1</sub>	l <sub>2</sub>	d <sub>2</sub>	u	t	a <sub>2</sub>	b <sub>2</sub>	c <sub>2</sub>	e <sub>2</sub>	f <sub>2</sub>	i <sub>2</sub>	s <sub>2</sub>
GST05...	25	50	4	40	M10	8	28	120	80	10	100	3	50	7
								140	95		115			9
								160	110	130	11			
								200	130	165	11			
GST06...	30	60	6	45	M16	12	33	160	110	12	130	3.5	60	9
								200	130	14	165			11
GST07...	40	80	7	63	M16	14	53.5	250	180	15	215	4	80	13.5
GST09...	50	100	8	80				16	265	100				
GST11...	60	120		100	M20	18	64	300	230	18	265	4	120	14
			350					250	20	300	18			
GST14...	80	160	15	125	M20	22	85	400	300	22	300	5	160	18
								400	300	24	350			18

d ≤ 50 mm: k6; d > 50 mm: m6

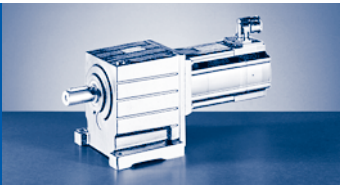

# GST & [mm]

GST□□-2 / 3

GST□□-2A/S VAR  
 GST□□-3A/S VAR

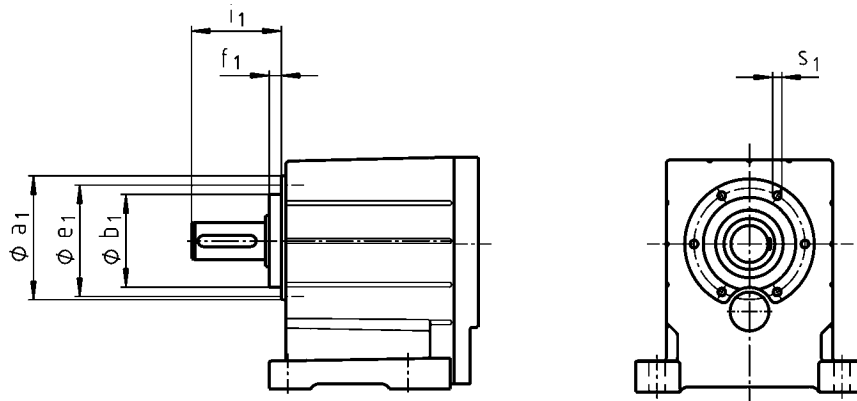

	$a_1$	$b_1$	$e_1$	$f_1$	$i_1$	$s_1$
		h7				6x60°
GST04...	72	48	61	8	51	M5x10
GST05...	88	58	74	9	62	M6x12
GST06...	109	70	90	10	74	M8x14
GST07...	140	100	120	13	97	M10x18
GST09...	174	120	145	15	120	M12x20
GST11...	215	150	185	18	143	M16x26
GST14...	265	195	230	22	187	M20x34

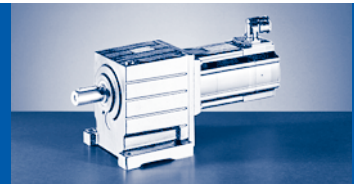

GST□□-2A/S VAL  
GST□□-3A/S VAL

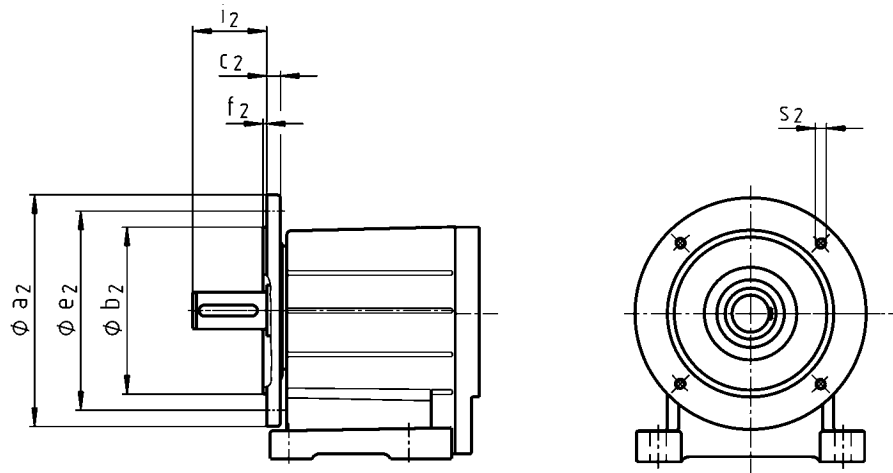

	$a_2$	$b_2$	$c_2$	$e_2$	$f_2$	$i_2$	$s_2$	
		j7					4x90°	
GST04...	120	80	10	100	3	40	M6	
	140	95		115			M8	
GST05...	120	80		100		50	M6	
	140	95		115	M8			
GST06...	160	110		12	130	3.5	60	M10
	200	130		14	165		80	
GST07...	250	180	15	215	4	100	M12	
			16					
GST09...	300	230	18	265		120	160	M16
	GST11...	350	250	20	300			
GST14...		400	300	22		350	5	
			24					

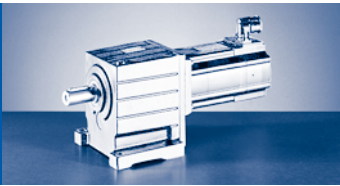

## GST & [mm]

GST□□-2 / 3