

Permissible radial force

$$Fr_{zul} = \min(f_w \times f_\alpha \times Fr_{Tab}; f_w \times Fr_{max})$$

Permissible axial force

$$Fa_{zul} = Fa_{Tab} \text{ at } Fr = 0$$

At Fr and $Fa \neq 0$ please contact your Lenze sales office.

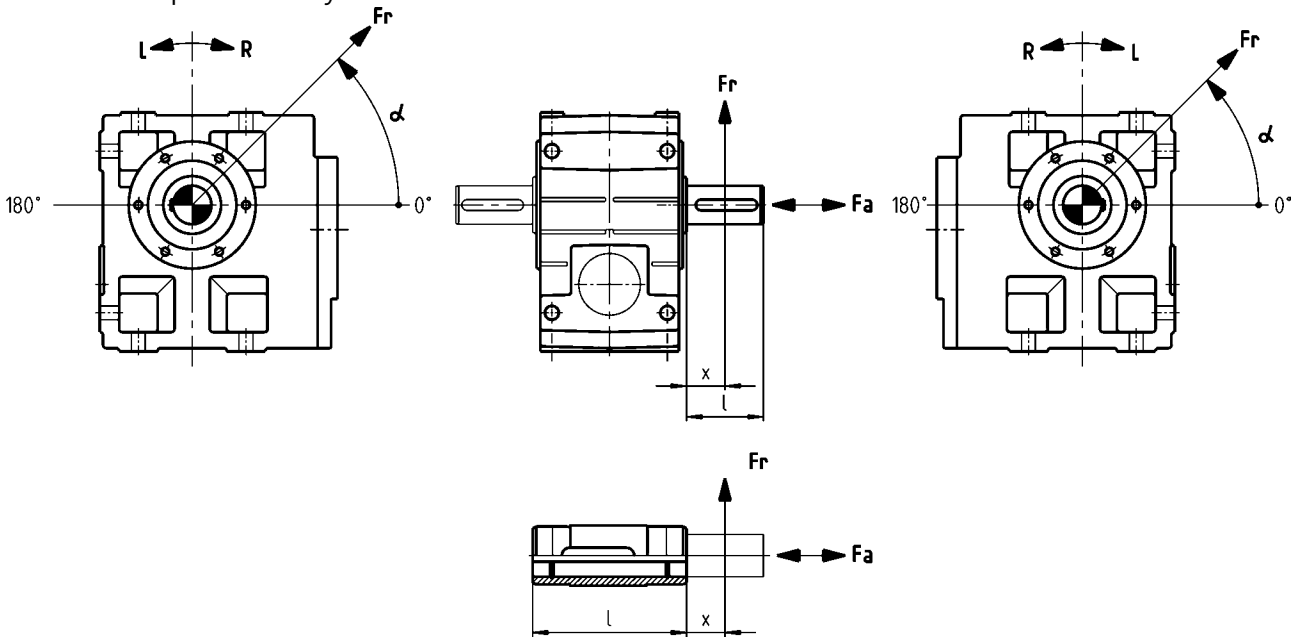

Effective direction factor f_α at output shaft

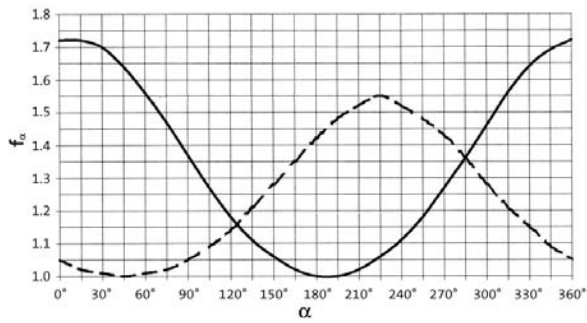

- Direction of rotation R
- - - Direction of rotation L

Additional load factor f_w at output shaft

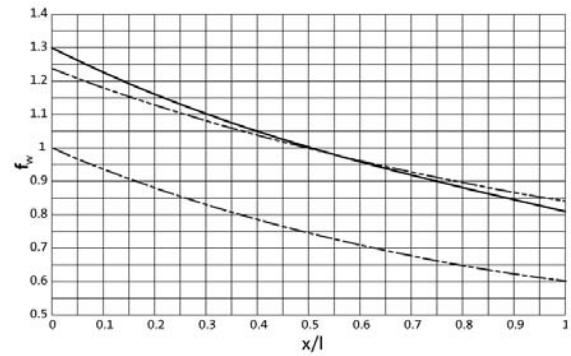

- Solid shaft (VQR)
- - - Solid shaft with flange (VQK)
- · - Hollow shaft (HQK)

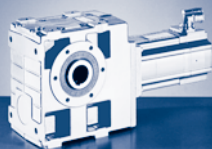

Solid shaft without flange (V□R) Application of force Fr: centre of shaft journal (x = l/2) Fa _{Tab} only valid for Fr = 0								
	GSS04-2		GSS05-2/3		GSS06-2/3		GSS07-2/3	
n ₂ [r/min]	Fr _{Tab} [N]	Fa _{Tab} [N]	Fr _{Tab} [N]	Fa _{Tab} [N]	Fr _{Tab} [N]	Fa _{Tab} [N]	Fr _{Tab} [N]	Fa _{Tab} [N]
630	2200	2200	2300	1600	3400	1900	3700	1800
400	2400	2900	2500	2200	3500	2500	4000	2400
250	3000	3700	2900	2800	3600	3200	4200	3100
160	3500	4200	3400	3500	4200	4100	5100	4100
100	4100	4900	4000	4400	5000	5200	6300	5500
63	4200	5500	4300	5500	5900	6500	7700	7200
40	4200	5500	4300	6000	6900	8200	9300	9500
25	4200	5500	4300	6000	8200	9000	11300	12500
≤ 16	4200	5500	4300	6000	8500	9000	12000	12500
Fr _{max}	4200	-	4300	-	8500	-	12000	-

Solid shaft with flange (V□K) Application of force Fr: centre of shaft journal (x = l/2) Fa _{Tab} only valid for Fr = 0								
	GSS04-2		GSS05-2/3		GSS06-2/3		GSS07-2/3	
n ₂ [r/min]	Fr _{Tab} [N]	Fa _{Tab} [N]	Fr _{Tab} [N]	Fa _{Tab} [N]	Fr _{Tab} [N]	Fa _{Tab} [N]	Fr _{Tab} [N]	Fa _{Tab} [N]
630	2750	2100	3450	1500	5100	1600	5500	1400
400	3000	2800	3750	2000	5250	2200	6000	1900
250	4100	3500	4900	2500	7000	2800	7900	2400
160	4400	4000	4900	3100	8100	3500	9100	3200
100	4700	4200	4900	4000	9400	4500	10600	4300
63	4700	4200	4900	4900	9400	5700	12400	5900
40	4700	4200	4900	5500	9400	7300	14000	8000
25	4700	4200	4900	5500	9400	8800	14000	10000
≤ 16	4700	4200	4900	5500	9400	8800	14000	10000
Fr _{max}	4700	-	4900	-	9400	-	14000	-

Hollow shaft (H□□) Application of force Fr: on hollow shaft end face (x = 0) Fa _{Tab} only valid for Fr = 0								
	GSS04-2		GSS05-2/3		GSS06-2/3		GSS07-2/3	
n ₂ [r/min]	Fr _{Tab} [N]	Fa _{Tab} [N]	Fr _{Tab} [N]	Fa _{Tab} [N]	Fr _{Tab} [N]	Fa _{Tab} [N]	Fr _{Tab} [N]	Fa _{Tab} [N]
630	2800	2200	3000	1600	4400	1900	4600	1800
400	3000	2900	3200	2200	4600	2500	5100	2400
250	3800	3700	3600	2800	4800	3200	5600	3100
160	4500	4200	4300	3500	5600	4100	6700	4100
100	5300	4900	5100	4400	6600	5200	8200	5500
63	6000	5500	6000	5500	7700	6500	10000	7200
40	6000	5500	7000	6000	9100	8200	12100	9500
25	6000	5500	7500	6000	10700	9000	14800	12500
≤ 16	6000	5500	7500	6000	11500	9000	16000	12500
Fr _{max}	6000	-	7500	-	11500	-	16000	-

- ▶ Neither radial nor axial forces are permissible for the hollow shaft with shrink disc (S□□).

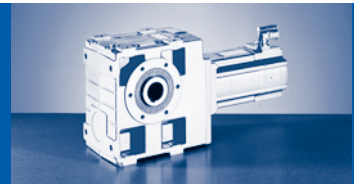

Position of ventilation, sealing elements and oil control

GSS05...07-2

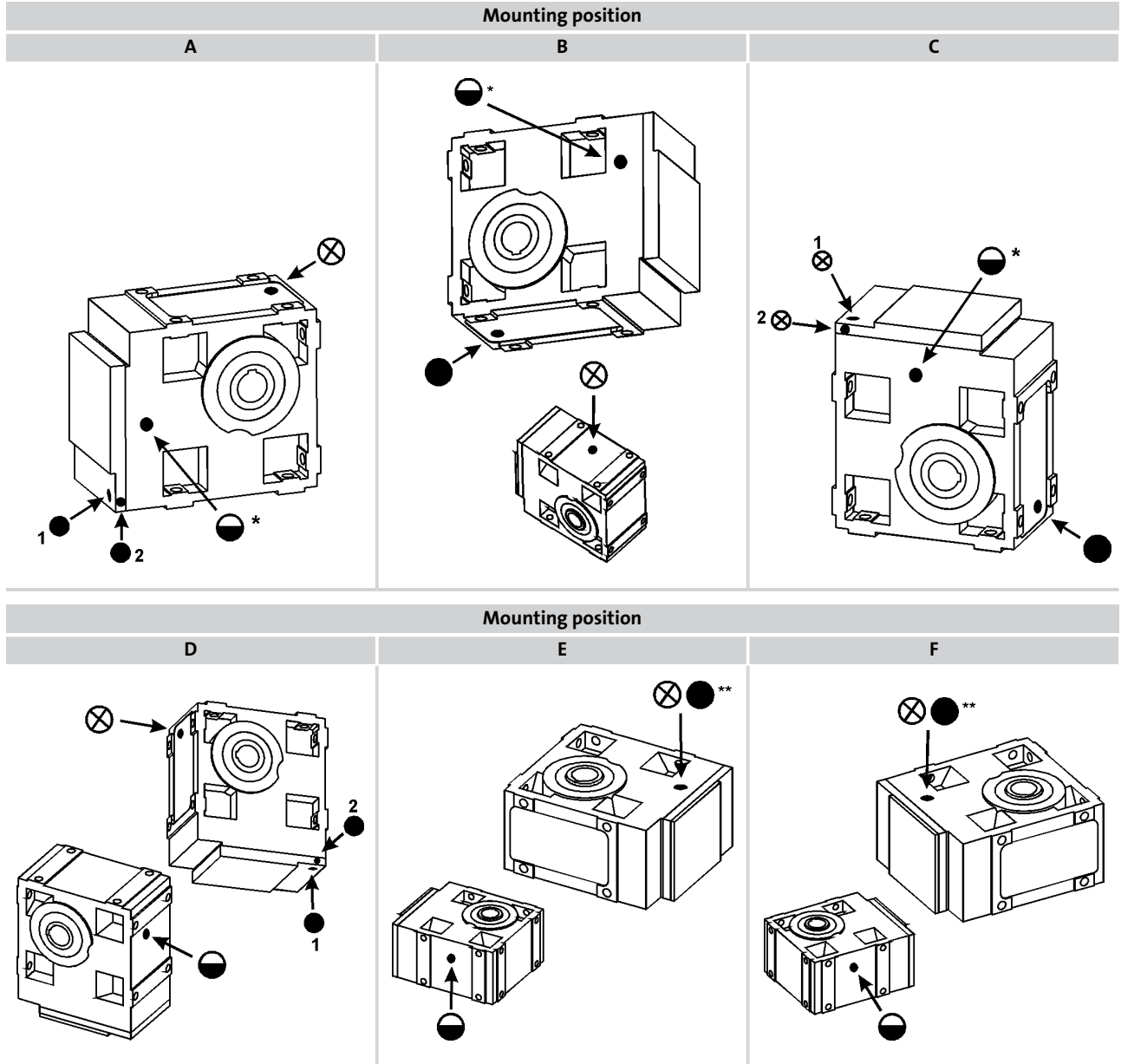

- ⊗ Ventilation/oil filler plug
- Oil drain plug
- ◐ Oil control plug
- * On both sides
- ** Opposite

Pos.1 standard
 Pos.2 only on GSS05-2A □□□ 14LC□□

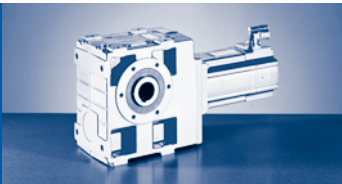

Position of ventilation, sealing elements and oil control

GSS05...07-3

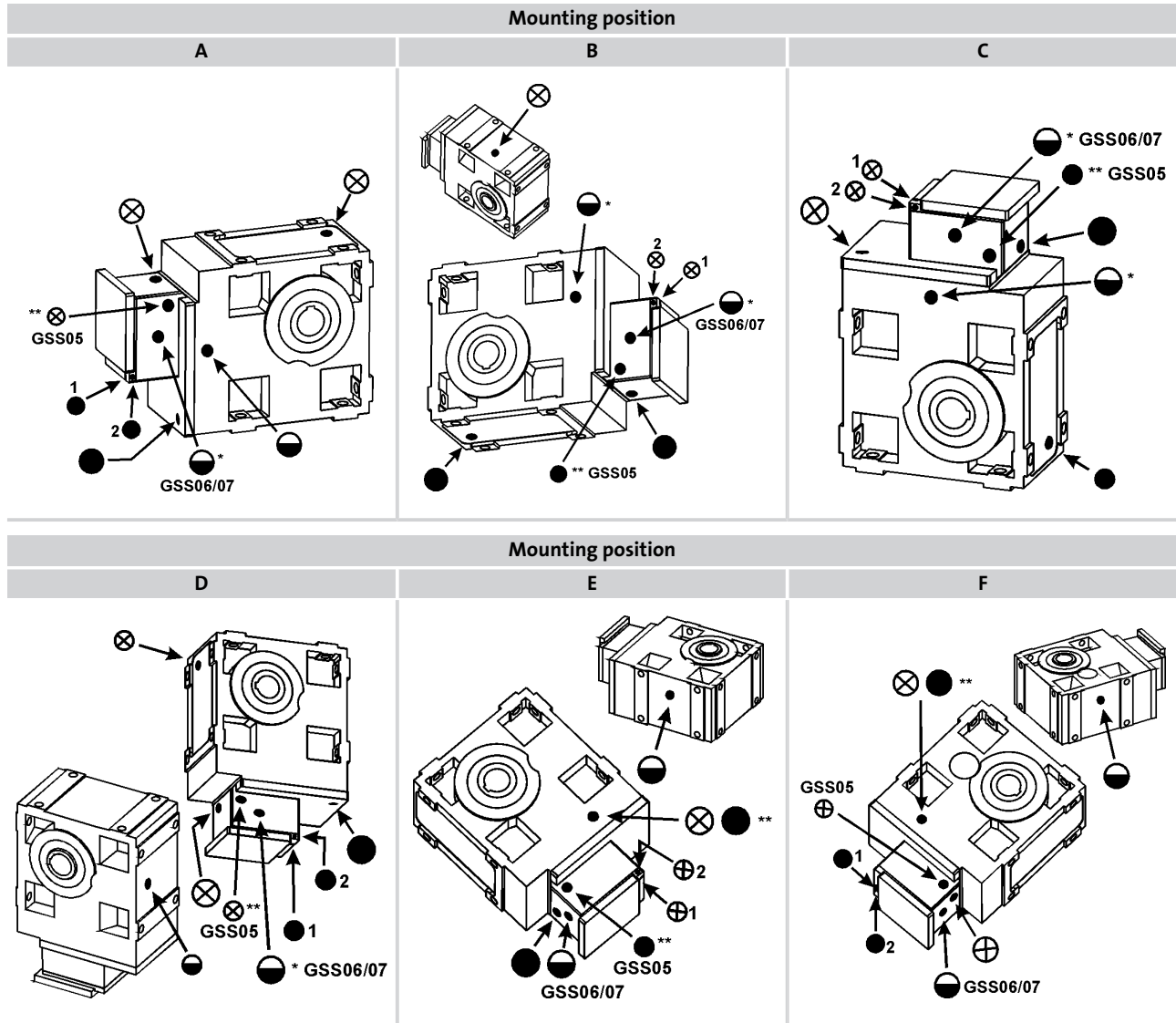

- ⊗ Ventilation/oil filler plug
- Oil drain plug
- Oil control plug
- * On both sides
- ** Opposite

Pos.1 standard
 Pos.2 only on GSS07-3A □□□ 14LC□□

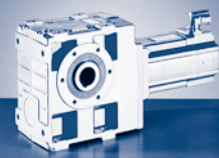

GSS□□-2S HAR/HBR...RSO B0

	06C C41	06F C41	06I C41	09D C41	09F C38	09H C41	09L C41	12D C20	12D C41	12H C15	12H C30	12H C35	12L C20	12L C41
GSS04...	14	15		17	18	19	21							
GSS05...	22	23		25	26	27	29	28			32			35
GSS06...	35	36		38	39	40	42	41			44			47
GSS07...				63	64	65	67	66			69			72
	14D C15	14D C36	14H C15	14H C32	14L C15	14L C32	14P C14	14P C32	19F C14	19F C30	19J C14	19J C30	19P C14	19P C30
GSS06...	46		51		55		60							
GSS07...	71		76		81		86		88		95			105

GSS□□-3S HAR/HBR...RSO B0

	06C C41	06F C41	06I C41	09D C41	09F C38	09H C41	09L C41	12D C20	12D C41	12H C15	12H C30	12H C35	12L C20	12L C41
GSS05...	25		26	28		29	31							
GSS06...	40		41	43	44		46							
GSS07...	67	68	69	70	71	72		74			77			80

Note additional weights.

Weights in [kg] with oil capacity for mounting position A, all given as approximate values

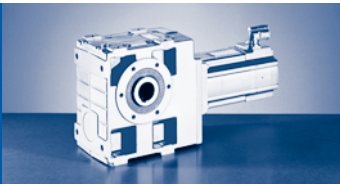

GSS [kg]

GSS□□-2A HAR/HBR...RSO B0

	10I C40 ...S00	13I C41 ...S00	13I C34 ...F10	14L C20 ...S00	14L C41 ...S00	14L C16 ...F10	14L C35 ...F10	17N C23 ...S00	17N C41 ...S00
GSS04...	18	23	24						
GSS05...	28	32	33	37		39			
GSS06...	40	44	45	50		52		58	
GSS07...	65	69	70	75		77		82	

	17N C17 ...F10	17N C35 ...F10	19S C23 ...S00	19S C42 ...S00	19S C17 ...F10	19S C35 ...F10	21X C25 ...S00	21X C42 ...S00	21X C17 ...F10	21X C35 ...F10
GSS06...	60									
GSS07...	85		106		109		123		126	

GSS□□-3A HAR/HBR...RSO B0

	10I C40 ...S00	13I C41 ...S00	13I C34 ...F10	14L C20 ...S00	14L C41 ...S00	14L C16 ...F10	14L C35 ...F10
GSS05...	28	33	35				
GSS06...	44	48	50				
GSS07...	73	77	78		82		84

Note additional weights.

Weights in [kg] with oil capacity for mounting position A, all given as approximate values

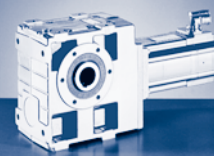

Additional weights MCS servo motors

	06C C41	06F C41	06I C41	09D C41	09F C38	09H C41	09L C41	12D C20	12D C41	12H C15	12H C30	12H C35	12L C20	12L C41
...P1	0.3			0.8				0.9						
...P2				0.5				1.2						
...SCS/SCM/SRM/SRS ...ECN/EQN	0.4			0.2				0.3						

	14D C15	14D C36	14H C15	14H C32	14L C15	14L C32	14P C14	14P C32	19F C14	19F C30	19J C14	19J C30	19P C14	19P C30
...P1	1.9						1.5							
...P2	3.1									4.3				
...SCS/SCM/SRM/SRS ...ECN/EQN							0.3							

Additional weights MCA servo motors

	10I C40 ...S00	13I C41 ...S00	13I C34 ...F10	14L C20 ...S00	14L C41 ...S00	14L C16 ...F10	14L C35 ...F10	17N C23 ...S00	17N C41 ...S00
...P1/P5								2.4	
...P2/P6	0.8	1.4		1.5					
...CDD ...ECN/EQN/EQI ...SCS/SCM/SRM/SRS/S20 ...T20	0.3	0.5		0.6				0.7	

	17N C17 ...F10	17N C35 ...F10	19S C23 ...S00	19S C42 ...S00	19S C17 ...F10	19S C35 ...F10	21X C25 ...S00	21X C42 ...S00	21X C17 ...F10	21X C35 ...F10
...P1/P5	2.4		4.8				5.0			
...P2/P6										
...CDD ...ECN/EQN/EQI ...SCS/SCM/SRM/SRS/S20 ...T20	0.7		1.0				1.1			

Additional weights gearbox

	Solid shaft	2nd output shaft end	Hollow shaft with shrink disc	Flange	Casing foot torque plate	Threaded hole circle torque plate
	V□□	V□□	S□□	□□K		
GSS04...	0.6	0.2	0.6	2.5	1.3	0.9
GSS05...	1	0.3	0.8	4	2.2	1.3
GSS06...	2.5	0.8	1	7	3.7	2.1
GSS07...	5	1.5	1.5	11	6.6	3.7

Weights in [kg]

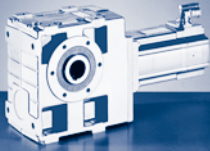

GSS [i]

► $i_g = z_g / z_t$

	i	z_g	z_t
GSS04-2	5.639	1015	180
	7.733	1160	150
	9.042	1085	120
	9.897	1247	126
	10.827	1624	150
	12.400	1240	100
	13.810	1740	126
	15.869	1333	84
	17.360	1736	100
	20.417	1225	60
	22.143	1860	84
	24.800	1240	50
	27.125	1953	72
	31.738	1333	42
	34.100	2046	60
	39.200	1960	50
	43.917	2108	48
	50.000	2100	42
	54.250	1953	36
	61.250	2205	30
	68.200	2046	30
	77.000	2310	24
	87.833	2108	24
	99.167	2380	22
111.318	2449	22	
125.682	2765	18	
139.500	2511	18	
157.500	2835	14	
183.786	2573	14	
207.500	2905	14	
GSS05-2	5.639	1015	180
	7.733	1160	150
	9.042	1085	120
	9.897	1247	126
	10.827	1624	150
	12.400	1240	100
	13.810	1740	126
	15.869	1333	84
	17.360	1736	100
	20.417	1225	60
	22.143	1860	84
	24.800	1240	50
	27.125	1953	72
	31.738	1333	42
	35.306	2542	72
	39.200	1960	50

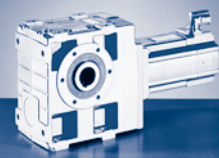

► $i_g = z_g / z_t$

	i	z_g	z_t
GSS05-2	43.917	2108	48
	50.000	2100	42
	54.250	1953	
	61.250	2205	36
	70.611	2542	
	79.722	2870	
	87.833	2108	
	99.167	2380	24
	113.667	2728	
	128.333	3080	
	137.950	2759	20
	155.750	3115	
	176.313	2821	16
	199.063	3185	
GSS05-3	125.476	126480	1008
	153.708	132804	864
	193.233	139128	720
	222.133	133280	600
	250.952	126480	
	283.333	142800	504
	307.417	132804	
	347.083	149940	432
	386.467	139128	
	436.333	157080	360
	497.722	143344	
	561.944	161840	288
	630.803	166532	
	712.197	188020	264
	790.500	170748	
	892.500	192780	216
	1041.452	174964	
	1175.833	197540	168
GSS06-2	5.833	1050	180
	8.000	1200	150
	9.042	1085	120
	10.238	1290	126
	11.200	1680	150
	12.400	1240	100
	14.286	1800	126
	15.869	1333	84
	17.360	1736	100
	20.417	1225	60
	22.143	1860	84
	24.800	1240	50
	27.125	1953	72
	31.738	1333	42

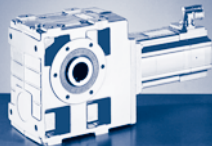

GSS [i]

► $i_g = z_g / z_t$

	i	z_g	z_t
GSS06-2	35.306	2542	72
	39.200	1960	50
	43.917	2108	48
	50.000	2100	42
	54.250	1953	
	61.250	2205	
	70.611	2542	36
	79.722	2870	
	87.833	2108	
	99.167	2380	
	113.667	2728	24
	128.333	3080	
	137.950	2759	
	155.750	3115	20
	174.375	2790	
	196.875	3150	16
	GSS06-3	126.531	111600
142.857		126000	882
155.000		117180	
175.000		132300	756
194.857		122760	
220.000		138600	630
238.700		128898	
269.500		145530	
310.689		167772	540
350.778		189420	
386.467		139128	
436.333		157080	360
497.722		143344	
561.944		161840	288
630.803		166532	
712.197		188020	
816.333		215512	264
921.667		243320	
1023.000		220968	
1155.000		249480	216
1241.550	223479		
1401.750	252315	180	
1635.693	228997		
1846.750	258545	140	
GSS07-2	5.862	1020	174
	8.125	1170	144
	9.086	1054	116
	10.000	1260	126
	11.200	1680	150
	12.594	1209	96
	14.286	1800	126

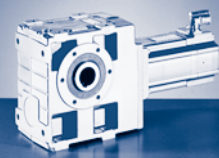

► $i_g = z_g / z_t$

	i	z_g	z_t
GSS07-2	15.500	1302	84
	17.360	1736	100
	20.517	1190	58
	22.143	1860	84
	25.188	1209	48
	27.125	1953	72
	31.000	1302	42
	35.306	2542	72
	39.200	1960	50
	43.271	2077	48
	50.000	2100	42
	54.250	1953	
	61.250	2205	36
	70.611	2542	
	79.722	2870	
	86.542	2077	
	97.708	2345	
	113.667	2728	24
	128.333	3080	
	137.950	2759	
155.750	3115	20	
174.375	2790		
196.875	3150	16	
GSS07-3	126.531	111600	882
	142.857	126000	
	155.000	117180	
	175.000	132300	
	201.746	152520	756
	227.778	172200	
	247.139	160146	
	279.028	180810	
	321.673	208444	648
	363.179	235340	
	394.245	170314	
	445.116	192290	432
	490.403	141236	
	553.681	159460	
	634.639	182776	
	716.528	206360	288
	833.556	240064	
	941.111	271040	
	1011.633	242792	
	1142.167	274120	240
1227.755	245551		
1386.175	277235	200	
1569.181	251069		
1771.656	283465	160	

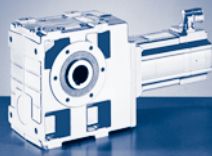

GSS [Nm]

GSS□□-□S (MCS)

$M_{2GN} \leq 180 \text{ Nm}$

GSS04-2S				06CC41	06FC41	06IC41	09DC41	09FC38	09HC41	09LC41
				...500	...500	...500	...500	...500	...500	...500
i	M_{2GN}	J_G	M_1	0.60	1.20	1.50	2.30	3.10	3.80	4.50
			n_1	4050	4050	4050	4050	3750	4050	4050
			I_{M230}	2.6	2.9	3.2	4.6	5.0	6.8	8.4
			I_{M400}	1.3	1.5	1.6	2.3	2.5	3.4	4.2
			P_N	0.25	0.51	0.64	1.00	1.20	1.60	1.90
			J_M	0.17	0.25	0.33	1.13	1.53	1.93	2.83
5.639	86	1.12	M_2			7				
			c			5.8				
			$n_{2 \text{ Eck}}$			718				
			$n_{2 \text{ th}}$			718				
5.639	144	1.12	M_2				11	15	19	22
			c				3.8	2.8	2.3	2.0
			$n_{2 \text{ Eck}}$				718	665	718	718
			$n_{2 \text{ th}}$				718	665	718	718
7.733	158	0.65	M_2				15	21	26	31
			c				4.7	3.5	2.8	2.4
			$n_{2 \text{ Eck}}$				524	485	524	524
			$n_{2 \text{ th}}$				524	485	524	524
9.042	154	0.81	M_2				18	24	30	35
			c				5.3	3.9	3.2	2.7
			$n_{2 \text{ Eck}}$				448	415	448	448
			$n_{2 \text{ th}}$				448	415	448	448
9.897	161	0.43	M_2				20	27	33	39
			c				5.0	3.7	3.0	2.5
			$n_{2 \text{ Eck}}$				409	379	409	409
			$n_{2 \text{ th}}$				409	379	409	409
10.827	161	0.37	M_2				21	29	36	43
			c				5.0	3.7	3.0	2.6
			$n_{2 \text{ Eck}}$				374	346	374	374
			$n_{2 \text{ th}}$				374	346	374	374
12.400	170	0.49	M_2				24	33	41	49
			c				4.8	3.5	2.9	2.4
			$n_{2 \text{ Eck}}$				327	302	327	327
			$n_{2 \text{ th}}$				327	302	327	327
13.810	163	0.25	M_2				27	38	46	55
			c				5.0	3.7	3.0	2.6
			$n_{2 \text{ Eck}}$				293	272	293	293
			$n_{2 \text{ th}}$				293	272	293	293
15.869	180	0.33	M_2				31	43	53	63
			c				4.1	3.0	2.5	2.1
			$n_{2 \text{ Eck}}$				255	236	255	255
			$n_{2 \text{ th}}$				255	236	255	255
17.360	180	0.28	M_2			22	34	47	58	69
			c			5.9	3.8	2.9	2.3	2.0
			$n_{2 \text{ Eck}}$			233	233	216	233	233
			$n_{2 \text{ th}}$			233	233	216	233	233
20.417	153	0.67	M_2		19	24	37	50	62	73
			c		5.4	4.3	2.8	2.1	1.7	1.4
			$n_{2 \text{ Eck}}$		198	198	198	184	198	198
			$n_{2 \text{ th}}$		198	198	198	184	198	198
22.143	180	0.20	M_2			28	44	60	74	87
			c			5.0	3.3	2.4	2.0	1.7
			$n_{2 \text{ Eck}}$			183	183	169	183	183
			$n_{2 \text{ th}}$			183	183	169	183	183
24.800	171	0.42	M_2		23	30	46	63	77	91
			c		4.9	3.9	2.6	1.9	1.6	1.3
			$n_{2 \text{ Eck}}$		163	163	163	151	163	163
			$n_{2 \text{ th}}$		163	163	163	151	163	163

$M \dots$ [Nm]
 $n \dots$ [r/min]
 $J \dots$ [kgcm²]

$P \dots$ [kW]
 $I \dots$ [A]
 $i [-]$
 $c [-]$

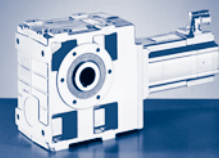

$M_{2GN} \leq 180 \text{ Nm}$

GSS04-2S				06CC41	06FC41	06IC41	09DC41	09FC38	09HC41	09LC41
				...500	...500	...500	...500	...500	...500	...500
i	M_{2GN}	J_G	M_1	0.60	1.20	1.50	2.30	3.10	3.80	4.50
			n_1	4050	4050	4050	4050	3750	4050	4050
			I_{M230}	2.6	2.9	3.2	4.6	5.0	6.8	8.4
			I_{M400}	1.3	1.5	1.6	2.3	2.5	3.4	4.2
			P_N	0.25	0.51	0.64	1.00	1.20	1.60	1.90
			J_M	0.17	0.25	0.33	1.13	1.53	1.93	2.83
27.125	180	0.14	M_2		27	35	54	73	90	107
			c		5.5	4.4	2.9	2.1	1.7	1.5
			$n_{2 \text{ Eck}}$		149	149	149	138	149	149
			$n_{2 \text{ th}}$		149	149	149	138	149	149
31.738	180	0.29	M_2		30	38	59	80	99	117
			c		4.2	3.3	2.2	1.6	1.3	1.1
			$n_{2 \text{ Eck}}$		128	128	128	118	128	128
			$n_{2 \text{ th}}$		128	128	128	118	128	128
34.100	180	0.10	M_2		34	44				
			c		4.7	3.8				
			$n_{2 \text{ Eck}}$		119	119				
			$n_{2 \text{ th}}$		119	119				
39.200	180	0.25	M_2		37	46	72	97	119	
			c		3.6	2.9	1.9	1.4	1.1	
			$n_{2 \text{ Eck}}$		103	103	103	96	103	
			$n_{2 \text{ th}}$		103	103	103	96	103	
43.917	180	0.06	M_2		45	56				
			c		3.9	3.1				
			$n_{2 \text{ Eck}}$		92	92				
			$n_{2 \text{ th}}$		92	92				
50.000	180	0.17	M_2		47	59	91	123		
			c		3.1	2.4	1.6	1.2		
			$n_{2 \text{ Eck}}$		81	81	81	75		
			$n_{2 \text{ th}}$		81	81	81	75		
54.250	180	0.13	M_2	25	52	65	101	136		
			c	5.9	3.0	2.4	1.6	1.2		
			$n_{2 \text{ Eck}}$	75	75	75	75	69		
			$n_{2 \text{ th}}$	75	75	75	75	69		
61.250	180	0.13	M_2	28	57	72	111	150		
			c	5.4	2.7	2.2	1.4	1.0		
			$n_{2 \text{ Eck}}$	66	66	66	66	61		
			$n_{2 \text{ th}}$	66	66	66	66	61		
68.200	180	0.09	M_2	31	65	81				
			c	5.1	2.6	2.1				
			$n_{2 \text{ Eck}}$	59	59	59				
			$n_{2 \text{ th}}$	59	59	59				
77.000	180	0.09	M_2	35	71	90				
			c	4.7	2.3	1.9				
			$n_{2 \text{ Eck}}$	53	53	53				
			$n_{2 \text{ th}}$	53	53	53				
87.833	180	0.06	M_2	40	83	104				
			c	4.3	2.1	1.7				
			$n_{2 \text{ Eck}}$	46	46	46				
			$n_{2 \text{ th}}$	46	46	46				
99.167	180	0.06	M_2	45	92	115				
			c	3.9	1.9	1.6				
			$n_{2 \text{ Eck}}$	41	41	41				
			$n_{2 \text{ th}}$	41	41	41				

$M \dots$ [Nm]
 $n \dots$ [r/min]
 $J \dots$ [kgcm²]

$P \dots$ [kW]
 $I \dots$ [A]
 i [-]
 c [-]

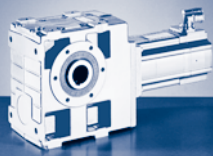

GSS [Nm]

GSS□□-□S (MCS)

$M_{2GN} \leq 360 \text{ Nm}$

GSS05-2S				06CC41	06FC41	06IC41	09DC41	09FC38	09HC41	09LC41	
				...500	...500	...500	...500	...500	...500	...500	
i	M_{2GN}	J_G	M_1	0.60	1.20	1.50	2.30	3.10	3.80	4.50	
			n_1	4050	4050	4050	4050	3750	4050	4050	
			I_{M230}	2.6	2.9	3.2	4.6	5.0	6.8	8.4	
			I_{M400}	1.3	1.5	1.6	2.3	2.5	3.4	4.2	
			P_N	0.25	0.51	0.64	1.00	1.20	1.60	1.90	
			J_M	0.17	0.25	0.33	1.13	1.53	1.93	2.83	
5.639	175	2.82	M_2						18	22	
			c						5.7	4.8	
			$n_{2 \text{ Eck}}$							718	718
			$n_{2 \text{ th}}$							718	718
5.639	223	2.82	M_2								
			c								
			$n_{2 \text{ Eck}}$								
			$n_{2 \text{ th}}$								
7.733	212	1.66	M_2						25	30	
			c						5.2	4.4	
			$n_{2 \text{ Eck}}$							524	524
			$n_{2 \text{ th}}$							524	524
7.733	267	1.66	M_2								
			c								
			$n_{2 \text{ Eck}}$								
			$n_{2 \text{ th}}$								
9.042	251	2.01	M_2				17	23	29	34	
			c				5.8	4.3	3.5	3.0	
			$n_{2 \text{ Eck}}$				448	415	448	448	
			$n_{2 \text{ th}}$				448	415	448	448	
9.897	228	1.10	M_2					26	33	39	
			c					5.9	4.8	4.1	
			$n_{2 \text{ Eck}}$					379	409	409	
			$n_{2 \text{ th}}$					379	409	409	
9.897	271	1.10	M_2								
			c								
			$n_{2 \text{ Eck}}$								
			$n_{2 \text{ th}}$								
10.827	238	0.94	M_2					29	36	43	
			c					5.7	4.7	4.0	
			$n_{2 \text{ Eck}}$					346	374	374	
			$n_{2 \text{ th}}$					346	374	374	
10.827	272	0.94	M_2								
			c								
			$n_{2 \text{ Eck}}$								
			$n_{2 \text{ th}}$								
12.400	279	1.24	M_2					32	40	48	
			c					4.9	4.0	3.4	
			$n_{2 \text{ Eck}}$					302	327	327	
			$n_{2 \text{ th}}$					302	327	327	
13.810	256	0.64	M_2					37	46	55	
			c					5.3	4.4	3.7	
			$n_{2 \text{ Eck}}$					272	293	293	
			$n_{2 \text{ th}}$					272	293	293	
13.810	275	0.64	M_2								
			c								
			$n_{2 \text{ Eck}}$								
			$n_{2 \text{ th}}$								
15.869	301	0.84	M_2					42	51	61	
			c					4.9	4.0	3.4	
			$n_{2 \text{ Eck}}$					236	255	255	
			$n_{2 \text{ th}}$					236	255	255	

$M \dots$ [Nm]
 $n \dots$ [r/min]
 $J \dots$ [kgcm²]

$P \dots$ [kW]
 $I \dots$ [A]
 i [-]
 c [-]

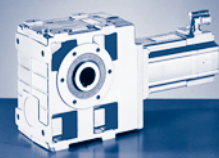

$M_{2GN} \leq 360 \text{ Nm}$

12DC20	12DC41	12HC15	12HC30	12HC35	12LC20	12LC41	GSS05-2S			
...500	...500	...500	...500	...500	...500	...500	M_1	J_G	M_{2GN}	i
5.50	4.30	10.00	8.00	7.50	13.50	11.00	n_1			
1950	4050	1500	3000	3525	1950	4050	$I_M 230$			
5.2	8.8	7.6	10.5		11.8		$I_M 400$			
2.6	4.5	3.8		5.7	5.9	10.2	P_N			
1.10	1.80	1.60	2.50	2.80	2.80	4.70	J_M			
4.12	4.12	7.42	7.42	7.42	10.72	10.72	M_2			
							c	2.82	175	5.639
							n_2			
							Eck			
							n_2			
							th			
	21	50	40	37	68	55	M_2			
	5.1	4.4	3.4	2.9	2.5	2.0	c	2.82	223	5.639
	718	266	532	625	346	718	n_2			
	718	266	532	625	346	718	Eck			
							n_2			
							th			
							M_2			
							c	1.66	212	7.733
							n_2			
							Eck			
							n_2			
							th			
37	29	69	55	51	94	76	M_2			
5.7	4.6	3.8	3.0	2.6	2.3	1.8	c	1.66	267	7.733
252	524	194	388	456	252	524	n_2			
252	524	194	388	456	252	524	Eck			
							n_2			
							th			
42	33	78	62	58	106	86	M_2			
5.1	3.1	3.1	2.6	1.8	2.1	1.2	c	2.01	251	9.042
216	448	166	332	390	216	448	n_2			
216	448	166	332	390	216	448	Eck			
							n_2			
							th			
							M_2			
							c	1.10	228	9.897
							n_2			
							Eck			
							n_2			
							th			
47	37	89	71	66	120	98	M_2			
5.2	4.2	3.0	2.8	2.4	2.1	1.7	c	1.10	271	9.897
197	409	152	303	356	197	409	n_2			
197	409	152	303	356	197	409	Eck			
							n_2			
							th			
							M_2			
							c	0.94	238	10.827
							n_2			
							Eck			
							n_2			
							th			
52	41	97	77	73	132	107	M_2			
4.9	4.1	2.8	2.8	2.4	2.0	1.6	c	0.94	272	10.827
180	374	139	277	326	180	374	n_2			
180	374	139	277	326	180	374	Eck			
							n_2			
							th			
58	45	108	86	81	147	119	M_2			
4.1	3.5	2.5	2.5	2.0	1.7	1.4	c	1.24	279	12.400
157	327	121	242	284	157	327	n_2			
157	327	121	242	284	157	327	Eck			
							n_2			
							th			
							M_2			
							c	0.64	256	13.810
							n_2			
							Eck			
							n_2			
							th			
67	52	125	99	93	170	138	M_2			
3.9	3.8	2.2	2.6	2.2	1.6	1.5	c	0.64	275	13.810
141	293	109	217	255	141	293	n_2			
141	293	109	217	255	141	293	Eck			
							n_2			
							th			
75	58	139	111	104	189	153	M_2			
3.5	3.5	2.1	2.1	2.0	1.4	1.4	c	0.84	301	15.869
123	255	95	189	222	123	255	n_2			
123	255	95	189	222	123	255	Eck			
							n_2			
							th			

$M \dots$ [Nm]
 $n \dots$ [r/min]
 $J \dots$ [kgcm²]

$P \dots$ [kW]
 $I \dots$ [A]
 $i [-]$
 $c [-]$

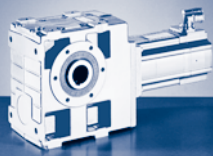

GSS [Nm]

GSS□□-□S (MCS)

$M_{2GN} \leq 360 \text{ Nm}$

GSS05-2S				06CC41	06FC41	06IC41	09DC41	09FC38	09HC41	09LC41
				...500	...500	...500	...500	...500	...500	...500
i	M_{2GN}	J_G	M_1	0.60	1.20	1.50	2.30	3.10	3.80	4.50
			n_1	4050	4050	4050	4050	3750	4050	4050
			I_{M230}	2.6	2.9	3.2	4.6	5.0	6.8	8.4
			I_{M400}	1.3	1.5	1.6	2.3	2.5	3.4	4.2
			P_N	0.25	0.51	0.64	1.00	1.20	1.60	1.90
			J_M	0.17	0.25	0.33	1.13	1.53	1.93	2.83
17.360	311	0.72	M_2					46	56	67
			c				4.6	3.8	3.2	
			$n_{2 \text{ Eck}}$				216	233	233	
			$n_{2 \text{ th}}$				216	233	233	
20.417	253	1.60	M_2				35	48	59	70
			c				3.6	2.6	2.2	1.8
			$n_{2 \text{ Eck}}$				198	184	198	198
			$n_{2 \text{ th}}$				198	184	198	198
22.143	337	0.50	M_2				43	59	73	87
			c				5.3	3.9	3.2	2.7
			$n_{2 \text{ Eck}}$				183	169	183	183
			$n_{2 \text{ th}}$				183	169	183	183
24.800	280	1.06	M_2				44	61	75	89
			c				3.8	2.9	2.3	2.0
			$n_{2 \text{ Eck}}$				163	151	163	163
			$n_{2 \text{ th}}$				163	151	163	163
27.125	360	0.38	M_2				53	73	90	107
			c				4.6	3.4	2.8	2.4
			$n_{2 \text{ Eck}}$				149	138	149	149
			$n_{2 \text{ th}}$				149	138	149	149
31.738	306	0.73	M_2			37	58	79	97	115
			c			5.4	3.5	2.6	2.1	1.8
			$n_{2 \text{ Eck}}$			128	128	118	128	128
			$n_{2 \text{ th}}$			128	128	118	128	128
35.306	296	0.23	M_2			44				
			c			5.9				
			$n_{2 \text{ Eck}}$			115				
			$n_{2 \text{ th}}$			115				
35.306	360	0.23	M_2				70	95	117	139
			c				3.9	2.9	2.4	2.0
			$n_{2 \text{ Eck}}$				115	106	115	115
			$n_{2 \text{ th}}$				115	106	115	115
39.200	323	0.61	M_2		35	45	70	96	118	140
			c		5.9	4.7	3.1	2.3	1.9	1.6
			$n_{2 \text{ Eck}}$		103	103	103	96	103	103
			$n_{2 \text{ th}}$		103	103	103	96	103	103
43.917	306	0.17	M_2			56				
			c			5.1				
			$n_{2 \text{ Eck}}$			92				
			$n_{2 \text{ th}}$			92				
43.917	360	0.17	M_2				87	119	146	174
			c				3.4	2.5	2.0	1.7
			$n_{2 \text{ Eck}}$				92	85	92	92
			$n_{2 \text{ th}}$				92	85	92	92
50.000	353	0.44	M_2		46	58	91	123	152	181
			c		5.0	4.0	2.6	1.9	1.6	1.3
			$n_{2 \text{ Eck}}$		81	81	81	75	81	81
			$n_{2 \text{ th}}$		81	81	81	75	81	81
54.250	360	0.34	M_2		51	65	101	137	169	200
			c		4.8	3.8	2.5	1.9	1.5	1.3
			$n_{2 \text{ Eck}}$		75	75	75	69	75	75
			$n_{2 \text{ th}}$		75	75	75	69	75	75

$M \dots$ [Nm]
 $n \dots$ [r/min]
 $J \dots$ [kgcm²]

$P \dots$ [kW]
 $I \dots$ [A]
 $i \dots$ [-]
 $c \dots$ [-]

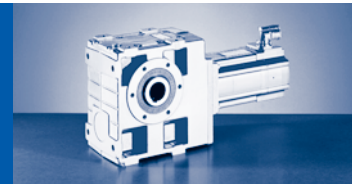

$M_{2GN} \leq 360 \text{ Nm}$

12DC20	12DC41	12HC15	12HC30	12HC35	12LC20	12LC41	GSS05-2S			
...500	...500	...500	...500	...500	...500	...500				
5.50	4.30	10.00	8.00	7.50	13.50	11.00	M_1	J_G	M_{2GN}	i
1950	4050	1500	3000	3525	1950	4050	n_1			
5.2	8.8	7.6	10.5		11.8		I_{M230}			
2.6	4.5	3.8		5.7	5.9	10.2	I_{M400}			
1.10	1.80	1.60	2.50	2.80	2.80	4.70	P_N			
4.12	4.12	7.42	7.42	7.42	10.72	10.72	J_M			
83	64	152	122	114	207	168	M_2			
3.3	3.3	2.0	2.0	1.9	1.3	1.3	c	0.72	311	17.360
112	233	86	173	203	112	233	$n_{2\text{ Eck}}$			
112	233	86	173	203	112	233	$n_{2\text{ th}}$			
88	67	163	128	118	220		M_2			
2.5	1.9	1.5	1.4	1.1	1.0		c	1.60	253	20.417
96	198	74	147	173	96		$n_{2\text{ Eck}}$			
96	198	73	147	173	96		$n_{2\text{ th}}$			
106	83	195	156	146	265	215	M_2			
2.8	2.8	1.7	1.7	1.6	1.1	1.1	c	0.50	337	22.143
88	183	68	136	159	88	183	$n_{2\text{ Eck}}$			
88	183	68	135	159	88	183	$n_{2\text{ th}}$			
110	85	203	161	150			M_2			
2.2	2.1	1.4	1.3	1.2			c	1.06	280	24.800
79	163	61	121	142			$n_{2\text{ Eck}}$			
79	163	60	121	142			$n_{2\text{ th}}$			
130	102	240	192	180			M_2			
2.4	2.5	1.5	1.5	1.4			c	0.38	360	27.125
72	149	55	111	130			$n_{2\text{ Eck}}$			
72	149	55	111	130			$n_{2\text{ th}}$			
142	110	261	208	194			M_2			
1.9	1.9	1.2	1.1	1.1			c	0.73	306	31.738
61	128	47	95	111			$n_{2\text{ Eck}}$			
61	128	47	95	111			$n_{2\text{ th}}$			
							M_2			
							c	0.23	296	35.306
							$n_{2\text{ Eck}}$			
							$n_{2\text{ th}}$			
							M_2			
							c	0.23	360	35.306
							$n_{2\text{ Eck}}$			
							$n_{2\text{ th}}$			
173	134	317					M_2			
1.6	1.6	1.0					c	0.61	323	39.200
50	103	38					$n_{2\text{ Eck}}$			
50	103	38					$n_{2\text{ th}}$			
							M_2			
							c	0.17	306	43.917
							$n_{2\text{ Eck}}$			
							$n_{2\text{ th}}$			
							M_2			
							c	0.17	360	43.917
							$n_{2\text{ Eck}}$			
							$n_{2\text{ th}}$			
221	172						M_2			
1.4	1.4						c	0.44	353	50.000
39	81						$n_{2\text{ Eck}}$			
39	81						$n_{2\text{ th}}$			
245	191						M_2			
1.3	1.3						c	0.34	360	54.250
36	75						$n_{2\text{ Eck}}$			
36	75						$n_{2\text{ th}}$			

M ... [Nm]
n ... [r/min]
J ... [kgcm²]

P ... [kW]
I ... [A]
i [-]
c [-]

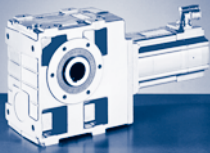

GSS [Nm]

GSS□□-□S (MCS)

$M_{2GN} \leq 360 \text{ Nm}$

GSS05-2S				06CC41	06FC41	06IC41	09DC41	09FC38	09HC41	09LC41
				...500	...500	...500	...500	...500	...500	...500
i	M_{2GN}	J_G	M_1	0.60	1.20	1.50	2.30	3.10	3.80	4.50
			n_1	4050	4050	4050	4050	3750	4050	4050
			I_{M230}	2.6	2.9	3.2	4.6	5.0	6.8	8.4
			I_{M400}	1.3	1.5	1.6	2.3	2.5	3.4	4.2
			P_N	0.25	0.51	0.64	1.00	1.20	1.60	1.90
			J_M	0.17	0.25	0.33	1.13	1.53	1.93	2.83
61.250	360	0.33	M_2		57	72	112	152	187	222
			c		4.4	3.5	2.3	1.7	1.4	1.2
			$n_{2 \text{ Eck}}$		66	66	66	61	66	66
			$n_{2 \text{ th}}$		66	66	66	61	66	66
70.611	360	0.21	M_2		67	85	132	179	220	262
			c		4.1	3.2	2.1	1.6	1.3	1.1
			$n_{2 \text{ Eck}}$		57	57	57	53	57	57
			$n_{2 \text{ th}}$		57	57	57	53	57	57
79.722	360	0.21	M_2		75	94	147	199	245	
			c		3.7	3.0	1.9	1.4	1.2	
			$n_{2 \text{ Eck}}$		51	51	51	47	51	
			$n_{2 \text{ th}}$		51	51	51	47	51	
87.833	360	0.15	M_2		84	106	165	223	275	
			c		3.5	2.8	1.8	1.4	1.1	
			$n_{2 \text{ Eck}}$		46	46	46	43	46	
			$n_{2 \text{ th}}$		46	46	46	43	46	
99.167	360	0.15	M_2		94	118	183	248	305	
			c		3.2	2.6	1.7	1.3	1.0	
			$n_{2 \text{ Eck}}$		41	41	41	38	41	
			$n_{2 \text{ th}}$		41	41	41	38	41	
113.667	360	0.10	M_2	53	110	138				
			c	6.0	3.0	2.4				
			$n_{2 \text{ Eck}}$	36	36	36				
			$n_{2 \text{ th}}$	36	36	36				
128.333	360	0.09	M_2	59	122	154				
			c	5.5	2.8	2.2				
			$n_{2 \text{ Eck}}$	32	32	32				
			$n_{2 \text{ th}}$	32	32	32				
137.950	360	0.07	M_2	65	134	168				
			c	5.3	2.6	2.1				
			$n_{2 \text{ Eck}}$	29	29	29				
			$n_{2 \text{ th}}$	29	29	29				
155.750	360	0.07	M_2	72	149	187				
			c	4.8	2.4	1.9				
			$n_{2 \text{ Eck}}$	26	26	26				
			$n_{2 \text{ th}}$	26	26	26				

$M \dots$ [Nm]
 $n \dots$ [r/min]
 $J \dots$ [kgcm²]

$P \dots$ [kW]
 $I \dots$ [A]
 $i \dots$ [-]
 $c \dots$ [-]

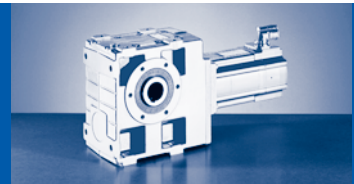

$M_{2GN} \leq 360 \text{ Nm}$

12DC20	12DC41	12HC15	12HC30	12HC35	12LC20	12LC41	GSS05-2S			
...500	...500	...500	...500	...500	...500	...500	M_1	J_G	M_{2GN}	i
5.50	4.30	10.00	8.00	7.50	13.50	11.00	n_1			
1950	4050	1500	3000	3525	1950	4050	I_{M230}			
5.2	8.8	7.6	10.5		11.8		I_{M400}			
2.6	4.5	3.8		5.7	5.9	10.2	P_N			
1.10	1.80	1.60	2.50	2.80	2.80	4.70	J_M			
4.12	4.12	7.42	7.42	7.42	10.72	10.72	M_2			
272	212						c			
1.2	1.2						n_{2Eck}	0.33	360	61.250
32	66						n_{2th}			
32	66						M_2			
							c			
							n_{2Eck}	0.21	360	70.611
							n_{2th}			
							M_2			
							c			
							n_{2Eck}	0.21	360	79.722
							n_{2th}			
							M_2			
							c			
							n_{2Eck}	0.15	360	87.833
							n_{2th}			
							M_2			
							c			
							n_{2Eck}	0.15	360	99.167
							n_{2th}			
							M_2			
							c			
							n_{2Eck}	0.10	360	113.667
							n_{2th}			
							M_2			
							c			
							n_{2Eck}	0.09	360	128.333
							n_{2th}			
							M_2			
							c			
							n_{2Eck}	0.07	360	137.950
							n_{2th}			
							M_2			
							c			
							n_{2Eck}	0.07	360	155.750
							n_{2th}			

M ... [Nm]
n ... [r/min]
J ... [kgcm²]

P ... [kW]
I ... [A]
i [-]
c [-]

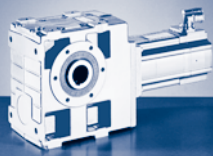

GSS [Nm]

GSS□□-□S (MCS)

$M_{2GN} \leq 360 \text{ Nm}$

GSS05-3S				06CC41	06FC41	06IC41	09DC41
i	M_{2GN}	J_G	M_1	...S00	...S00	...S00	...S00
			n_1	0.60	1.20	1.50	2.30
			I_{M230}	4050	4050	4050	4050
			I_{M400}	2.6	2.9	3.2	4.6
			P_N	1.3	1.5	1.6	2.3
			J_M	0.25	0.51	0.64	1.00
			M_2	0.17	0.25	0.33	1.13
125.476	339	0.15	c	63	129	163	251
			$n_{2 \text{ Eck}}$	4.0	2.0	1.6	1.0
			$n_{2 \text{ th}}$	32	32	32	32
			$n_{2 \text{ th}}$	32	32	32	32
153.708	356	0.12	M_2	77	158	198	
			c	3.5	1.7	1.4	
			$n_{2 \text{ Eck}}$	26	26	26	
			$n_{2 \text{ th}}$	26	26	26	
193.233	360	0.08	M_2	97	197	247	
			c	3.0	1.5	1.2	
			$n_{2 \text{ Eck}}$	21	21	21	
			$n_{2 \text{ th}}$	21	21	21	
222.133	360	0.21	M_2	103	210	263	
			c	3.4	1.7	1.4	
			$n_{2 \text{ Eck}}$	18	18	18	
			$n_{2 \text{ th}}$	18	18	18	
250.952	360	0.15	M_2	118	240	301	
			c	3.0	1.5	1.2	
			$n_{2 \text{ Eck}}$	16	16	16	
			$n_{2 \text{ th}}$	16	16	16	
283.333	360	0.15	M_2	130	265	332	
			c	2.7	1.3	1.1	
			$n_{2 \text{ Eck}}$	14	14	14	
			$n_{2 \text{ th}}$	14	14	14	
307.417	360	0.12	M_2	143	291		
			c	2.5	1.2		
			$n_{2 \text{ Eck}}$	13	13		
			$n_{2 \text{ th}}$	13	13		
347.083	360	0.11	M_2	158	321		
			c	2.2	1.1		
			$n_{2 \text{ Eck}}$	12	12		
			$n_{2 \text{ th}}$	12	12		
386.467	360	0.08	M_2	178			
			c	2.0			
			$n_{2 \text{ Eck}}$	11			
			$n_{2 \text{ th}}$	10			
436.333	360	0.08	M_2	197			
			c	1.8			
			$n_{2 \text{ Eck}}$	9			
			$n_{2 \text{ th}}$	9			
497.722	360	0.05	M_2	226			
			c	1.6			
			$n_{2 \text{ Eck}}$	8			
			$n_{2 \text{ th}}$	8			
561.944	360	0.05	M_2	249			
			c	1.4			
			$n_{2 \text{ Eck}}$	7			
			$n_{2 \text{ th}}$	7			

$M \dots$ [Nm]
 $n \dots$ [r/min]
 $J \dots$ [kgcm²]

$P \dots$ [kW]
 $I \dots$ [A]
 $i \dots$ [-]
 $c \dots$ [-]

GSS [Nm]
GSS□□-□S (MCS)

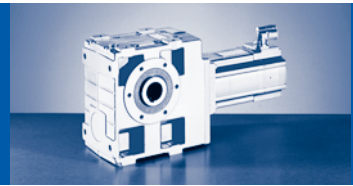

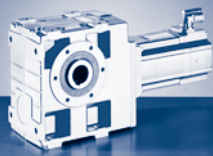

GSS [Nm]

GSS□□-□S (MCS)

$M_{2GN} \leq 720 \text{ Nm}$

GSS06-2S				06FC41	06IC41	09DC41	09FC38	09HC41	09LC41	12DC20	12DC41	12HC15	12HC30	
				...500	...500	...500	...500	...500	...500	...500	...500	...500	...500	
i	M_{2GN}	J_G	M_1	1.20	1.50	2.30	3.10	3.80	4.50	5.50	4.30	10.00	8.00	
			n_1	4050	4050	4050	3750	4050	4050	1950	4050	1500	3000	
			I_{M230}	2.9	3.2	4.6	5.0	6.8	8.4	5.2	8.8	7.6	10.5	
			I_{M400}	1.5	1.6	2.3	2.5	3.4	4.2	2.6	4.5	3.8		
			P_N	0.51	0.64	1.00	1.20	1.60	1.90	1.10	1.80	1.60	2.50	
			J_M	0.25	0.33	1.13	1.53	1.93	2.83	4.12	4.12	7.42	7.42	
5.833	308	6.97	M_2								22	51	41	
			c									5.4	5.8	4.5
			$n_{2 \text{ Eck}}$									694	257	514
			$n_{2 \text{ th}}$									694	257	514
5.833	356	6.97	M_2											
			c											
			$n_{2 \text{ Eck}}$											
			$n_{2 \text{ th}}$											
8.000	353	4.22	M_2									71	56	
			c									4.8	4.6	
			$n_{2 \text{ Eck}}$									188	375	
			$n_{2 \text{ th}}$									188	375	
8.000	489	4.22	M_2											
			c											
			$n_{2 \text{ Eck}}$											
			$n_{2 \text{ th}}$											
9.042	417	5.54	M_2								33	77	63	
			c									5.9	5.1	3.9
			$n_{2 \text{ Eck}}$									448	166	332
			$n_{2 \text{ th}}$									448	166	332
10.238	380	2.81	M_2									91	72	
			c									4.0	4.4	
			$n_{2 \text{ Eck}}$									147	293	
			$n_{2 \text{ th}}$									147	293	
10.238	522	2.81	M_2											
			c											
			$n_{2 \text{ Eck}}$											
			$n_{2 \text{ th}}$											
11.200	308	2.39	M_2						44					
			c						6.0					
			$n_{2 \text{ Eck}}$						362					
			$n_{2 \text{ th}}$						362					
11.200	398	2.39	M_2									100	79	
			c									3.9	4.2	
			$n_{2 \text{ Eck}}$									134	268	
			$n_{2 \text{ th}}$									134	268	
11.200	524	2.39	M_2											
			c											
			$n_{2 \text{ Eck}}$											
			$n_{2 \text{ th}}$											
12.400	523	3.46	M_2								46	107	87	
			c									5.3	4.7	3.6
			$n_{2 \text{ Eck}}$									327	121	242
			$n_{2 \text{ th}}$									327	121	242
14.286	331	1.63	M_2						56					
			c						5.6					
			$n_{2 \text{ Eck}}$						284					
			$n_{2 \text{ th}}$						284					
14.286	428	1.63	M_2							69	53	129	102	
			c							5.9	5.9	3.3	4.1	
			$n_{2 \text{ Eck}}$								137	284	105	210
			$n_{2 \text{ th}}$								137	284	105	210

$M \dots$ [Nm]
 $n \dots$ [r/min]
 $J \dots$ [kgcm²]

$P \dots$ [kW]
 $I \dots$ [A]
 $i \dots$ [-]
 $c \dots$ [-]

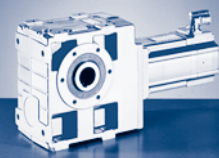

$M_{2GN} \leq 720 \text{ Nm}$

12HC35	12LC20	12LC41	14DC15	14DC36	14HC15	14HC32	14LC15	14LC32	14PC14	14PC32	GSS06-2S			
...500	...500	...500	...500	...500	...500	...500	...500	...500	...500	...500	M_1	J_G	M_{2GN}	i
7.50	13.50	11.00	9.20	7.50	16.00	14.00	23.00	17.20	30.00	21.00	n_1			
3525	1950	4050	1500	3600	1500	3225	1500	3225	1350	3225	I_{M230}			
	11.8										I_{M400}			
5.7	5.9	10.2	4.5	7.5	6.6	11.9	9.7	15.0	10.8	15.6	P_N			
2.80	2.80	4.70	1.45	2.80	2.50	4.70	3.60	5.80	4.20	7.10	J_M			
7.42	10.72	10.72	8.22	8.22	14.32	14.32	23.44	23.44	34.74	34.82	M_2			
38	70	57									c	6.97	308	5.833
3.7	3.9	2.1									$n_{2 \text{ Eck}}$			
604	334	694									$n_{2 \text{ th}}$			
604	334	694									M_2			
				39	83	73	121	90	158	110	c	6.97	356	5.833
				3.1	4.2	2.0	2.9	1.6	2.2	1.3	$n_{2 \text{ Eck}}$			
				617	257	553	257	553	231	553	$n_{2 \text{ th}}$			
				615	257	553	257	553	231	553	M_2			
53	96	79									c	4.22	353	8.000
4.1	3.6	2.4									$n_{2 \text{ Eck}}$			
441	244	506									$n_{2 \text{ th}}$			
441	244	506									M_2			
				53	114	101	166	124	218	152	c	4.22	489	8.000
				3.5	4.2	2.2	2.9	1.8	2.2	1.5	$n_{2 \text{ Eck}}$			
				450	188	403	188	403	169	403	$n_{2 \text{ th}}$			
				449	188	403	188	403	169	403	M_2			
59	107	88	71	59	127	112	184	139	242	170	c	5.54	417	9.042
3.7	3.0	2.3	5.6	3.4	3.2	2.0	2.2	1.6	1.7	1.3	$n_{2 \text{ Eck}}$			
390	216	448	166	398	166	357	166	357	149	357	$n_{2 \text{ th}}$			
390	216	448	166	397	166	357	166	357	149	357	M_2			
68	124	101									c	2.81	380	10.238
4.0	3.0	2.5									$n_{2 \text{ Eck}}$			
344	191	396									$n_{2 \text{ th}}$			
344	190	396									M_2			
				68	147	129	214	160	280	195	c	2.81	522	10.238
				3.6	3.5	2.2	2.4	1.8	1.9	1.4	$n_{2 \text{ Eck}}$			
				352	147	315	147	315	132	315	$n_{2 \text{ th}}$			
				351	147	315	147	315	132	315	M_2			
											c	2.39	308	11.200
											$n_{2 \text{ Eck}}$			
											$n_{2 \text{ th}}$			
74	136	111									M_2			
4.0	2.9	2.4									c	2.39	398	11.200
315	174	362									$n_{2 \text{ Eck}}$			
315	174	362									$n_{2 \text{ th}}$			
			90	75	161	142	234	175	307	214	M_2			
			5.5	3.6	3.2	2.1	2.2	1.7	1.7	1.4	c	2.39	524	11.200
			134	321	134	288	134	288	121	288	$n_{2 \text{ Eck}}$			
			134	321	134	288	134	288	121	288	$n_{2 \text{ th}}$			
81	147	121	98	82	174	155	252	191	331	234	M_2			
3.3	2.7	2.1	5.1	3.1	2.9	1.8	2.1	1.5	1.6	1.2	c	3.46	523	12.400
284	157	327	121	290	121	260	121	260	109	260	$n_{2 \text{ Eck}}$			
284	157	327	121	290	121	260	121	260	109	260	$n_{2 \text{ th}}$			
											M_2			
											c	1.63	331	14.286
											$n_{2 \text{ Eck}}$			
											$n_{2 \text{ th}}$			
95	175	142									M_2			
3.7	2.4	2.3									c	1.63	428	14.286
247	137	284									$n_{2 \text{ Eck}}$			
247	137	284									$n_{2 \text{ th}}$			

M ... [Nm]
n ... [r/min]
J ... [kgcm²]

P ... [kW]
I ... [A]
i [-]
c [-]

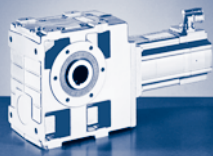

GSS [Nm]

GSS□□-□S (MCS)

$M_{2GN} \leq 720 \text{ Nm}$

GSS06-2S				06FC41	06IC41	09DC41	09FC38	09HC41	09LC41	12DC20	12DC41	12HC15	12HC30
				...500	...500	...500	...500	...500	...500	...500	...500	...500	...500
i	M_{2GN}	J_G	M_1	1.20	1.50	2.30	3.10	3.80	4.50	5.50	4.30	10.00	8.00
			n_1	4050	4050	4050	3750	4050	4050	1950	4050	1500	3000
			I_{M230}	2.9	3.2	4.6	5.0	6.8	8.4	5.2	8.8	7.6	10.5
			I_{M400}	1.5	1.6	2.3	2.5	3.4	4.2	2.6	4.5	3.8	
			P_N	0.51	0.64	1.00	1.20	1.60	1.90	1.10	1.80	1.60	2.50
			J_M	0.25	0.33	1.13	1.53	1.93	2.83	4.12	4.12	7.42	7.42
14.286	528	1.63	M_2 c $n_{2 \text{ Eck}}$ $n_{2 \text{ th}}$										
15.869	443	2.35	M_2 c $n_{2 \text{ Eck}}$ $n_{2 \text{ th}}$					51 5.6 255 255	62 4.8 255 255				
15.869	572	2.35	M_2 c $n_{2 \text{ Eck}}$ $n_{2 \text{ th}}$							59 5.0 255 255	137 4.0 95 95	111 3.3 189 189	
15.869	605	2.35	M_2 c $n_{2 \text{ Eck}}$ $n_{2 \text{ th}}$										
17.360	462	2.01	M_2 c $n_{2 \text{ Eck}}$ $n_{2 \text{ th}}$					56 5.5 233 233	67 4.6 233 233				
17.360	597	2.01	M_2 c $n_{2 \text{ Eck}}$ $n_{2 \text{ th}}$							64 4.9 233 233	150 3.9 86 86	122 3.3 173 173	
17.360	624	2.01	M_2 c $n_{2 \text{ Eck}}$ $n_{2 \text{ th}}$										
20.417	488	4.17	M_2 c $n_{2 \text{ Eck}}$ $n_{2 \text{ th}}$							90 4.1 96 96	71 3.3 198 198	166 2.9 74 73	134 2.2 147 147
22.143	494	1.39	M_2 c $n_{2 \text{ Eck}}$ $n_{2 \text{ th}}$					72 5.1 183 183	86 4.3 183 183				
22.143	638	1.39	M_2 c $n_{2 \text{ Eck}}$ $n_{2 \text{ th}}$							103 5.6 88 88	82 4.5 183 183	192 3.3 68 68	155 3.0 136 135
22.143	673	1.39	M_2 c $n_{2 \text{ Eck}}$ $n_{2 \text{ th}}$										
24.800	561	3.06	M_2 c $n_{2 \text{ Eck}}$ $n_{2 \text{ th}}$							110 4.0 79 79	88 3.1 163 163	202 2.7 61 60	165 2.1 121 121
27.125	518	1.04	M_2 c $n_{2 \text{ Eck}}$ $n_{2 \text{ th}}$				71 5.9 138 138	88 4.9 149 149	106 4.1 149 149				

$M \dots$ [Nm]
 $n \dots$ [r/min]
 $J \dots$ [kgcm²]

$P \dots$ [kW]
 $I \dots$ [A]
 $i \dots$ [-]
 $c \dots$ [-]

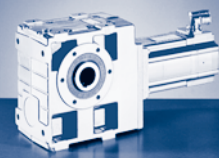

$M_{2GN} \leq 720 \text{ Nm}$

12HC35	12LC20	12LC41	14DC15	14DC36	14HC15	14HC32	14LC15	14LC32	14PC14	14PC32	GSS06-2S			
...500	...500	...500	...500	...500	...500	...500	...500	...500	...500	...500	M_1	J_G	M_{2GN}	i
7.50	13.50	11.00	9.20	7.50	16.00	14.00	23.00	17.20	30.00	21.00	n_1			
3525	1950	4050	1500	3600	1500	3225	1500	3225	1350	3225	I_{M230}			
	11.8										I_{M400}			
5.7	5.9	10.2	4.5	7.5	6.6	11.9	9.7	15.0	10.8	15.6	P_N			
2.80	2.80	4.70	1.45	2.80	2.50	4.70	3.60	5.80	4.20	7.10	J_M			
7.42	10.72	10.72	8.22	8.22	14.32	14.32	23.44	23.44	34.74	34.82	M_2			
			117	96	208	182	301	224	394	274	c	1.63	528	14.286
			4.4	3.4	2.5	2.0	1.7	1.6	1.3	1.3	n_2 Eck			
			105	252	105	226	105	226	95	226	n_2 th			
			105	251	105	226	105	226	95	226	M_2			
											c	2.35	443	15.869
											n_2 Eck			
											n_2 th			
105	189	155									M_2			
3.1	2.6	2.0									c	2.35	572	15.869
222	123	255									n_2 Eck			
222	123	255									n_2 th			
			125	105	223	198	323	244	423	299	M_2			
			4.6	2.9	2.7	1.7	1.9	1.4	1.4	1.1	c	2.35	605	15.869
			95	227	95	203	95	203	85	203	n_2 Eck			
			95	226	95	203	95	203	85	203	n_2 th			
											M_2			
											c	2.01	462	17.360
											n_2 Eck			
											n_2 th			
114	206	170									M_2			
3.0	2.5	1.9									c	2.01	597	17.360
203	112	233									n_2 Eck			
203	112	233									n_2 th			
			137	115	244	217	353	267	463	327	M_2			
			4.4	2.8	2.5	1.6	1.8	1.3	1.3	1.1	c	2.01	624	17.360
			86	207	86	186	86	186	78	186	n_2 Eck			
			86	207	86	186	86	186	78	186	n_2 th			
125	227	185	152	125	268	236	388				M_2			
2.1	1.7	1.3	3.1	1.9	1.8	1.1	1.3				c	4.17	488	20.417
173	96	198	74	176	74	158	74				n_2 Eck			
173	96	198	73	176	73	158	73				n_2 th			
											M_2			
											c	1.39	494	22.143
											n_2 Eck			
											n_2 th			
146	263	217									M_2			
2.8	2.3	1.8									c	1.39	638	22.143
159	88	183									n_2 Eck			
159	88	183									n_2 th			
			175	146	310	277	450	341	589	417	M_2			
			3.7	2.6	2.1	1.5	1.5	1.2	1.1	1.0	c	1.39	673	22.143
			68	163	68	146	68	146	61	146	n_2 Eck			
			68	162	68	146	68	146	61	146	n_2 th			
155	279	229	186	155	328	292	474				M_2			
2.0	1.6	1.2	3.0	1.8	1.7	1.1	1.2				c	3.06	561	24.800
142	79	163	61	145	61	130	61				n_2 Eck			
142	79	163	60	145	60	130	60				n_2 th			
											M_2			
											c	1.04	518	27.125
											n_2 Eck			
											n_2 th			

M ... [Nm]
n ... [r/min]
J ... [kgcm²]

P ... [kW]
I ... [A]
i [-]
c [-]

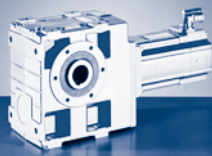

GSS [Nm]

GSS□□-□S (MCS)

$M_{2GN} \leq 720 \text{ Nm}$

GSS06-2S				06FC41	06IC41	09DC41	09FC38	09HC41	09LC41	12DC20	12DC41	12HC15	12HC30	
				...500	...500	...500	...500	...500	...500	...500	...500	...500	...500	
i	M_{2GN}	J_G	M_1	1.20	1.50	2.30	3.10	3.80	4.50	5.50	4.30	10.00	8.00	
			n_1	4050	4050	4050	3750	4050	4050	1950	4050	1500	3000	
			I_{M230}	2.9	3.2	4.6	5.0	6.8	8.4	5.2	8.8	7.6	10.5	
			I_{M400}	1.5	1.6	2.3	2.5	3.4	4.2	2.6	4.5	3.8		
			P_N	0.51	0.64	1.00	1.20	1.60	1.90	1.10	1.80	1.60	2.50	
			J_M	0.25	0.33	1.13	1.53	1.93	2.83	4.12	4.12	7.42	7.42	
27.125	669	1.04	M_2							127	101	235	190	
			c							4.8	4.3	2.8	2.9	
			$n_{2 \text{ Eck}}$								72	149	55	111
			$n_{2 \text{ th}}$								72	149	55	111
27.125	718	1.04	M_2											
			c											
			$n_{2 \text{ Eck}}$											
			$n_{2 \text{ th}}$											
31.738	609	2.10	M_2			58	80	99	118	141	112	259	211	
			c			5.5	4.1	3.3	2.8	3.7	2.9	2.3	2.0	
			$n_{2 \text{ Eck}}$			128	118	128	128	61	128	47	95	
			$n_{2 \text{ th}}$			128	118	128	128	61	128	47	95	
35.306	537	0.66	M_2				93	115	138					
			c				5.5	4.5	3.8					
			$n_{2 \text{ Eck}}$				106	115	115					
			$n_{2 \text{ th}}$				106	115	115					
35.306	693	0.66	M_2							166	131	306	248	
			c							4.1	4.0	2.2	2.5	
			$n_{2 \text{ Eck}}$								55	115	43	85
			$n_{2 \text{ th}}$								55	115	42	85
39.200	637	1.64	M_2			71	98	121	144	173	137	317	258	
			c			5.1	3.8	3.1	2.6	3.2	2.7	2.0	1.8	
			$n_{2 \text{ Eck}}$			103	96	103	103	50	103	38	77	
			$n_{2 \text{ th}}$			103	96	103	103	50	103	38	77	
43.917	554	0.48	M_2				116	144	172					
			c				4.7	3.8	3.2					
			$n_{2 \text{ Eck}}$				85	92	92					
			$n_{2 \text{ th}}$				85	92	92					
43.917	715	0.48	M_2							207	163	380	308	
			c							3.4	3.6	1.9	2.1	
			$n_{2 \text{ Eck}}$								44	92	34	68
			$n_{2 \text{ th}}$								44	92	34	68
50.000	693	1.16	M_2			91	125	154	183	221	175	403	328	
			c			4.8	3.5	2.9	2.4	2.7	2.5	1.7	1.7	
			$n_{2 \text{ Eck}}$			81	75	81	81	39	81	30	60	
			$n_{2 \text{ th}}$			81	75	81	81	39	81	30	60	
54.250	720	0.96	M_2			100	136	168	200	241	191	440	359	
			c			4.7	3.5	2.9	2.4	2.7	2.5	1.6	1.6	
			$n_{2 \text{ Eck}}$			75	69	75	75	36	75	28	55	
			$n_{2 \text{ th}}$			75	69	75	75	36	75	28	55	
61.250	720	0.89	M_2			112	153	188	224	270	214	492	402	
			c			4.5	3.3	2.7	2.3	2.4	2.4	1.5	1.5	
			$n_{2 \text{ Eck}}$			66	61	66	66	32	66	25	49	
			$n_{2 \text{ th}}$			66	61	66	66	32	66	24	49	
70.611	720	0.61	M_2			130	177	218	260	314	248	569	465	
			c			4.2	3.1	2.5	2.1	2.2	2.2	1.3	1.4	
			$n_{2 \text{ Eck}}$			57	53	57	57	28	57	21	43	
			$n_{2 \text{ th}}$			57	53	57	57	28	57	21	42	
79.722	720	0.57	M_2		93	146	199	245	291	351	278	635	520	
			c		5.8	3.8	2.8	2.3	1.9	2.0	2.0	1.1	1.2	
			$n_{2 \text{ Eck}}$		51	51	47	51	51	25	51	19	38	
			$n_{2 \text{ th}}$		51	51	47	51	51	24	51	19	38	

$M \dots$ [Nm]
 $n \dots$ [r/min]
 $J \dots$ [kgcm²]

$P \dots$ [kW]
 $I \dots$ [A]
 $i \dots$ [-]
 $c \dots$ [-]

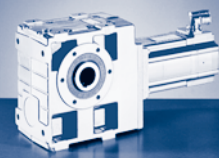

$M_{2GN} \leq 720 \text{ Nm}$

12HC35	12LC20	12LC41	14DC15	14DC36	14HC15	14HC32	14LC15	14LC32	14PC14	14PC32	GSS06-2S			
...500	...500	...500	...500	...500	...500	...500	...500	...500	...500	...500	M_1	J_G	M_{2GN}	i
7.50	13.50	11.00	9.20	7.50	16.00	14.00	23.00	17.20	30.00	21.00	n_1			
3525	1950	4050	1500	3600	1500	3225	1500	3225	1350	3225	I_{M230}			
	11.8										I_{M400}			
5.7	5.9	10.2	4.5	7.5	6.6	11.9	9.7	15.0	10.8	15.6	P_N			
2.80	2.80	4.70	1.45	2.80	2.50	4.70	3.60	5.80	4.20	7.10	J_M			
7.42	10.72	10.72	8.22	8.22	14.32	14.32	23.44	23.44	34.74	34.82	M_2			
179	322	265									c			
2.7	2.0	1.7									n_{2Eck}	1.04	669	27.125
130	72	149									n_{2th}			
130	72	149									M_2			
			215	179	380	339	550	417			c			
			3.3	2.5	1.9	1.4	1.3	1.2			n_{2Eck}	1.04	718	27.125
			55	133	55	119	55	119			n_{2th}			
			55	132	55	119	55	119			M_2			
198	355	293	237	199	418		604				c			
1.8	1.5	1.1	2.5	1.7	1.5		1.0				n_{2Eck}	2.10	609	31.738
111	61	128	47	113	47		47				n_{2th}			
111	61	128	47	113	47		47				M_2			
											c			
											n_{2Eck}	0.66	537	35.306
											n_{2th}			
233	419	345									M_2			
2.5	1.7	1.6									c			
100	55	115									n_{2Eck}	0.66	693	35.306
100	55	115									n_{2th}			
242	435	358	291	243	512						M_2			
1.7	1.3	1.1	2.2	1.6	1.2						c			
90	50	103	38	92	38						n_{2Eck}	1.64	637	39.200
90	50	103	38	92	38						n_{2th}			
											M_2			
											c			
											n_{2Eck}	0.48	554	43.917
											n_{2th}			
290	521	428									M_2			
2.1	1.4	1.4									c			
80	44	92									n_{2Eck}	0.48	715	43.917
80	44	92									n_{2th}			
309	553		370	309	650						M_2			
1.6	1.1		1.9	1.5	1.1						c			
71	39		30	72	30						n_{2Eck}	1.16	693	50.000
71	39		30	72	30						n_{2th}			
337	604		404	338	710						M_2			
1.6	1.1		1.8	1.5	1.0						c			
65	36		28	66	28						n_{2Eck}	0.96	720	54.250
65	36		28	66	28						n_{2th}			
378			452	378							M_2			
1.4			1.6	1.4							c			
58			25	59							n_{2Eck}	0.89	720	61.250
58			24	59							n_{2th}			
437											M_2			
1.3											c			
50											n_{2Eck}	0.61	720	70.611
50											n_{2th}			
490											M_2			
1.2											c			
44											n_{2Eck}	0.57	720	79.722
44											n_{2th}			

$M \dots$ [Nm]
 $n \dots$ [r/min]
 $J \dots$ [kgcm²]

$P \dots$ [kW]
 $I \dots$ [A]
 $i [-]$
 $c [-]$

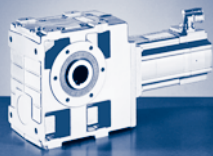

GSS [Nm]

GSS□□-□S (MCS)

$M_{2GN} \leq 720 \text{ Nm}$

GSS06-2S				06FC41	06IC41	09DC41	09FC38	09HC41	09LC41	12DC20	12DC41	12HC15	12HC30	
				...500	...500	...500	...500	...500	...500	...500	...500	...500	...500	
i	M_{2GN}	J_G	M_1	1.20	1.50	2.30	3.10	3.80	4.50	5.50	4.30	10.00	8.00	
			n_1	4050	4050	4050	3750	4050	4050	1950	4050	1500	3000	
			I_{M230}	2.9	3.2	4.6	5.0	6.8	8.4	5.2	8.8	7.6	10.5	
			I_{M400}	1.5	1.6	2.3	2.5	3.4	4.2	2.6	4.5	3.8		
			P_N	0.51	0.64	1.00	1.20	1.60	1.90	1.10	1.80	1.60	2.50	
			J_M	0.25	0.33	1.13	1.53	1.93	2.83	4.12	4.12	7.42	7.42	
87.833	684	0.44	M_2		103									
			c		5.6									
			$n_{2 \text{ Eck}}$		46									
			$n_{2 \text{ th}}$		46									
87.833	720	0.44	M_2			162	220	272	323	389	308	702	577	
			c			3.7	2.7	2.2	1.9	1.8	2.0	1.0	1.2	
			$n_{2 \text{ Eck}}$			46	43	46	46	46	22	46	17	34
			$n_{2 \text{ th}}$			46	43	46	46	46	22	46	17	34
99.167	720	0.42	M_2		116	181	247	304	362	434	345		645	
			c		5.1	3.3	2.5	2.0	1.7	1.7	1.8		1.1	
			$n_{2 \text{ Eck}}$		41	41	38	41	41	20	41		30	
			$n_{2 \text{ th}}$		41	41	38	41	41	20	41		30	
113.667	699	0.28	M_2	105	134									
			c	5.9	4.8									
			$n_{2 \text{ Eck}}$	36	36									
			$n_{2 \text{ th}}$	36	36									
113.667	720	0.28	M_2			209	285	351	417					
			c			3.1	2.3	1.9	1.6					
			$n_{2 \text{ Eck}}$			36	33	36	36					
			$n_{2 \text{ th}}$			36	33	36	36					
128.333	720	0.26	M_2	118	150	234	319	393	466					
			c	5.4	4.3	2.8	2.1	1.7	1.4					
			$n_{2 \text{ Eck}}$	32	32	32	29	32	32					
			$n_{2 \text{ th}}$	32	32	32	29	32	32					
137.950	700	0.20	M_2	128	162									
			c	5.3	4.2									
			$n_{2 \text{ Eck}}$	29	29									
			$n_{2 \text{ th}}$	29	29									
137.950	720	0.20	M_2			253	345	424	504					
			c			2.7	2.0	1.7	1.4					
			$n_{2 \text{ Eck}}$			29	27	29	29					
			$n_{2 \text{ th}}$			29	27	29	29					
155.750	720	0.19	M_2	144	182	283	385	474	563					
			c	4.8	3.8	2.5	1.8	1.5	1.3					
			$n_{2 \text{ Eck}}$	26	26	26	24	26	26					
			$n_{2 \text{ th}}$	26	26	26	24	26	26					
174.375	681	0.13	M_2	162	205									
			c	4.2	3.4									
			$n_{2 \text{ Eck}}$	23	23									
			$n_{2 \text{ th}}$	23	23									
196.875	720	0.12	M_2	182	229									
			c	3.8	3.0									
			$n_{2 \text{ Eck}}$	21	21									
			$n_{2 \text{ th}}$	21	21									

M ... [Nm]
n ... [r/min]
J ... [kgcm²]

P ... [kW]
I ... [A]
i [-]
c [-]

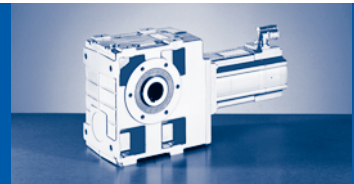

$M_{2GN} \leq 720 \text{ Nm}$

12HC35	12LC20	12LC41	14DC15	14DC36	14HC15	14HC32	14LC15	14LC32	14PC14	14PC32	GSS06-2S			
...500	...500	...500	...500	...500	...500	...500	...500	...500	...500	...500	M_1	J_G	M_{2GN}	i
7.50	13.50	11.00	9.20	7.50	16.00	14.00	23.00	17.20	30.00	21.00	n_1			
3525	1950	4050	1500	3600	1500	3225	1500	3225	1350	3225	I_{M230}			
	11.8										I_{M400}			
5.7	5.9	10.2	4.5	7.5	6.6	11.9	9.7	15.0	10.8	15.6	P_N			
2.80	2.80	4.70	1.45	2.80	2.50	4.70	3.60	5.80	4.20	7.10	J_M			
7.42	10.72	10.72	8.22	8.22	14.32	14.32	23.44	23.44	34.74	34.82	M_2			
											c	0.44	684	87.833
											n_2			
											Eck			
											n_2			
											th			
543											M_2	0.44	720	87.833
1.2											c			
40											n_2			
40											Eck			
											n_2			
											th			
607											M_2	0.42	720	99.167
1.1											c			
36											n_2			
36											Eck			
											n_2			
											th			
											M_2	0.28	699	113.667
											c			
											n_2			
											Eck			
											n_2			
											th			
											M_2	0.28	720	113.667
											c			
											n_2			
											Eck			
											n_2			
											th			
											M_2	0.26	720	128.333
											c			
											n_2			
											Eck			
											n_2			
											th			
											M_2	0.20	700	137.950
											c			
											n_2			
											Eck			
											n_2			
											th			
											M_2	0.20	720	137.950
											c			
											n_2			
											Eck			
											n_2			
											th			
											M_2	0.19	720	155.750
											c			
											n_2			
											Eck			
											n_2			
											th			
											M_2	0.13	681	174.375
											c			
											n_2			
											Eck			
											n_2			
											th			
											M_2	0.12	720	196.875
											c			
											n_2			
											Eck			
											n_2			
											th			

M ... [Nm]
n ... [r/min]
J ... [kgcm²]

P ... [kW]
I ... [A]
i [-]
c [-]

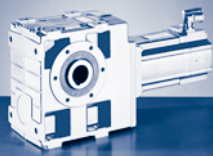

GSS [Nm]

GSS□□-□S (MCS)

$M_{2GN} \leq 720 \text{ Nm}$

GSS06-3S				06CC41	06FC41	06IC41	09DC41	09FC38	09HC41
				...500	...500	...500	...500	...500	...500
i	M_{2GN}	J_G	M_1	0.60	1.20	1.50	2.30	3.10	3.80
			n_1	4050	4050	4050	4050	3750	4050
			I_{M230}	2.6	2.9	3.2	4.6	5.0	6.8
			I_{M400}	1.3	1.5	1.6	2.3	2.5	3.4
			P_N	0.25	0.51	0.64	1.00	1.20	1.60
			J_M	0.17	0.25	0.33	1.13	1.53	1.93
126.531	720	0.31	M_2		116	146	226	306	376
			c		3.2	2.5	1.7	1.2	1.0
			$n_{2 \text{ Eck}}$		32	32	32	30	32
			$n_{2 \text{ th}}$		32	32	32	30	32
142.857	720	0.30	M_2		129	162	252	341	419
			c		3.2	2.5	1.7	1.2	1.0
			$n_{2 \text{ Eck}}$		28	28	28	26	28
			$n_{2 \text{ th}}$		28	28	28	26	28
155.000	720	0.27	M_2	68	141	178	275	372	
			c	5.6	2.8	2.3	1.5	1.1	
			$n_{2 \text{ Eck}}$	26	26	26	26	24	
			$n_{2 \text{ th}}$	26	26	26	26	24	
175.000	720	0.26	M_2	76	157	197	306	414	
			c	5.6	2.8	2.3	1.5	1.1	
			$n_{2 \text{ Eck}}$	23	23	23	23	21	
			$n_{2 \text{ th}}$	23	23	23	23	21	
194.857	720	0.14	M_2	85	176	222			
			c	4.7	2.4	1.9			
			$n_{2 \text{ Eck}}$	21	21	21			
			$n_{2 \text{ th}}$	21	21	21			
220.000	720	0.14	M_2	95	196	246			
			c	4.7	2.4	1.9			
			$n_{2 \text{ Eck}}$	18	18	18			
			$n_{2 \text{ th}}$	18	18	18			
238.700	720	0.13	M_2	104	214	269			
			c	4.2	2.1	1.7			
			$n_{2 \text{ Eck}}$	17	17	17			
			$n_{2 \text{ th}}$	17	17	17			
269.500	720	0.12	M_2	116	238	299			
			c	4.2	2.1	1.7			
			$n_{2 \text{ Eck}}$	15	15	15			
			$n_{2 \text{ th}}$	15	15	15			
310.689	720	0.11	M_2	136	277	348			
			c	2.8	1.4	1.1			
			$n_{2 \text{ Eck}}$	13	13	13			
			$n_{2 \text{ th}}$	13	13	13			
350.778	720	0.11	M_2	151	307	385			
			c	2.8	1.4	1.1			
			$n_{2 \text{ Eck}}$	12	12	12			
			$n_{2 \text{ th}}$	12	12	12			
386.467	720	0.10	M_2	168	341				
			c	2.4	1.2				
			$n_{2 \text{ Eck}}$	11	11				
			$n_{2 \text{ th}}$	10	10				
436.333	720	0.10	M_2	186	379				
			c	2.4	1.2				
			$n_{2 \text{ Eck}}$	9	9				
			$n_{2 \text{ th}}$	9	9				
497.722	720	0.07	M_2	214	434				
			c	2.0	1.0				
			$n_{2 \text{ Eck}}$	8	8				
			$n_{2 \text{ th}}$	8	8				

$M \dots$ [Nm]
 $n \dots$ [r/min]
 $J \dots$ [kgcm²]

$P \dots$ [kW]
 $I \dots$ [A]
 $i \dots$ [-]
 $c \dots$ [-]

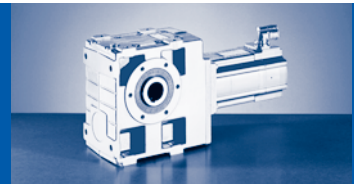

$M_{2GN} \leq 720 \text{ Nm}$

GSS06-3S				06CC41	06FC41	06IC41	09DC41	09FC38	09HC41
				...500	...500	...500	...500	...500	...500
i	M_{2GN}	J_G	M_1	0.60	1.20	1.50	2.30	3.10	3.80
			n_1	4050	4050	4050	4050	3750	4050
			I_{M230}	2.6	2.9	3.2	4.6	5.0	6.8
			I_{M400}	1.3	1.5	1.6	2.3	2.5	3.4
			P_N	0.25	0.51	0.64	1.00	1.20	1.60
			J_M	0.17	0.25	0.33	1.13	1.53	1.93
561.944	720	0.07	M_2	238	482				
			c	2.0	1.0				
			$n_{2 \text{ Eck}}$	7	7				
			$n_{2 \text{ th}}$	7	7				

M ... [Nm]
n ... [r/min]
J ... [kgcm²]

P ... [kW]
I ... [A]
i [-]
c [-]

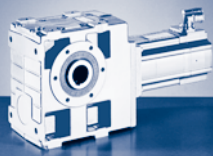

GSS [Nm]

GSS□□-□S (MCS)

$M_{2GN} \leq 1250 \text{ Nm}$

GSS07-2S				09DC41	09FC38	09HC41	09LC41	12DC20	12DC41	12HC15	12HC30	12HC35	12LC20	12LC41	14DC15
				...S00	...S00	...S00	...S00	...S00	...S00	...S00	...S00	...S00	...S00	...S00	...S00
i	M_{2GN}	J_G	M_1	2.30	3.10	3.80	4.50	5.50	4.30	10.00	8.00	7.50	13.50	11.00	9.20
			n_1	4050	3750	4050	4050	1950	4050	1500	3000	3525	1950	4050	1500
			I_{M230}	4.6	5.0	6.8	8.4	5.2	8.8	7.6	10.5		11.8		
			I_{M400}	2.3	2.5	3.4	4.2	2.6	4.5	3.8		5.7	5.9	10.2	4.5
			P_N	1.00	1.20	1.60	1.90	1.10	1.80	1.60	2.50	2.80	2.80	4.70	1.45
			J_M	1.13	1.53	1.93	2.83	4.12	4.12	7.42	7.42	7.42	10.72	10.72	8.22
5.862	539	21.36	M_2 c n_{2Eck} n_{2th}												
8.125	685	12.75	M_2 c n_{2Eck} n_{2th}												
9.086	628	17.44	M_2 c n_{2Eck} n_{2th}												
10.000	468	9.14	M_2 c n_{2Eck} n_{2th}							89 5.0 150 150			122 3.7 195 195	99 3.8 405 405	
10.000	734	9.14	M_2 c n_{2Eck} n_{2th}												
10.000	797	9.14	M_2 c n_{2Eck} n_{2th}												
11.200	496	7.50	M_2 c n_{2Eck} n_{2th}							100 4.8 134 134	79 6.0 268 268	74 5.9 315 315	137 3.5 174 174	111 3.7 362 362	
11.200	771	7.50	M_2 c n_{2Eck} n_{2th}												
11.200	866	7.50	M_2 c n_{2Eck} n_{2th}												
12.594	799	10.71	M_2 c n_{2Eck} n_{2th}												
14.286	533	4.84	M_2 c n_{2Eck} n_{2th}							129 4.0 105 105	101 5.0 210 210	95 5.4 247 247	175 3.0 137 137	142 3.4 284 284	
14.286	737	4.84	M_2 c n_{2Eck} n_{2th}												
15.500	704	7.79	M_2 c n_{2Eck} n_{2th}							134 5.0 97 97	107 5.0 194 194	101 4.7 227 227	183 3.7 126 126	151 3.0 261 261	

$M \dots$ [Nm]
 $n \dots$ [r/min]
 $J \dots$ [kgcm²]

$P \dots$ [kW]
 $I \dots$ [A]
 $i \dots$ [-]
 $c \dots$ [-]

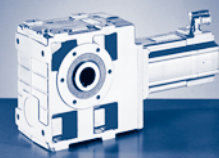

$M_{2GN} \leq 1250 \text{ Nm}$

14DC36	14HC15	14HC32	14LC15	14LC32	14PC14	14PC32	19FC14	19FC30	19JC14	19JC30	19PC14	19PC30	GSS07-2S			
...500	...500	...500	...500	...500	...500	...500	...500	...500	...500	...500	...500	...500	M_1	J_G	M_{2GN}	i
7.50	16.00	14.00	23.00	17.20	30.00	21.00	27.00	21.00	40.00	29.00	51.00	32.00	n_1			
3600	1500	3225	1500	3225	1350	3225	1425	3000	1425	3000	1350	3000	I_{M230}			
													I_{M400}			
7.5	6.6	11.9	9.7	15.0	10.8	15.6	8.6	14.0	12.3	18.5	14.3	19.0	P_N			
2.80	2.50	4.70	3.60	5.80	4.20	7.10	4.00	6.60	6.00	9.10	7.20	10.00	J_M			
8.22	14.32	14.32	23.44	23.44	34.74	34.82	65.12	65.04	105.04	105.12	160.12	160.04	M_2			
		73	120	91	159	111	142	111	214	155	274	171	c	21.36	539	5.862
		3.8	4.3	3.1	3.3	2.5	3.7	2.9	2.5	2.1	2.0	1.9	n_2 Eck			
		550	256	550	230	550	243	512	243	512	230	512	n_2 th			
		550	256	550	230	550	243	377	243	377	230	377				
53	115	102	168	126	221	155	198	155	298	216	381	238	M_2	12.75	685	8.125
5.9	5.7	3.4	4.0	2.8	3.0	2.3	3.4	2.6	2.3	1.9	1.8	1.7	c			
443	185	397	185	397	166	397	175	369	175	369	166	369	n_2 Eck			
442	185	397	185	397	166	397	175	272	175	272	166	272	n_2 th			
58	126	112	184	139	242	170	217	170	325	236	417	261	M_2	17.44	628	9.086
5.7	4.8	3.3	3.3	2.7	2.6	2.2	2.8	2.4	1.9	1.7	1.5	1.6	c			
396	165	355	165	355	149	355	157	330	157	330	149	330	n_2 Eck			
395	165	355	165	355	149	355	157	243	157	243	149	243	n_2 th			
													M_2	9.14	468	10.000
													c			
													n_2 Eck			
													n_2 th			
66	142	126	208	156	274	192							M_2	9.14	734	10.000
5.5	4.9	3.3	3.4	2.6	2.6	2.2							c			
360	150	323	150	323	135	323							n_2 Eck			
359	150	323	150	323	135	323							n_2 th			
							245	191	367	266	470	294	M_2	9.14	797	10.000
							3.2	2.5	2.2	1.8	1.7	1.6	c			
							143	300	143	300	135	300	n_2 Eck			
							143	221	143	221	135	221	n_2 th			
													M_2	7.50	496	11.200
													c			
													n_2 Eck			
													n_2 th			
74	160	142	234	175	307	215							M_2	7.50	771	11.200
5.4	4.6	3.2	3.2	2.6	2.5	2.1							c			
321	134	288	134	288	121	288							n_2 Eck			
321	134	288	134	288	121	288							n_2 th			
							275	215	411	298	527	330	M_2	7.50	866	11.200
							3.1	2.4	2.1	1.7	1.6	1.6	c			
							127	268	127	268	121	268	n_2 Eck			
							127	197	127	197	121	197	n_2 th			
82	175	156	256	193	336	237	302	237	451	329	578	363	M_2	10.71	799	12.594
4.9	4.4	2.8	3.1	2.3	2.3	1.9	2.6	2.1	1.8	1.5	1.4	1.4	c			
286	119	256	119	256	107	256	113	238	113	238	107	238	n_2 Eck			
285	119	256	119	256	107	256	113	176	113	176	107	176	n_2 th			
													M_2	4.84	533	14.286
													c			
													n_2 Eck			
													n_2 th			
95	207	181	301	224	395	275							M_2	4.84	737	14.286
5.0	3.5	2.9	2.4	2.4	1.9	2.0							c			
252	105	226	105	226	95	226							n_2 Eck			
251	105	226	105	226	95	226							n_2 th			
													M_2	7.79	704	15.500
													c			
													n_2 Eck			
													n_2 th			

M ... [Nm]
n ... [r/min]
J ... [kgcm²]

P ... [kW]
I ... [A]
i [-]
c [-]

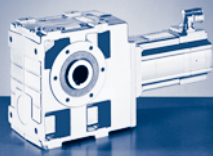

GSS [Nm]

GSS□□-□S (MCS)

$M_{2GN} \leq 1250 \text{ Nm}$

GSS07-2S				09DC41	09FC38	09HC41	09LC41	12DC20	12DC41	12HC15	12HC30	12HC35	12LC20	12LC41	14DC15
				...S00	...S00	...S00	...S00	...S00	...S00	...S00	...S00	...S00	...S00	...S00	...S00
i	M_{2GN}	J_G	M_1	2.30	3.10	3.80	4.50	5.50	4.30	10.00	8.00	7.50	13.50	11.00	9.20
			n_1	4050	3750	4050	4050	1950	4050	1500	3000	3525	1950	4050	1500
			I_{M230}	4.6	5.0	6.8	8.4	5.2	8.8	7.6	10.5		11.8		
			I_{M400}	2.3	2.5	3.4	4.2	2.6	4.5	3.8		5.7	5.9	10.2	4.5
			P_N	1.00	1.20	1.60	1.90	1.10	1.80	1.60	2.50	2.80	2.80	4.70	1.45
			J_M	1.13	1.53	1.93	2.83	4.12	4.12	7.42	7.42	7.42	10.72	10.72	8.22
15.500	931	7.79	M_2 c $n_{2 \text{ Eck}}$ $n_{2 \text{ th}}$												
17.360	746	6.42	M_2 c $n_{2 \text{ Eck}}$ $n_{2 \text{ th}}$							150 4.8 86 86	120 4.8 173 173	113 4.5 203 203	206 3.5 112 112	169 2.9 233 233	
17.360	1012	6.42	M_2 c $n_{2 \text{ Eck}}$ $n_{2 \text{ th}}$												
20.517	764	13.58	M_2 c $n_{2 \text{ Eck}}$ $n_{2 \text{ th}}$												152 4.8 73 73
22.143	797	4.18	M_2 c $n_{2 \text{ Eck}}$ $n_{2 \text{ th}}$							192 4.0 68 68	154 4.5 136 135	145 4.2 159 159	264 3.0 88 88	216 2.6 183 183	
22.143	1103	4.18	M_2 c $n_{2 \text{ Eck}}$ $n_{2 \text{ th}}$												
25.188	913	9.59	M_2 c $n_{2 \text{ Eck}}$ $n_{2 \text{ th}}$												189 4.6 60 60
27.125	837	3.13	M_2 c $n_{2 \text{ Eck}}$ $n_{2 \text{ th}}$							236 3.5 55 55	189 4.3 111 111	178 4.0 130 130	324 2.6 72 72	265 2.5 149 149	
27.125	1250	3.13	M_2 c $n_{2 \text{ Eck}}$ $n_{2 \text{ th}}$												212 5.6 55 55
31.000	1065	7.05	M_2 c $n_{2 \text{ Eck}}$ $n_{2 \text{ th}}$					137 5.7 63 63	109 4.7 131 131	254 4.1 48 48	206 3.0 97 97	194 2.9 114 114	351 2.3 63 63	288 1.8 131 131	233 4.4 48 48
35.306	676	1.96	M_2 c $n_{2 \text{ Eck}}$ $n_{2 \text{ th}}$			115 5.7 115 115	137 4.8 115 115								
35.306	870	1.96	M_2 c $n_{2 \text{ Eck}}$ $n_{2 \text{ th}}$					166 5.0 55 55	130 6.0 115 115	309 2.8 43 42	248 3.5 85 85	232 3.7 100 100	422 2.1 55 55	345 2.3 115 115	
35.306	1250	1.96	M_2 c $n_{2 \text{ Eck}}$ $n_{2 \text{ th}}$												279 4.3 43 42

M ... [Nm]
n ... [r/min]
J ... [kgcm²]

P ... [kW]
I ... [A]
i [-]
c [-]

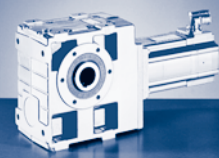

$M_{2GN} \leq 1250 \text{ Nm}$

14DC36	14HC15	14HC32	14LC15	14LC32	14PC14	14PC32	19FC14	19FC30	19JC14	19JC30	19PC14	19PC30	GSS07-2S			
...500	...500	...500	...500	...500	...500	...500	...500	...500	...500	...500	...500	...500	M_1	J_G	M_{2GN}	i
7.50	16.00	14.00	23.00	17.20	30.00	21.00	27.00	21.00	40.00	29.00	51.00	32.00	n_1			
3600	1500	3225	1500	3225	1350	3225	1425	3000	1425	3000	1350	3000	I_{M230}			
													I_{M400}			
7.5	6.6	11.9	9.7	15.0	10.8	15.6	8.6	14.0	12.3	18.5	14.3	19.0	P_N			
2.80	2.50	4.70	3.60	5.80	4.20	7.10	4.00	6.60	6.00	9.10	7.20	10.00	J_M			
8.22	14.32	14.32	23.44	23.44	34.74	34.82	65.12	65.04	105.04	105.12	160.12	160.04	M_2			
101	216	193	315	238	414	292	372	292	555	405	711	447	c	7.79	931	15.500
4.4	4.2	2.5	2.9	2.1	2.2	1.7	2.5	1.9	1.7	1.4	1.3	1.3	n_{2Eck}			
232	97	208	97	208	87	208	92	194	92	194	87	194	n_{2th}			
232	97	208	97	208	87	208	92	143	92	143	87	143	M_2			
													c	6.42	746	17.360
													n_{2Eck}			
													n_{2th}			
114	242	216	353	267	463	328	416	327	622	454	796	501	M_2			
4.2	4.0	2.4	2.8	2.0	2.2	1.6	2.4	1.8	1.6	1.3	1.3	1.2	c	6.42	1012	17.360
207	86	186	86	186	78	186	82	173	82	173	78	173	n_{2Eck}			
207	86	186	86	186	78	186	82	127	82	127	78	127	n_{2th}			
126	272	240	394	296	517	362	465	362	693				M_2			
3.3	2.8	1.9	1.9	1.5	1.5	1.3	1.6	1.4	1.1				c	13.58	764	20.517
176	73	157	73	157	66	157	70	146	70				n_{2Eck}			
175	73	157	73	157	66	157	69	108	69				n_{2th}			
													M_2			
													c	4.18	797	22.143
													n_{2Eck}			
													n_{2th}			
145	309	276	450	341	591	418							M_2			
3.9	3.5	2.3	2.4	1.8	1.9	1.5							c	4.18	1103	22.143
163	68	146	68	146	61	146							n_{2Eck}			
162	68	146	68	146	61	146							n_{2th}			
157	336	298	488	367	639	450	574	449	856				M_2			
3.0	2.7	1.7	1.9	1.4	1.4	1.1	1.6	1.2	1.1				c	9.59	913	25.188
143	60	128	60	128	54	128	57	119	57				n_{2Eck}			
143	60	128	60	128	54	128	57	88	57				n_{2th}			
													M_2			
													c	3.13	837	27.125
													n_{2Eck}			
													n_{2th}			
178	379	339	551	418	723	512							M_2			
3.7	3.2	2.2	2.2	1.8	1.7	1.4							c	3.13	1250	27.125
133	55	119	55	119	50	119							n_{2Eck}			
132	55	119	55	119	50	119							n_{2th}			
194	414	367	600	453	786	555	706	554	1052				M_2			
2.7	2.5	1.5	1.8	1.3	1.4	1.0	1.5	1.2	1.0				c	7.05	1065	31.000
116	48	104	48	104	44	104	46	97	46				n_{2Eck}			
116	48	104	48	104	44	104	46	71	46				n_{2th}			
													M_2			
													c	1.96	676	35.306
													n_{2Eck}			
													n_{2th}			
													M_2			
													c	1.96	870	35.306
													n_{2Eck}			
													n_{2th}			
233	495	441	718	544	941	667							M_2			
3.4	2.5	2.0	1.7	1.6	1.3	1.3							c	1.96	1250	35.306
102	43	91	43	91	38	91							n_{2Eck}			
102	42	91	42	91	38	91							n_{2th}			

M ... [Nm]
n ... [r/min]
J ... [kgcm²]

P ... [kW]
I ... [A]
i [-]
c [-]

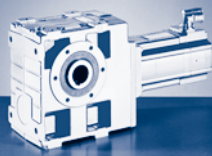

GSS [Nm]

GSS□□-□S (MCS)

$M_{2GN} \leq 1250 \text{ Nm}$

GSS07-2S				09DC41	09FC38	09HC41	09LC41	12DC20	12DC41	12HC15	12HC30	12HC35	12LC20	12LC41	14DC15
				...S00	...S00	...S00	...S00	...S00	...S00	...S00	...S00	...S00	...S00	...S00	...S00
i	M_{2GN}	J_G	M_1	2.30	3.10	3.80	4.50	5.50	4.30	10.00	8.00	7.50	13.50	11.00	9.20
			n_1	4050	3750	4050	4050	1950	4050	1500	3000	3525	1950	4050	1500
			I_{M230}	4.6	5.0	6.8	8.4	5.2	8.8	7.6	10.5		11.8		
			I_{M400}	2.3	2.5	3.4	4.2	2.6	4.5	3.8		5.7	5.9	10.2	4.5
			P_N	1.00	1.20	1.60	1.90	1.10	1.80	1.60	2.50	2.80	2.80	4.70	1.45
			J_M	1.13	1.53	1.93	2.83	4.12	4.12	7.42	7.42	7.42	10.72	10.72	8.22
39.200	1175	5.37	M_2					172	137	319	260	244	440	362	292
			c				5.3	4.2	3.6	2.8	2.6	2.2	1.6	3.9	
			$n_{2 \text{ Eck}}$				50	103	38	77	90	50	103	38	
			$n_{2 \text{ th}}$				50	103	38	77	90	50	103	38	
43.271	706	1.43	M_2		114	142	169								
			c		5.9	4.8	4.1								
			$n_{2 \text{ Eck}}$		87	94	94								
			$n_{2 \text{ th}}$		87	94	94								
43.271	908	1.43	M_2					205	159	378	304	285	518	423	
			c				4.3	5.5	2.4	3.0	3.2	1.8	2.2		
			$n_{2 \text{ Eck}}$				45	94	35	69	82	45	94		
			$n_{2 \text{ th}}$				45	94	35	69	81	45	94		
43.271	1250	1.43	M_2												343
			c												3.5
			$n_{2 \text{ Eck}}$												35
			$n_{2 \text{ th}}$												35
50.000	1250	3.53	M_2		124	154	184	220	176	407	331	311	560	462	374
			c		5.4	4.4	3.7	4.9	3.9	3.0	2.6	2.4	2.0	1.5	3.3
			$n_{2 \text{ Eck}}$		75	81	81	39	81	30	60	71	39	81	30
			$n_{2 \text{ th}}$		75	81	81	39	81	30	60	71	39	81	30
54.250	1250	2.89	M_2					241	192	446	362	341	613	505	409
			c				4.8	3.9	2.8	2.6	2.4	1.9	1.5	3.0	
			$n_{2 \text{ Eck}}$				36	75	28	55	65	36	75	28	
			$n_{2 \text{ th}}$				36	75	28	55	65	36	75	28	
61.250	1250	2.70	M_2					271	215	500	405	381	686	565	459
			c				4.3	3.7	2.5	2.5	2.3	1.8	1.4	2.7	
			$n_{2 \text{ Eck}}$				32	66	25	49	58	32	66	25	
			$n_{2 \text{ th}}$				32	66	24	49	58	32	66	24	
70.611	1250	1.81	M_2		177	220	262	316	250	579	471	443	796	656	531
			c		5.0	4.1	3.5	3.8	3.6	2.1	2.4	2.3	1.6	1.4	2.3
			$n_{2 \text{ Eck}}$		53	57	57	28	57	21	43	50	28	57	21
			$n_{2 \text{ th}}$		53	57	57	28	57	21	42	50	28	57	21
79.722	1250	1.70	M_2		199	246	293	354	280	649	527	496	891	734	596
			c		4.8	3.9	3.3	3.4	3.4	1.9	2.2	2.2	1.4	1.3	2.1
			$n_{2 \text{ Eck}}$		47	51	51	25	51	19	38	44	25	51	19
			$n_{2 \text{ th}}$		47	51	51	24	51	19	38	44	24	51	19
86.542	1250	1.34	M_2		217	269	321	387	306	707	577	543	972	803	649
			c		4.8	3.9	3.3	3.2	3.5	1.8	2.1	2.1	1.3	1.4	1.9
			$n_{2 \text{ Eck}}$		43	47	47	23	47	17	35	41	23	47	17
			$n_{2 \text{ th}}$		43	47	47	23	47	17	35	41	23	47	17
97.708	1250	1.26	M_2		244	302	360	435	343	791	646	608	1089	898	727
			c		4.5	3.6	3.1	2.8	3.2	1.6	1.9	1.9	1.2	1.3	1.7
			$n_{2 \text{ Eck}}$		38	42	42	20	42	15	31	36	20	42	15
			$n_{2 \text{ th}}$		38	41	41	20	41	15	31	36	20	41	15
113.667	1250	0.83	M_2	208	286	354	422	508	402	924	756	712		1051	
			c	5.6	4.1	3.4	2.9	2.4	3.0	1.4	1.6	1.7		1.2	
			$n_{2 \text{ Eck}}$	36	33	36	36	17	36	13	26	31		36	
			$n_{2 \text{ th}}$	36	33	36	36	17	36	13	26	31		36	
128.333	1250	0.79	M_2	234	321	397	472	569	451	1030	847	797		1176	
			c	5.1	3.8	3.1	2.6	2.2	2.7	1.2	1.5	1.6		1.1	
			$n_{2 \text{ Eck}}$	32	29	32	32	15	32	12	23	28		32	
			$n_{2 \text{ th}}$	32	29	32	32	15	32	12	23	27		32	

$M \dots$ [Nm]
 $n \dots$ [r/min]
 $J \dots$ [kgcm²]

$P \dots$ [kW]
 $I \dots$ [A]
 $i \dots$ [-]
 $c \dots$ [-]

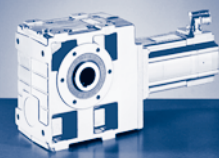

$M_{2GN} \leq 1250 \text{ Nm}$

14DC36	14HC15	14HC32	14LC15	14LC32	14PC14	14PC32	19FC14	19FC30	19JC14	19JC30	19PC14	19PC30	GSS07-2S			
...500	...500	...500	...500	...500	...500	...500	...500	...500	...500	...500	...500	...500	M_1	J_G	M_{2GN}	i
7.50	16.00	14.00	23.00	17.20	30.00	21.00	27.00	21.00	40.00	29.00	51.00	32.00	n_1			
3600	1500	3225	1500	3225	1350	3225	1425	3000	1425	3000	1350	3000	I_{M230}			
													I_{M400}			
7.5	6.6	11.9	9.7	15.0	10.8	15.6	8.6	14.0	12.3	18.5	14.3	19.0	P_N			
2.80	2.50	4.70	3.60	5.80	4.20	7.10	4.00	6.60	6.00	9.10	7.20	10.00	J_M			
8.22	14.32	14.32	23.44	23.44	34.74	34.82	65.12	65.04	105.04	105.12	160.12	160.04	M_2			
245	518	462	751	569	984		884	695					c	5.37	1175	39.200
2.4	2.2	1.4	1.6	1.1	1.2		1.3	1.1					$n_{2 \text{ Eck}}$			
92	38	82	38	82	34		36	77					$n_{2 \text{ th}}$			
92	38	82	38	82	34		36	56					M_2			
													c	1.43	706	43.271
													$n_{2 \text{ Eck}}$			
													$n_{2 \text{ th}}$			
													M_2			
													c	1.43	908	43.271
													$n_{2 \text{ Eck}}$			
													$n_{2 \text{ th}}$			
285	607	540	879	666	1150	816							M_2			
3.3	2.0	1.9	1.4	1.6	1.1	1.3							c	1.43	1250	43.271
83	35	75	35	75	31	75							$n_{2 \text{ Eck}}$			
83	35	75	35	75	31	75							$n_{2 \text{ th}}$			
312	661	589	956	726									M_2			
2.2	1.9	1.3	1.3	1.1									c	3.53	1250	50.000
72	30	65	30	65									$n_{2 \text{ Eck}}$			
72	30	65	30	65									$n_{2 \text{ th}}$			
342	722	645	1044	794									M_2			
2.2	1.7	1.3	1.2	1.1									c	2.89	1250	54.250
66	28	60	28	60									$n_{2 \text{ Eck}}$			
66	28	59	28	59									$n_{2 \text{ th}}$			
382	809	721	1169	888									M_2			
2.1	1.5	1.2	1.1	1.0									c	2.70	1250	61.250
59	25	53	25	53									$n_{2 \text{ Eck}}$			
59	24	53	24	53									$n_{2 \text{ th}}$			
444	935	837											M_2			
2.1	1.3	1.2											c	1.81	1250	70.611
51	21	46											$n_{2 \text{ Eck}}$			
51	21	46											$n_{2 \text{ th}}$			
497	1047	936											M_2			
2.0	1.2	1.2											c	1.70	1250	79.722
45	19	41											$n_{2 \text{ Eck}}$			
45	19	40											$n_{2 \text{ th}}$			
544	1140	1025											M_2			
2.0	1.1	1.1											c	1.34	1250	86.542
42	17	37											$n_{2 \text{ Eck}}$			
41	17	37											$n_{2 \text{ th}}$			
608		1146											M_2			
1.9		1.0											c	1.26	1250	97.708
37		33											$n_{2 \text{ Eck}}$			
37		33											$n_{2 \text{ th}}$			
													M_2			
													c	0.83	1250	113.667
													$n_{2 \text{ Eck}}$			
													$n_{2 \text{ th}}$			
													M_2			
													c	0.79	1250	128.333
													$n_{2 \text{ Eck}}$			
													$n_{2 \text{ th}}$			

M ... [Nm]
n ... [r/min]
J ... [kgcm²]

P ... [kW]
I ... [A]
i [-]
c [-]

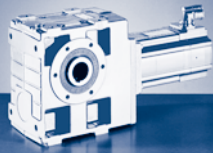

GSS [Nm]

GSS□□-□S (MCS)

$M_{2GN} \leq 1250 \text{ Nm}$

GSS07-2S				09DC41	09FC38	09HC41	09LC41	12DC20	12DC41	12HC15	12HC30	12HC35	12LC20	12LC41	14DC15
				...S00	...S00	...S00	...S00	...S00	...S00	...S00	...S00	...S00	...S00	...S00	...S00
i	M_{2GN}	J_G	M_1	2.30	3.10	3.80	4.50	5.50	4.30	10.00	8.00	7.50	13.50	11.00	9.20
			n_1	4050	3750	4050	4050	1950	4050	1500	3000	3525	1950	4050	1500
			I_{M230}	4.6	5.0	6.8	8.4	5.2	8.8	7.6	10.5		11.8		
			I_{M400}	2.3	2.5	3.4	4.2	2.6	4.5	3.8		5.7	5.9	10.2	4.5
			P_N	1.00	1.20	1.60	1.90	1.10	1.80	1.60	2.50	2.80	2.80	4.70	1.45
			J_M	1.13	1.53	1.93	2.83	4.12	4.12	7.42	7.42	7.42	10.72	10.72	8.22
137.950	1250	0.61	M_2	254	348	429	511	615	488	1116	914	862			
			c	4.7	3.5	2.8	2.4	2.0	2.5	1.1	1.4	1.4			
			$n_{2 \text{ Eck}}$	29	27	29	29	14	29	11	22	26			
			$n_{2 \text{ th}}$	29	27	29	29	14	29	11	22	26			
155.750	1250	0.58	M_2	286	390	482	573	687	547	1241	1024	965			
			c	4.2	3.1	2.5	2.1	1.8	2.2	1.0	1.2	1.3			
			$n_{2 \text{ Eck}}$	26	24	26	26	13	26	10	19	23			
			$n_{2 \text{ th}}$	26	24	26	26	13	26	10	19	23			
174.375	1250	0.39	M_2	322	439	542	644								
			c	3.7	2.8	2.3	1.9								
			$n_{2 \text{ Eck}}$	23	22	23	23								
			$n_{2 \text{ th}}$	23	22	23	23								
196.875	1250	0.37	M_2	362	493	607	722								
			c	3.3	2.5	2.0	1.7								
			$n_{2 \text{ Eck}}$	21	19	21	21								
			$n_{2 \text{ th}}$	21	19	21	21								

M ... [Nm]
 n ... [r/min]
 J ... [kgcm²]

P ... [kW]
 I ... [A]
 i [-]
 c [-]

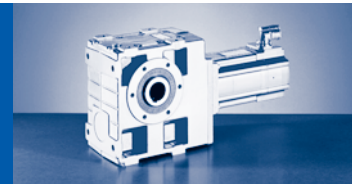

$M_{2GN} \leq 1250 \text{ Nm}$

14DC36	14HC15	14HC32	14LC15	14LC32	14PC14	14PC32	19FC14	19FC30	19JC14	19JC30	19PC14	19PC30	GSS07-2S			
...500	...500	...500	...500	...500	...500	...500	...500	...500	...500	...500	...500	...500	M_1	J_G	M_{2GN}	i
7.50	16.00	14.00	23.00	17.20	30.00	21.00	27.00	21.00	40.00	29.00	51.00	32.00	n_1			
3600	1500	3225	1500	3225	1350	3225	1425	3000	1425	3000	1350	3000	I_{M230}			
7.5	6.6	11.9	9.7	15.0	10.8	15.6	8.6	14.0	12.3	18.5	14.3	19.0	I_{M400}			
2.80	2.50	4.70	3.60	5.80	4.20	7.10	4.00	6.60	6.00	9.10	7.20	10.00	P_N			
8.22	14.32	14.32	23.44	23.44	34.74	34.82	65.12	65.04	105.04	105.12	160.12	160.04	J_M			
													M_2 c n_{2Eck} n_{2th}	0.61	1250	137.950
													M_2 c n_{2Eck} n_{2th}	0.58	1250	155.750
													M_2 c n_{2Eck} n_{2th}	0.39	1250	174.375
													M_2 c n_{2Eck} n_{2th}	0.37	1250	196.875

M ... [Nm]
n ... [r/min]
J ... [kgcm²]

P ... [kW]
I ... [A]
i [-]
c [-]

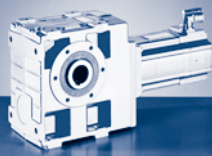

GSS [Nm]

GSS□□-□S (MCS)

$M_{2GN} \leq 1250 \text{ Nm}$

GSS07-3S				06CC41	06FC41	06IC41	09DC41	09FC38	09HC41	09LC41	12DC20	12DC41	12HC15	12HC30	12HC35	
				...S00	...S00	...S00	...S00	...S00	...S00	...S00	...S00	...S00	...S00	...S00	...S00	
i	M_{2GN}	J_G	M_1	0.60	1.20	1.50	2.30	3.10	3.80	4.50	5.50	4.30	10.00	8.00	7.50	
			n_1	4050	4050	4050	4050	3750	4050	4050	1950	4050	1500	3000	3525	
			I_{M230}	2.6	2.9	3.2	4.6	5.0	6.8	8.4	5.2	8.8	7.6	10.5		
			I_{M400}	1.3	1.5	1.6	2.3	2.5	3.4	4.2	2.6	4.5	3.8		5.7	
			P_N	0.25	0.51	0.64	1.00	1.20	1.60	1.90	1.10	1.80	1.60	2.50	2.80	
			J_M	0.17	0.25	0.33	1.13	1.53	1.93	2.83	4.12	4.12	7.42	7.42	7.42	
126.531	1250	0.86	M_2			145	227	309	381	453	539	432	979	802	761	
			c			5.1	3.3	2.5	2.0	1.7	2.3	1.8	1.3	1.6	1.0	
			$n_{2 \text{ Eck}}$			32	32	30	32	32	32	15	32	12	24	28
			$n_{2 \text{ th}}$			32	32	30	32	32	32	15	32	12	24	28
142.857	1250	0.82	M_2			162	254	346	426	507	603	484	1090	899		
			c			4.9	3.2	2.4	1.9	1.6	2.1	1.7	1.2	1.4		
			$n_{2 \text{ Eck}}$			28	28	26	28	28	14	28	11	21		
			$n_{2 \text{ th}}$			28	28	26	28	28	14	28	11	21		
155.000	1250	0.74	M_2			176	276	376	464	552	658	527	1195	978		
			c			4.9	3.2	2.4	1.9	1.6	1.9	1.7	1.1	1.3		
			$n_{2 \text{ Eck}}$			26	26	24	26	26	13	26	10	19		
			$n_{2 \text{ th}}$			26	26	24	26	26	13	26	10	19		
175.000	1250	0.72	M_2		156	198	310	422	520	618	734	590		1095		
			c		5.8	4.6	3.0	2.2	1.8	1.5	1.7	1.6		1.1		
			$n_{2 \text{ Eck}}$		23	23	23	21	23	23	11	23		17		
			$n_{2 \text{ th}}$		23	23	23	21	23	23	11	23		17		
201.746	1250	0.37	M_2		181	229	358	487	600	712						
			c		5.3	4.2	2.8	2.1	1.7	1.4						
			$n_{2 \text{ Eck}}$		20	20	20	19	20	20						
			$n_{2 \text{ th}}$		20	20	20	19	20	20						
227.778	1250	0.36	M_2		203	257	401	545	671	797						
			c		5.0	4.0	2.6	2.0	1.6	1.3						
			$n_{2 \text{ Eck}}$		18	18	18	17	18	18						
			$n_{2 \text{ th}}$		18	18	18	16	18	18						
247.139	1250	0.33	M_2		222	280	437	594	731	868						
			c		4.6	3.7	2.4	1.8	1.5	1.2						
			$n_{2 \text{ Eck}}$		16	16	16	15	16	16						
			$n_{2 \text{ th}}$		16	16	16	15	16	16						
279.028	1250	0.32	M_2		248	313	488	662	815	968						
			c		4.4	3.5	2.3	1.7	1.4	1.2						
			$n_{2 \text{ Eck}}$		15	15	15	13	15	15						
			$n_{2 \text{ th}}$		15	15	15	13	15	15						
321.673	1250	0.28	M_2		291	367	569	771	947							
			c		3.2	2.6	1.7	1.2	1.0							
			$n_{2 \text{ Eck}}$		13	13	13	12	13							
			$n_{2 \text{ th}}$		13	13	13	12	13							
363.179	1250	0.28	M_2		323	407	631	855	1051							
			c		3.2	2.6	1.7	1.2	1.0							
			$n_{2 \text{ Eck}}$		11	11	11	10	11							
			$n_{2 \text{ th}}$		11	11	11	10	11							
394.245	1250	0.26	M_2	171	355	447	693	939								
			c	5.7	2.9	2.3	1.5	1.1								
			$n_{2 \text{ Eck}}$	10	10	10	10	10								
			$n_{2 \text{ th}}$	10	10	10	10	10								
445.116	1250	0.26	M_2	189	393	495	767	1038								
			c	5.7	2.9	2.3	1.5	1.1								
			$n_{2 \text{ Eck}}$	9	9	9	9	8								
			$n_{2 \text{ th}}$	9	9	9	9	8								
490.403	1250	0.18	M_2	211	436	548	848									
			c	5.0	2.5	2.0	1.3									
			$n_{2 \text{ Eck}}$	8	8	8	8									
			$n_{2 \text{ th}}$	8	8	8	8									

$M \dots$ [Nm]
 $n \dots$ [r/min]
 $J \dots$ [kgcm²]

$P \dots$ [kW]
 $I \dots$ [A]
 $i \dots$ [-]
 $c \dots$ [-]

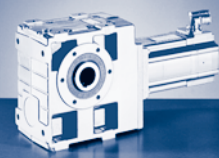

$M_{2GN} \leq 1250 \text{ Nm}$

GSS07-3S				06CC41	06FC41	06IC41	09DC41	09FC38	09HC41	09LC41	12DC20	12DC41	12HC15	12HC30	12HC35
				...S00	...S00	...S00	...S00	...S00	...S00	...S00	...S00	...S00	...S00	...S00	...S00
i	M_{2GN}	J_G	M_1	0.60	1.20	1.50	2.30	3.10	3.80	4.50	5.50	4.30	10.00	8.00	7.50
			n_1	4050	4050	4050	4050	3750	4050	4050	1950	4050	1500	3000	3525
			I_{M230}	2.6	2.9	3.2	4.6	5.0	6.8	8.4	5.2	8.8	7.6	10.5	
			I_{M400}	1.3	1.5	1.6	2.3	2.5	3.4	4.2	2.6	4.5	3.8		5.7
			P_N	0.25	0.51	0.64	1.00	1.20	1.60	1.90	1.10	1.80	1.60	2.50	2.80
			J_M	0.17	0.25	0.33	1.13	1.53	1.93	2.83	4.12	4.12	7.42	7.42	7.42
553.681	1250	0.18	M_2	235	485	610	943								
			c	4.8	2.4	1.9	1.3								
			$n_{2 \text{ Eck}}$	7	7	7	7								
			$n_{2 \text{ th}}$	7	7	7	7								
634.639	1250	0.11	M_2	272	559	703									
			c	4.2	2.1	1.7									
			$n_{2 \text{ Eck}}$	6	6	6									
			$n_{2 \text{ th}}$	6	6	6									
716.528	1250	0.11	M_2	303	622	782									
			c	3.7	1.9	1.5									
			$n_{2 \text{ Eck}}$	6	6	6									
			$n_{2 \text{ th}}$	6	6	6									
833.556	1250	0.11	M_2	357	728	914									
			c	3.0	1.5	1.2									
			$n_{2 \text{ Eck}}$	5	5	5									
			$n_{2 \text{ th}}$	5	5	5									
941.111	1250	0.11	M_2	396	807	1013									
			c	2.9	1.4	1.2									
			$n_{2 \text{ Eck}}$	4	4	4									
			$n_{2 \text{ th}}$	4	4	4									
1011.633	1250	0.08	M_2	428	872	1093									
			c	2.6	1.3	1.1									
			$n_{2 \text{ Eck}}$	4	4	4									
			$n_{2 \text{ th}}$	4	4	4									
1142.167	1250	0.08	M_2	475	966										
			c	2.4	1.2										
			$n_{2 \text{ Eck}}$	4	4										
			$n_{2 \text{ th}}$	4	4										
1227.755	1250	0.07	M_2	513	1042										
			c	2.2	1.1										
			$n_{2 \text{ Eck}}$	3	3										
			$n_{2 \text{ th}}$	3	3										
1386.175	1250	0.07	M_2	569	1154										
			c	2.0	1.0										
			$n_{2 \text{ Eck}}$	3	3										
			$n_{2 \text{ th}}$	3	3										

M ... [Nm]
n ... [r/min]
J ... [kgcm²]

P ... [kW]
I ... [A]
i [-]
c [-]

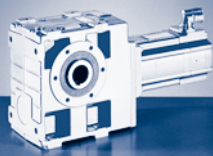

GSS [Nm]

GSS□□-□A (MCA)

$M_{2GN} \leq 180 \text{ Nm}$

GSS04-2A				10IC40	13IC34	13IC41
				...500	...F10	...500
i	M_{2GN}	J_G	M_1			
			n_1	3950	3410	4050
			I_{M400}	2.4	6.0	4.4
			P_N	0.80	2.20	1.70
			J_M	2.44	8.34	8.34
5.639	108	1.12	M_2	10		
			c	4.4		
			$n_{2 \text{ Eck}}$	701		
			$n_{2 \text{ th}}$	700		
5.639	149	1.12	M_2		31	20
			c		1.7	2.2
			$n_{2 \text{ Eck}}$		605	718
			$n_{2 \text{ th}}$		605	718
7.733	149	0.65	M_2	13		
			c	5.4		
			$n_{2 \text{ Eck}}$	511		
			$n_{2 \text{ th}}$	511		
7.733	158	0.65	M_2		43	27
			c		2.0	2.7
			$n_{2 \text{ Eck}}$		441	524
			$n_{2 \text{ th}}$		441	524
9.042	154	0.81	M_2		50	31
			c		2.1	3.1
			$n_{2 \text{ Eck}}$		377	448
			$n_{2 \text{ th}}$		377	448
9.897	161	0.43	M_2	17	55	35
			c	5.7	2.1	2.9
			$n_{2 \text{ Eck}}$	399	345	409
			$n_{2 \text{ th}}$	399	345	409
10.827	161	0.37	M_2	18	61	38
			c	5.7	2.1	2.9
			$n_{2 \text{ Eck}}$	365	315	374
			$n_{2 \text{ th}}$	365	315	374
12.400	170	0.49	M_2	21	69	43
			c	5.5	1.8	2.7
			$n_{2 \text{ Eck}}$	319	275	327
			$n_{2 \text{ th}}$	319	275	327
13.810	163	0.25	M_2	24	78	49
			c	5.8	1.9	2.9
			$n_{2 \text{ Eck}}$	286	247	293
			$n_{2 \text{ th}}$	286	247	293
15.869	180	0.33	M_2	27	88	55
			c	4.7	1.6	2.3
			$n_{2 \text{ Eck}}$	249	215	255
			$n_{2 \text{ th}}$	249	215	255
17.360	180	0.28	M_2	30	96	61
			c	4.4	1.5	2.2
			$n_{2 \text{ Eck}}$	228	196	233
			$n_{2 \text{ th}}$	228	196	233
20.417	153	0.67	M_2	32	103	65
			c	3.2	1.1	1.6
			$n_{2 \text{ Eck}}$	194	167	198
			$n_{2 \text{ th}}$	193	167	198
22.143	180	0.20	M_2	38	123	78
			c	3.8	1.2	1.9
			$n_{2 \text{ Eck}}$	178	154	183
			$n_{2 \text{ th}}$	178	154	183

$M \dots$ [Nm]
 $n \dots$ [r/min]
 $J \dots$ [kgcm²]

$P \dots$ [kW]
 $I \dots$ [A]
 i [-]
 c [-]

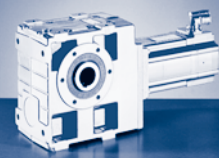

$M_{2GN} \leq 180 \text{ Nm}$

GSS04-2A				10IC40	13IC34	13IC41
				...500	...F10	...500
i	M_{2GN}	J_G	M_1			
			n_1	3950	3410	4050
			I_{M400}	2.4	6.0	4.4
			P_N	0.80	2.20	1.70
			J_M	2.44	8.34	8.34
24.800	171	0.42	M_2	40		81
			c	2.9		1.5
			$n_{2 \text{ Eck}}$	159		163
			$n_{2 \text{ th}}$	159		163
27.125	180	0.14	M_2	47	150	95
			c	3.3	1.1	1.6
			$n_{2 \text{ Eck}}$	146	126	149
			$n_{2 \text{ th}}$	146	126	149
31.738	180	0.29	M_2	51		104
			c	2.5		1.3
			$n_{2 \text{ Eck}}$	125		128
			$n_{2 \text{ th}}$	124		128
34.100	180	0.10	M_2	59		
			c	2.8		
			$n_{2 \text{ Eck}}$	116		
			$n_{2 \text{ th}}$	116		
39.200	180	0.25	M_2	62		126
			c	2.1		1.1
			$n_{2 \text{ Eck}}$	101		103
			$n_{2 \text{ th}}$	101		103
43.917	180	0.06	M_2	76		
			c	2.3		
			$n_{2 \text{ Eck}}$	90		
			$n_{2 \text{ th}}$	90		
50.000	180	0.17	M_2	79		
			c	1.8		
			$n_{2 \text{ Eck}}$	79		
			$n_{2 \text{ th}}$	79		
54.250	180	0.13	M_2	87		
			c	1.8		
			$n_{2 \text{ Eck}}$	73		
			$n_{2 \text{ th}}$	73		
61.250	180	0.13	M_2	96		
			c	1.6		
			$n_{2 \text{ Eck}}$	65		
			$n_{2 \text{ th}}$	64		
68.200	180	0.09	M_2	109		
			c	1.5		
			$n_{2 \text{ Eck}}$	58		
			$n_{2 \text{ th}}$	58		
77.000	180	0.09	M_2	120		
			c	1.4		
			$n_{2 \text{ Eck}}$	51		
			$n_{2 \text{ th}}$	51		
87.833	180	0.06	M_2	140		
			c	1.3		
			$n_{2 \text{ Eck}}$	45		
			$n_{2 \text{ th}}$	45		
99.167	180	0.06	M_2	154		
			c	1.2		
			$n_{2 \text{ Eck}}$	40		
			$n_{2 \text{ th}}$	40		

M ... [Nm]
n ... [r/min]
J ... [kgcm²]

P ... [kW]
I ... [A]
i [-]
c [-]

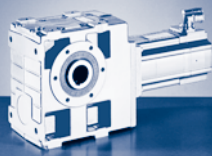

GSS [Nm]

GSS□□-□A (MCA)

$M_{2GN} \leq 360 \text{ Nm}$

GSS05-2A				10IC40	13IC34	13IC41	14LC16	14LC20	14LC35	14LC41
				...S00	...F10	...S00	...F10	...S00	...F10	...S00
i	M_{2GN}	J_G	M_1							
			n_1	3950	3410	4050	1635	2000	3455	4100
			I_{M400}	2.4	6.0	4.4	4.8	3.3	9.1	5.8
			P_N	0.80	2.20	1.70	2.10	1.40	3.90	2.30
			J_M	2.44	8.34	8.34	19.32	19.24	19.24	19.24
5.639	219	2.82	M_2		31	19				
			c		3.8	5.4				
			$n_{2 \text{ Eck}}$		605	718				
			$n_{2 \text{ th}}$		605	718				
5.639	223	2.82	M_2				60	33	54	26
			c				3.2	5.1	2.2	4.0
			$n_{2 \text{ Eck}}$				290	355	613	727
			$n_{2 \text{ th}}$				290	355	613	637
7.733	267	1.66	M_2		43	27	83	45	75	37
			c		3.4	4.9	2.9	4.7	2.0	3.6
			$n_{2 \text{ Eck}}$		441	524	211	259	447	530
			$n_{2 \text{ th}}$		441	524	211	259	447	464
9.042	251	2.01	M_2		48	30	94	52	84	41
			c		2.6	3.3	2.5	4.2	1.5	2.5
			$n_{2 \text{ Eck}}$		377	448	181	221	382	454
			$n_{2 \text{ th}}$		377	448	181	221	382	397
9.897	271	1.10	M_2		55	35	107	58	96	47
			c		3.2	4.6	2.5	4.3	1.8	3.4
			$n_{2 \text{ Eck}}$		345	409	165	202	349	414
			$n_{2 \text{ th}}$		345	409	165	202	349	363
10.827	272	0.94	M_2		61	38	117	64	105	52
			c		3.1	4.4	2.3	4.0	1.8	3.3
			$n_{2 \text{ Eck}}$		315	374	151	185	319	379
			$n_{2 \text{ th}}$		315	374	151	185	319	332
12.400	279	1.24	M_2		67	42	130	72	117	57
			c		2.7	3.8	2.0	3.4	1.6	2.8
			$n_{2 \text{ Eck}}$		275	327	132	161	279	331
			$n_{2 \text{ th}}$		275	327	132	161	279	290
13.810	275	0.64	M_2		78	49	151	83	135	66
			c		2.9	4.1	1.8	3.2	1.7	3.1
			$n_{2 \text{ Eck}}$		247	293	118	145	250	297
			$n_{2 \text{ th}}$		247	293	118	145	250	260
15.869	301	0.84	M_2		87	54	168	92	150	74
			c		2.5	3.8	1.7	2.9	1.5	2.8
			$n_{2 \text{ Eck}}$		215	255	103	126	218	258
			$n_{2 \text{ th}}$		215	255	103	126	218	226
17.360	311	0.72	M_2		95	60	184	101	165	81
			c		2.4	3.6	1.6	2.7	1.4	2.7
			$n_{2 \text{ Eck}}$		196	233	94	115	199	236
			$n_{2 \text{ th}}$		196	233	94	115	199	207
20.417	253	1.60	M_2		99	62	196	108		85
			c		1.4	2.1	1.2	2.0		1.5
			$n_{2 \text{ Eck}}$		167	198	80	98		201
			$n_{2 \text{ th}}$		167	198	80	98		176
22.143	337	0.50	M_2		122	77	235	130	211	104
			c		2.0	3.1	1.3	2.3	1.2	2.3
			$n_{2 \text{ Eck}}$		154	183	74	90	156	185
			$n_{2 \text{ th}}$		154	183	74	90	156	162
24.800	280	1.06	M_2		125	79	245	135		107
			c		1.6	2.2	1.1	1.8		1.6
			$n_{2 \text{ Eck}}$		138	163	66	81		165
			$n_{2 \text{ th}}$		138	163	66	81		145

$M \dots$ [Nm]
 $n \dots$ [r/min]
 $J \dots$ [kgcm²]

$P \dots$ [kW]
 $I \dots$ [A]
 i [-]
 c [-]

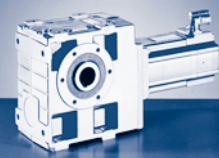

$M_{2GN} \leq 360 \text{ Nm}$

GSS05-2A				10IC40	13IC34	13IC41	14LC16	14LC20	14LC35	14LC41
				...S00	...F10	...S00	...F10	...S00	...F10	...S00
i	M_{2GN}	J_G	M_1	2.00	6.30	4.00	12.00	6.70	10.80	5.40
			n_1	3950	3410	4050	1635	2000	3455	4100
			I_{M400}	2.4	6.0	4.4	4.8	3.3	9.1	5.8
			P_N	0.80	2.20	1.70	2.10	1.40	3.90	2.30
			J_M	2.44	8.34	8.34	19.32	19.24	19.24	19.24
27.125	360	0.38	M_2	46	150	94	288	160	260	128
			c	5.3	1.8	2.7	1.2	2.0	2.0	
			$n_{2 \text{ Eck}}$	146	126	149	60	74	127	151
			$n_{2 \text{ th}}$	146	126	149	60	74	127	132
31.738	306	0.73	M_2	50	162	102		174		139
			c	4.1	1.3	2.0		1.5		1.5
			$n_{2 \text{ Eck}}$	125	107	128		63		129
			$n_{2 \text{ th}}$	124	107	128		63		113
35.306	360	0.23	M_2	60	196	124				
			c	4.5	1.5	2.2				
			$n_{2 \text{ Eck}}$	112	97	115				
			$n_{2 \text{ th}}$	112	97	115				
39.200	323	0.61	M_2	61	198	125		211		169
			c	3.5	1.2	1.8		1.3		1.3
			$n_{2 \text{ Eck}}$	101	87	103		51		105
			$n_{2 \text{ th}}$	101	87	103		51		92
43.917	360	0.17	M_2	76	245	154				
			c	3.9	1.3	1.9				
			$n_{2 \text{ Eck}}$	90	78	92				
			$n_{2 \text{ th}}$	90	78	92				
50.000	353	0.44	M_2	79		160		271		217
			c	3.0		1.5		1.2		1.1
			$n_{2 \text{ Eck}}$	79		81		40		82
			$n_{2 \text{ th}}$	79		81		40		72
54.250	360	0.34	M_2	87		178		299		241
			c	2.9		1.4		1.1		1.1
			$n_{2 \text{ Eck}}$	73		75		37		76
			$n_{2 \text{ th}}$	73		75		37		66
61.250	360	0.33	M_2	97		197		332		
			c	2.6		1.3		1.0		
			$n_{2 \text{ Eck}}$	65		66		33		
			$n_{2 \text{ th}}$	64		66		33		
70.611	360	0.21	M_2	114		232				
			c	2.4		1.2				
			$n_{2 \text{ Eck}}$	56		57				
			$n_{2 \text{ th}}$	56		57				
79.722	360	0.21	M_2	127		258				
			c	2.2		1.1				
			$n_{2 \text{ Eck}}$	50		51				
			$n_{2 \text{ th}}$	50		51				
87.833	360	0.15	M_2	143		289				
			c	2.1		1.1				
			$n_{2 \text{ Eck}}$	45		46				
			$n_{2 \text{ th}}$	45		46				
99.167	360	0.15	M_2	159						
			c	2.0						
			$n_{2 \text{ Eck}}$	40						
			$n_{2 \text{ th}}$	40						
113.667	360	0.10	M_2	186						
			c	1.8						
			$n_{2 \text{ Eck}}$	35						
			$n_{2 \text{ th}}$	35						

M ... [Nm]
n ... [r/min]
J ... [kgcm²]

P ... [kW]
I ... [A]
i [-]
c [-]

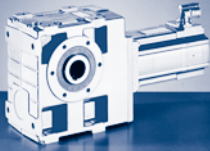

GSS [Nm]

GSS□□-□A (MCA)

$M_{2GN} \leq 360 \text{ Nm}$

GSS05-2A				10IC40	13IC34	13IC41	14LC16	14LC20	14LC35	14LC41
				...S00	...F10	...S00	...F10	...S00	...F10	...S00
i	M_{2GN}	J_G	M_1	2.00	6.30	4.00	12.00	6.70	10.80	5.40
			n_1	3950	3410	4050	1635	2000	3455	4100
			I_{M400}	2.4	6.0	4.4	4.8	3.3	9.1	5.8
			P_N	0.80	2.20	1.70	2.10	1.40	3.90	2.30
			J_M	2.44	8.34	8.34	19.32	19.24	19.24	19.24
128.333	360	0.09	M_2	206						
			c	1.7						
			n_{2Eck}	31						
			n_{2th}	31						
137.950	360	0.07	M_2	226						
			c	1.6						
			n_{2Eck}	29						
			n_{2th}	29						
155.750	360	0.07	M_2	251						
			c	1.4						
			n_{2Eck}	25						
			n_{2th}	25						

M ... [Nm]
 n ... [r/min]
 J ... [kgcm²]

P ... [kW]
 I ... [A]
 i [-]
 c [-]

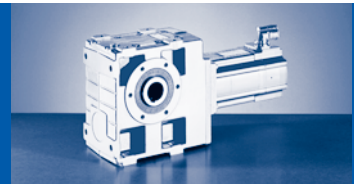

$M_{2GN} \leq 360 \text{ Nm}$

GSS05-3A				10IC40
				...500
i	M_{2GN}	J_G	M_1	2.00
			n_1	3950
			I_{M400}	2.4
			P_N	0.80
			J_M	2.44
125.476	339	0.15	M_2	218
			c	1.2
			n_{2Eck}	32
			n_{2th}	31
153.708	356	0.12	M_2	265
			c	1.0
			n_{2Eck}	26
			n_{2th}	26
222.133	360	0.21	M_2	353
			c	1.0
			n_{2Eck}	18
			n_{2th}	18

M ... [Nm]
n ... [r/min]
J ... [kgcm²]

P ... [kW]
I ... [A]
i [-]
c [-]

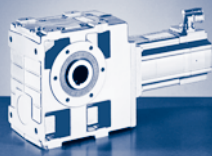

GSS [Nm]

GSS□□-□A (MCA)

$M_{2GN} \leq 720 \text{ Nm}$

GSS06-2A				10IC40	13IC34	13IC41	14LC16	14LC20	14LC35	14LC41	17NC17	17NC23	17NC35	17NC41
				...S00	...F10	...S00	...F10	...S00	...F10	...S00	...F10	...S00	...F10	...S00
i	M_{2GN}	J_G	M_1	2.00	6.30	4.00	12.00	6.70	10.80	5.40	21.50	10.80	19.00	9.50
			n_1	3950	3410	4050	1635	2000	3455	4100	1680	2300	3480	4110
			I_{M400}	2.4	6.0	4.4	4.8	3.3	9.1	5.8	8.5	5.5	15.8	10.2
			P_N	0.80	2.20	1.70	2.10	1.40	3.90	2.30	3.80	2.60	6.90	4.10
			J_M	2.44	8.34	8.34	19.32	19.24	19.24	19.24	36.04	36.04	36.04	36.04
5.833	356	6.97	M_2				61		56	27	113	56	100	49
			c			4.9		2.6	4.3	2.7	3.9	1.5	2.4	
			$n_{2 \text{ Eck}}$			280		592	703	288	394	597	705	
			$n_{2 \text{ th}}$			280		592	615	288	394	533	533	
8.000	489	4.22	M_2				85		77	38	155	77	137	68
			c			4.4		2.8	4.9	2.4	3.8	1.6	2.8	
			$n_{2 \text{ Eck}}$			204		432	513	210	288	435	514	
			$n_{2 \text{ th}}$			204		432	449	210	288	389	389	
9.042	417	5.54	M_2				95		86	42	173	86	153	76
			c			3.8		2.6	4.7	2.1	3.2	1.5	2.7	
			$n_{2 \text{ Eck}}$			181		382	454	186	254	385	455	
			$n_{2 \text{ th}}$			181		382	397	186	254	344	344	
10.238	397	2.81	M_2		57									
			c		4.8									
			$n_{2 \text{ Eck}}$		333									
			$n_{2 \text{ th}}$		333									
10.238	522	2.81	M_2				109		99	48	199	99	177	87
			c				4.5		2.8	5.0	2.5	3.5	1.6	2.9
			$n_{2 \text{ Eck}}$				160		338	401	164	225	340	401
			$n_{2 \text{ th}}$				160		337	351	164	225	304	304
11.200	440	2.39	M_2		62									
			c		4.7									
			$n_{2 \text{ Eck}}$		305									
			$n_{2 \text{ th}}$		304									
11.200	524	2.39	M_2				119		109	53	218	108	193	95
			c				4.2		2.8	5.0	2.4	3.4	1.6	2.8
			$n_{2 \text{ Eck}}$				146		309	366	150	205	311	367
			$n_{2 \text{ th}}$				146		308	321	150	205	278	278
12.400	523	3.46	M_2				130	71	119	58	237	118	211	104
			c				3.4	5.5	2.3	4.3	1.9	2.9	1.3	2.4
			$n_{2 \text{ Eck}}$				132	161	279	331	136	186	281	332
			$n_{2 \text{ th}}$				132	161	279	290	135	185	251	251
14.286	513	1.63	M_2		80									
			c		4.4									
			$n_{2 \text{ Eck}}$		239									
			$n_{2 \text{ th}}$		239									
14.286	528	1.63	M_2				154	83	139	68	281	138	248	122
			c				3.3	6.0	2.6	4.7	1.9	3.5	1.5	2.7
			$n_{2 \text{ Eck}}$				115	140	242	287	118	161	244	288
			$n_{2 \text{ th}}$				114	140	242	251	118	161	218	218
15.869	597	2.35	M_2		87	54								
			c		3.7	5.4								
			$n_{2 \text{ Eck}}$		215	255								
			$n_{2 \text{ th}}$		215	255								
15.869	605	2.35	M_2				166	91	152	75	303	151	270	134
			c				3.2	5.2	2.2	4.0	1.8	2.7	1.2	2.3
			$n_{2 \text{ Eck}}$				103	126	218	258	106	145	219	259
			$n_{2 \text{ th}}$				103	126	218	226	106	145	196	196
17.360	624	2.01	M_2		95	60	182	100	166	82	331	165	296	146
			c		3.6	5.2	3.1	5.0	2.1	3.9	1.8	2.7	1.2	2.2
			$n_{2 \text{ Eck}}$		196	233	94	115	199	236	97	133	201	237
			$n_{2 \text{ th}}$		196	233	94	115	199	207	97	132	179	179

$M \dots$ [Nm]
 $n \dots$ [r/min]
 $J \dots$ [kgcm²]

$P \dots$ [kW]
 $I \dots$ [A]
 $i \dots$ [-]
 $c \dots$ [-]

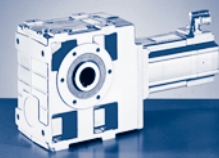

$M_{2GN} \leq 720 \text{ Nm}$

GSS06-2A				10IC40	13IC34	13IC41	14LC16	14LC20	14LC35	14LC41	17NC17	17NC23	17NC35	17NC41
				...S00	...F10	...S00	...F10	...S00	...F10	...S00	...F10	...S00	...F10	...S00
i	M_{2GN}	J_G	M_1	2.00	6.30	4.00	12.00	6.70	10.80	5.40	21.50	10.80	19.00	9.50
			n_1	3950	3410	4050	1635	2000	3455	4100	1680	2300	3480	4110
			I_{M400}	2.4	6.0	4.4	4.8	3.3	9.1	5.8	8.5	5.5	15.8	10.2
			P_N	0.80	2.20	1.70	2.10	1.40	3.90	2.30	3.80	2.60	6.90	4.10
			J_M	2.44	8.34	8.34	19.32	19.24	19.24	19.24	36.04	36.04	36.04	36.04
20.417	488	4.17	M_2				201	111	182	89	364	182		160
			c				2.1	3.4	1.4	2.6	1.2	1.8		1.5
			$n_{2 \text{ Eck}}$				80	98	169	201	82	113		201
			$n_{2 \text{ th}}$				80	98	169	176	82	113		152
22.143	673	1.39	M_2		122	76	232	127	212	104	422	211	377	187
			c		3.4	4.9	2.7	4.6	2.0	3.6	1.5	2.5	1.1	2.1
			$n_{2 \text{ Eck}}$		154	183	74	90	156	185	76	104	157	186
			$n_{2 \text{ th}}$		154	183	74	90	156	162	76	104	141	141
24.800	561	3.06	M_2				246	136	225	111	445	223		197
			c				2.0	3.3	1.4	2.5	1.1	1.7		1.4
			$n_{2 \text{ Eck}}$				66	81	139	165	68	93		166
			$n_{2 \text{ th}}$				66	81	139	145	68	93		125
27.125	718	1.04	M_2		149	93	285	156	260	128	516	258	462	229
			c		3.2	4.6	2.3	4.0	1.9	3.4	1.3	2.3	1.1	1.9
			$n_{2 \text{ Eck}}$		126	149	60	74	127	151	62	85	128	152
			$n_{2 \text{ th}}$		126	149	60	74	127	132	62	85	115	115
31.738	609	2.10	M_2		166	104	314	173	287	142	568	285		253
			c		2.2	3.1	1.8	3.0	1.3	2.3	1.0	1.6		1.3
			$n_{2 \text{ Eck}}$		107	128	52	63	109	129	53	73		130
			$n_{2 \text{ th}}$		107	128	52	63	109	113	53	72		98
35.306	720	0.66	M_2		195	122	371	204	338	166				
			c		2.9	4.3	1.9	3.3	1.7	3.2				
			$n_{2 \text{ Eck}}$		97	115	46	57	98	116				
			$n_{2 \text{ th}}$		97	115	46	57	98	102				
39.200	637	1.64	M_2		203	127	385	213	351	174		349		309
			c		2.0	2.9	1.6	2.6	1.2	2.2		1.5		1.2
			$n_{2 \text{ Eck}}$		87	103	42	51	88	105		59		105
			$n_{2 \text{ th}}$		87	103	42	51	88	92		59		79
43.917	720	0.48	M_2		242	152	460	255	420	207				
			c		2.6	3.8	1.6	2.8	1.5	2.9				
			$n_{2 \text{ Eck}}$		78	92	37	46	79	93				
			$n_{2 \text{ th}}$		78	92	37	46	79	82				
50.000	693	1.16	M_2	79	258	162	488	271	447	221		444		393
			c	5.5	1.9	2.7	1.3	2.2	1.1	2.0		1.3		1.2
			$n_{2 \text{ Eck}}$	79	68	81	33	40	69	82		46		82
			$n_{2 \text{ th}}$	79	68	81	33	40	69	72		46		62
54.250	720	0.96	M_2		282	177	534	296	488	242		484		429
			c		1.9	2.7	1.3	2.2	1.1	2.0		1.2		1.1
			$n_{2 \text{ Eck}}$		63	75	30	37	64	76		42		76
			$n_{2 \text{ th}}$		63	75	30	37	64	66		42		57
61.250	720	0.89	M_2		316	199	596	331	547	270		542		480
			c		1.7	2.6	1.2	2.0	1.0	1.9		1.1		1.1
			$n_{2 \text{ Eck}}$		56	66	27	33	56	67		38		67
			$n_{2 \text{ th}}$		56	66	27	33	56	59		38		51
70.611	720	0.61	M_2	112	366	230	690	384		313				
			c	4.8	1.6	2.4	1.0	1.8		1.8				
			$n_{2 \text{ Eck}}$	56	48	57	23	28		58				
			$n_{2 \text{ th}}$	56	48	57	23	28		51				
79.722	720	0.57	M_2	126	410	258		429		351				
			c	4.4	1.5	2.2		1.7		1.6				
			$n_{2 \text{ Eck}}$	50	43	51		25		51				
			$n_{2 \text{ th}}$	50	43	51		25		45				

$M \dots$ [Nm]
 $n \dots$ [r/min]
 $J \dots$ [kgcm²]

$P \dots$ [kW]
 $I \dots$ [A]
 i [-]
 c [-]

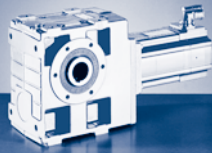

GSS [Nm]

GSS□□-□A (MCA)

$M_{2GN} \leq 720 \text{ Nm}$

GSS06-2A				10IC40	13IC34	13IC41	14LC16	14LC20	14LC35	14LC41	17NC17	17NC23	17NC35	17NC41
				...S00	...F10	...S00	...F10	...S00	...F10	...S00	...F10	...S00	...F10	...S00
i	M_{2GN}	J_G	M_1	2.00	6.30	4.00	12.00	6.70	10.80	5.40	21.50	10.80	19.00	9.50
			n_1	3950	3410	4050	1635	2000	3455	4100	1680	2300	3480	4110
			I_{M400}	2.4	6.0	4.4	4.8	3.3	9.1	5.8	8.5	5.5	15.8	10.2
			P_N	0.80	2.20	1.70	2.10	1.40	3.90	2.30	3.80	2.60	6.90	4.10
			J_M	2.44	8.34	8.34	19.32	19.24	19.24	19.24	36.04	36.04	36.04	36.04
87.833	720	0.44	M_2	140	455	286		475		389				
			c	4.2	1.4	2.1		1.5		1.6				
			$n_{2 \text{ Eck}}$	45	39	46		23		47				
			$n_{2 \text{ th}}$	45	39	46		23		41				
99.167	720	0.42	M_2	157	509	321		531		436				
			c	3.8	1.3	1.9		1.4		1.4				
			$n_{2 \text{ Eck}}$	40	34	41		20		41				
			$n_{2 \text{ th}}$	40	34	41		20		36				
113.667	720	0.28	M_2	181	587	370								
			c	3.6	1.2	1.8								
			$n_{2 \text{ Eck}}$	35	30	36								
			$n_{2 \text{ th}}$	35	30	36								
128.333	720	0.26	M_2	203	656	414								
			c	3.2	1.1	1.6								
			$n_{2 \text{ Eck}}$	31	27	32								
			$n_{2 \text{ th}}$	31	27	32								
137.950	720	0.20	M_2	219	709	447								
			c	3.2	1.0	1.6								
			$n_{2 \text{ Eck}}$	29	25	29								
			$n_{2 \text{ th}}$	29	25	29								
155.750	720	0.19	M_2	245		499								
			c	2.9		1.4								
			$n_{2 \text{ Eck}}$	25		26								
			$n_{2 \text{ th}}$	25		26								
174.375	720	0.13	M_2	276										
			c	2.5										
			$n_{2 \text{ Eck}}$	23										
			$n_{2 \text{ th}}$	23										
196.875	720	0.12	M_2	309										
			c	2.3										
			$n_{2 \text{ Eck}}$	20										
			$n_{2 \text{ th}}$	20										

M ... [Nm]
 n ... [r/min]
 J ... [kgcm²]

P ... [kW]
 I ... [A]
 i [-]
 c [-]

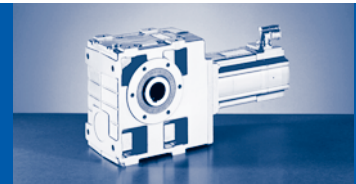

$M_{2GN} \leq 720 \text{ Nm}$

GSS06-3A				10IC40	13IC34
i	M_{2GN}	J_G	M_1	...500	...F10
			n_1	3950	3410
			I_{M400}	2.4	6.0
			P_N	0.80	2.20
			J_M	2.44	8.34
126.531	720	0.31	M_2	196	623
			c	1.9	1.1
			$n_{2 \text{ Eck}}$	31	27
			$n_{2 \text{ th}}$	31	27
142.857	720	0.30	M_2	218	695
			c	1.9	1.0
			$n_{2 \text{ Eck}}$	28	24
			$n_{2 \text{ th}}$	28	24
155.000	720	0.27	M_2	238	
			c	1.7	
			$n_{2 \text{ Eck}}$	26	
			$n_{2 \text{ th}}$	25	
175.000	720	0.26	M_2	265	
			c	1.7	
			$n_{2 \text{ Eck}}$	23	
			$n_{2 \text{ th}}$	23	
194.857	720	0.14	M_2	297	
			c	1.4	
			$n_{2 \text{ Eck}}$	20	
			$n_{2 \text{ th}}$	20	
220.000	720	0.14	M_2	331	
			c	1.4	
			$n_{2 \text{ Eck}}$	18	
			$n_{2 \text{ th}}$	18	
238.700	720	0.13	M_2	361	
			c	1.3	
			$n_{2 \text{ Eck}}$	17	
			$n_{2 \text{ th}}$	17	
269.500	720	0.12	M_2	401	
			c	1.3	
			$n_{2 \text{ Eck}}$	15	
			$n_{2 \text{ th}}$	15	

$M \dots$ [Nm]
 $n \dots$ [r/min]
 $J \dots$ [kgcm²]

$P \dots$ [kW]
 $I \dots$ [A]
 i [-]
 c [-]

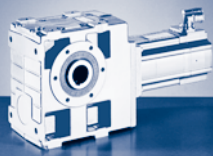

GSS [Nm]

GSS□□-□A (MCA)

$M_{2GN} \leq 1250 \text{ Nm}$

GSS07-2A				10IC40	13IC34	13IC41	14LC16	14LC20	14LC35	14LC41	17NC17	17NC23	
				...500	...F10	...500	...F10	...500	...F10	...500	...F10	...500	
i	M_{2GN}	J_G	M_1	2.00	6.30	4.00	12.00	6.70	10.80	5.40	21.50	10.80	
			n_1	3950	3410	4050	1635	2000	3455	4100	1680	2300	
			I_{M400}	2.4	6.0	4.4	4.8	3.3	9.1	5.8	8.5	5.5	
			P_N	0.80	2.20	1.70	2.10	1.40	3.90	2.30	3.80	2.60	
			J_M	2.44	8.34	8.34	19.32	19.24	19.24	19.24	36.04	36.04	
5.862	539	21.36	M_2								113		
			c								4.1		
			$n_{2 \text{ Eck}}$									287	
			$n_{2 \text{ th}}$									287	
8.125	685	12.75	M_2								157	77	
			c								3.7	5.6	
			$n_{2 \text{ Eck}}$									207	283
			$n_{2 \text{ th}}$									207	283
9.086	628	17.44	M_2								173	85	
			c								3.1	5.0	
			$n_{2 \text{ Eck}}$									185	253
			$n_{2 \text{ th}}$									185	253
10.000	746	9.14	M_2						96				
			c						4.2				
			$n_{2 \text{ Eck}}$						346				
			$n_{2 \text{ th}}$						346				
10.000	797	9.14	M_2								194	95	
			c								3.5	5.3	
			$n_{2 \text{ Eck}}$									168	230
			$n_{2 \text{ th}}$									168	230
11.200	775	7.50	M_2						108				
			c						4.1				
			$n_{2 \text{ Eck}}$						309				
			$n_{2 \text{ th}}$						308				
11.200	866	7.50	M_2								218	107	
			c								3.4	5.1	
			$n_{2 \text{ Eck}}$									150	205
			$n_{2 \text{ th}}$									150	205
12.594	799	10.71	M_2								240	119	
			c								2.9	4.3	
			$n_{2 \text{ Eck}}$									133	183
			$n_{2 \text{ th}}$									133	183
14.286	832	4.84	M_2				152		139				
			c				5.2		3.8				
			$n_{2 \text{ Eck}}$				115		242				
			$n_{2 \text{ th}}$				114		242				
14.286	973	4.84	M_2								279	137	
			c								3.2	4.8	
			$n_{2 \text{ Eck}}$									118	161
			$n_{2 \text{ th}}$									118	161
14.286	1036	4.84	M_2										
			c										
			$n_{2 \text{ Eck}}$										
			$n_{2 \text{ th}}$										
15.500	931	7.79	M_2				161		148		295	146	
			c				4.9		3.3		2.7	4.1	
			$n_{2 \text{ Eck}}$				106		223		108	148	
			$n_{2 \text{ th}}$				105		223		108	148	
17.360	1012	6.42	M_2				180		166	80	331	164	
			c				4.7		3.1	5.8	2.6	4.0	
			$n_{2 \text{ Eck}}$				94		199	236	97	133	
			$n_{2 \text{ th}}$				94		199	207	97	132	

$M \dots$ [Nm]
 $n \dots$ [r/min]
 $J \dots$ [kgcm²]

$P \dots$ [kW]
 $I \dots$ [A]
 i [-]
 c [-]

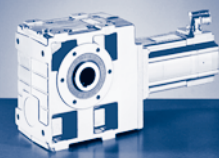

$M_{2GN} \leq 1250 \text{ Nm}$

17NC35	17NC41	19SC17	19SC23	19SC35	19SC42	21XC17	21XC25	21XC42	GSS07-2A			
...F10	...S00	...F10	...S00	...F10	...S00	...F10	...S00	...S00				
19.00	9.50	36.30	16.30	36.00	12.00	61.40	24.60	17.00	M_1	J_G	M_{2GN}	i
3480	4110	1700	2340	3510	4150	1710	2490	4160	n_1			
15.8	10.2	13.9	8.2	28.7	14.0	22.5	13.5	19.8	I_{M400}			
6.90	4.10	6.40	4.00	13.20	5.20	11.00	6.40	7.40	P_N			
36.04	36.04	72.12	72.12	72.04	72.12	180.04	180.04	180.04	J_M			
100	49	194	85	193	63	332	131	90	M_2			
2.8	5.1	2.4	4.1	1.5	4.0	1.4	2.7	2.8	c	21.36	539	5.862
594	701	290	399	599	708	292	425	710	$n_{2 \text{ Eck}}$			
531	531	290	399	418	418	292	343	343	$n_{2 \text{ th}}$			
140	68	270	119	269	87	461	182	125	M_2			
2.5	4.6	2.2	3.7	1.3	3.7	1.3	2.5	2.6	c	12.75	685	8.125
428	506	209	288	432	511	211	307	512	$n_{2 \text{ Eck}}$			
383	383	209	288	301	301	210	248	248	$n_{2 \text{ th}}$			
154	75	296	131	295	96	504	199	137	M_2			
2.4	4.5	1.8	3.3	1.3	3.6	1.1	2.2	2.5	c	17.44	628	9.086
383	452	187	258	386	457	188	274	458	$n_{2 \text{ Eck}}$			
342	342	187	258	269	269	188	222	222	$n_{2 \text{ th}}$			
									M_2			
									c	9.14	746	10.000
									$n_{2 \text{ Eck}}$			
									$n_{2 \text{ th}}$			
173	85	333	147	332	108	568	225	155	M_2			
2.4	4.4	2.1	3.5	1.3	3.5	1.2	2.3	2.5	c	9.14	797	10.000
348	411	170	234	351	415	171	249	416	$n_{2 \text{ Eck}}$			
311	311	170	234	245	245	171	201	201	$n_{2 \text{ th}}$			
									M_2			
									c	7.50	775	11.200
									$n_{2 \text{ Eck}}$			
									$n_{2 \text{ th}}$			
194	95	373	165	372	121	637	252	174	M_2			
2.3	4.2	2.0	3.4	1.2	3.4	1.2	2.3	2.4	c	7.50	866	11.200
311	367	152	209	313	371	153	222	371	$n_{2 \text{ Eck}}$			
278	278	152	209	219	219	153	180	180	$n_{2 \text{ th}}$			
214	105	410	182	410	134		278	191	M_2			
2.1	3.9	1.7	2.9	1.1	3.1		1.9	2.2	c	10.71	799	12.594
276	326	135	186	279	330		198	330	$n_{2 \text{ Eck}}$			
247	247	135	186	194	194		160	160	$n_{2 \text{ th}}$			
									M_2			
									c	4.84	832	14.286
									$n_{2 \text{ Eck}}$			
									$n_{2 \text{ th}}$			
248	122								M_2			
2.2	4.0								c	4.84	973	14.286
244	288								$n_{2 \text{ Eck}}$			
218	218								$n_{2 \text{ th}}$			
		477	211	476	155				M_2			
		1.9	3.2	1.1	3.1				c	4.84	1036	14.286
		119	164	246	291				$n_{2 \text{ Eck}}$			
		119	164	171	171				$n_{2 \text{ th}}$			
264	130	505	224		165		342	236	M_2			
1.9	3.5	1.6	2.7		2.8		1.8	2.0	c	7.79	931	15.500
225	265	110	151		268		161	268	$n_{2 \text{ Eck}}$			
201	201	110	151		158		130	130	$n_{2 \text{ th}}$			
296	145	565	251		185		383	265	M_2			
1.8	3.3	1.6	2.6		2.6		1.7	1.9	c	6.42	1012	17.360
201	237	98	135		239		143	240	$n_{2 \text{ Eck}}$			
179	179	98	135		141		116	116	$n_{2 \text{ th}}$			

M ... [Nm]
n ... [r/min]
J ... [kgcm²]

P ... [kW]
I ... [A]
i [-]
c [-]

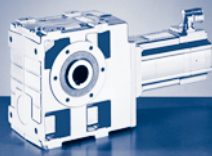

GSS [Nm]

GSS□□-□A (MCA)

$M_{2GN} \leq 1250 \text{ Nm}$

GSS07-2A				10IC40	13IC34	13IC41	14LC16	14LC20	14LC35	14LC41	17NC17	17NC23	
				...500	...F10	...500	...F10	...500	...F10	...500	...F10	...500	
i	M_{2GN}	J_G	M_1	2.00	6.30	4.00	12.00	6.70	10.80	5.40	21.50	10.80	
			n_1	3950	3410	4050	1635	2000	3455	4100	1680	2300	
			I_{M400}	2.4	6.0	4.4	4.8	3.3	9.1	5.8	8.5	5.5	
			P_N	0.80	2.20	1.70	2.10	1.40	3.90	2.30	3.80	2.60	
			J_M	2.44	8.34	8.34	19.32	19.24	19.24	19.24	36.04	36.04	
20.517	764	13.58	M_2								370	183	
			c								1.8	2.9	
			$n_{2 \text{ Eck}}$									82	112
			$n_{2 \text{ th}}$									82	112
22.143	836	4.18	M_2		121								
			c		5.0								
			$n_{2 \text{ Eck}}$		154								
			$n_{2 \text{ th}}$		154								
22.143	1211	4.18	M_2				230		212	103	421	210	
			c				4.4		2.9	5.4	2.5	3.7	
			$n_{2 \text{ Eck}}$				74		156	185	76	104	
			$n_{2 \text{ th}}$				74		156	162	76	104	
25.188	913	9.59	M_2								458	228	
			c								1.7	2.6	
			$n_{2 \text{ Eck}}$								67	91	
			$n_{2 \text{ th}}$								67	91	
27.125	1250	3.13	M_2				282		260	126	516	257	
			c				4.2		2.8	5.1	2.4	3.5	
			$n_{2 \text{ Eck}}$				60		127	151	62	85	
			$n_{2 \text{ th}}$				60		127	132	62	85	
31.000	1065	7.05	M_2				309	169	282	138	562	280	
			c				2.9	4.7	2.0	3.7	1.6	2.5	
			$n_{2 \text{ Eck}}$				53	65	112	132	54	74	
			$n_{2 \text{ th}}$				53	65	111	116	54	74	
35.306	1052	1.96	M_2		193								
			c		4.5								
			$n_{2 \text{ Eck}}$		97								
			$n_{2 \text{ th}}$		97								
35.306	1250	1.96	M_2				369	201	338	165	673	334	
			c				3.3	5.9	2.6	4.8	1.8	3.3	
			$n_{2 \text{ Eck}}$				46	57	98	116	48	65	
			$n_{2 \text{ th}}$				46	57	98	102	48	65	
39.200	1175	5.37	M_2				388	213	355	174	704	352	
			c				2.7	4.3	1.8	3.3	1.5	2.3	
			$n_{2 \text{ Eck}}$				42	51	88	105	43	59	
			$n_{2 \text{ th}}$				42	51	88	92	43	59	
43.271	1090	1.43	M_2		237								
			c		4.2								
			$n_{2 \text{ Eck}}$		79								
			$n_{2 \text{ th}}$		79								
43.271	1250	1.43	M_2				454	248	414	202	824	410	
			c				2.7	4.8	2.5	4.5	1.5	3.0	
			$n_{2 \text{ Eck}}$				38	46	80	95	39	53	
			$n_{2 \text{ th}}$				38	46	80	83	39	53	
50.000	1250	3.53	M_2		260	163	495	271	452	223	897	449	
			c		2.9	4.2	2.4	4.0	1.7	3.1	1.3	2.1	
			$n_{2 \text{ Eck}}$		68	81	33	40	69	82	34	46	
			$n_{2 \text{ th}}$		68	81	33	40	69	72	34	46	
54.250	1250	2.89	M_2				541	297	495	244	981	491	
			c				2.3	3.9	1.7	3.1	1.3	2.1	
			$n_{2 \text{ Eck}}$				30	37	64	76	31	42	
			$n_{2 \text{ th}}$				30	37	64	66	31	42	

$M \dots$ [Nm]
 $n \dots$ [r/min]
 $J \dots$ [kgcm²]

$P \dots$ [kW]
 $I \dots$ [A]
 i [-]
 c [-]

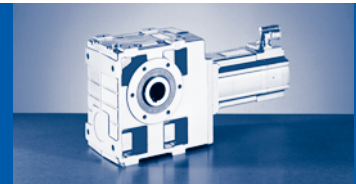

$M_{2GN} \leq 1250 \text{ Nm}$

17NC35	17NC41	19SC17	19SC23	19SC35	19SC42	21XC17	21XC25	21XC42	GSS07-2A			
...F10	...S00	...F10	...S00	...F10	...S00	...F10	...S00	...S00	M_1	J_G	M_{2GN}	i
19.00	9.50	36.30	16.30	36.00	12.00	61.40	24.60	17.00	n_1			
3480	4110	1700	2340	3510	4150	1710	2490	4160	l_{M400}			
15.8	10.2	13.9	8.2	28.7	14.0	22.5	13.5	19.8	P_N			
6.90	4.10	6.40	4.00	13.20	5.20	11.00	6.40	7.40	J_M			
36.04	36.04	72.12	72.12	72.04	72.12	180.04	180.04	180.04	M_2			
327	161	629	280		205		425	292	c	13.58	764	20.517
1.4	2.6	1.1	1.9		2.1		1.3	1.5	$n_{2\text{ Eck}}$			
170	200	83	114		202		121	203	$n_{2\text{ th}}$			
152	152	83	114		119		98	98				
									M_2	4.18	836	22.143
									c			
									$n_{2\text{ Eck}}$			
									$n_{2\text{ th}}$			
378	186	720	321		237				M_2	4.18	1211	22.143
1.7	3.1	1.5	2.5		2.4				c			
157	186	77	106		187				$n_{2\text{ Eck}}$			
141	141	77	106		111				$n_{2\text{ th}}$			
406	201	779	347		255		527	363	M_2	9.59	913	25.188
1.2	2.3	1.0	1.7		1.9		1.1	1.3	c			
138	163	68	93		165		99	165	$n_{2\text{ Eck}}$			
124	124	67	93		97		80	80	$n_{2\text{ th}}$			
463	228	880	393		290				M_2	3.13	1250	27.125
1.6	2.9	1.4	2.3		2.3				c			
128	152	63	86		153				$n_{2\text{ Eck}}$			
115	115	63	86		90				$n_{2\text{ th}}$			
501	248		427		314		649	448	M_2	7.05	1065	31.000
1.1	2.1		1.6		1.7		1.1	1.2	c			
112	133		76		134		80	134	$n_{2\text{ Eck}}$			
100	100		75		79		65	65	$n_{2\text{ th}}$			
									M_2	1.96	1052	35.306
									c			
									$n_{2\text{ Eck}}$			
									$n_{2\text{ th}}$			
602	297								M_2	1.96	1250	35.306
1.5	2.7								c			
99	116								$n_{2\text{ Eck}}$			
88	88								$n_{2\text{ th}}$			
630	312		536		396		814	563	M_2	5.37	1175	39.200
1.0	1.9		1.5		1.5		1.0	1.1	c			
89	105		60		106		64	106	$n_{2\text{ Eck}}$			
79	79		60		62		51	51	$n_{2\text{ th}}$			
									M_2	1.43	1090	43.271
									c			
									$n_{2\text{ Eck}}$			
									$n_{2\text{ th}}$			
737	364								M_2	1.43	1250	43.271
1.4	2.6								c			
80	95								$n_{2\text{ Eck}}$			
72	72								$n_{2\text{ th}}$			
	398		683		505				M_2	3.53	1250	50.000
	1.8		1.4		1.4				c			
	82		47		83				$n_{2\text{ Eck}}$			
	62		47		49				$n_{2\text{ th}}$			
	435		747		552				M_2	2.89	1250	54.250
	1.8		1.4		1.4				c			
	76		43		77				$n_{2\text{ Eck}}$			
	57		43		45				$n_{2\text{ th}}$			

M ... [Nm]
n ... [r/min]
J ... [kgcm²]

P ... [kW]
I ... [A]
i [-]
c [-]

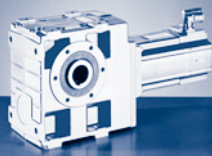

GSS [Nm]

GSS□□-□A (MCA)

$M_{2GN} \leq 1250 \text{ Nm}$

GSS07-2A				10IC40	13IC34	13IC41	14LC16	14LC20	14LC35	14LC41	17NC17	17NC23
				...500	...F10	...500	...F10	...500	...F10	...500	...F10	...500
i	M_{2GN}	J_G	M_1	2.00	6.30	4.00	12.00	6.70	10.80	5.40	21.50	10.80
			n_1	3950	3410	4050	1635	2000	3455	4100	1680	2300
			I_{M400}	2.4	6.0	4.4	4.8	3.3	9.1	5.8	8.5	5.5
			P_N	0.80	2.20	1.70	2.10	1.40	3.90	2.30	3.80	2.60
			J_M	2.44	8.34	8.34	19.32	19.24	19.24	19.24	36.04	36.04
61.250	1250	2.70	M_2				606	333	554	273	1097	549
			c				2.0	3.6	1.6	2.9	1.1	2.0
			$n_{2 \text{ Eck}}$				27	33	56	67	27	38
			$n_{2 \text{ th}}$				27	33	56	59	27	38
70.611	1250	1.81	M_2		370	232	703	388	643	317		638
			c		2.7	3.9	1.8	3.1	1.6	2.9		1.9
			$n_{2 \text{ Eck}}$		48	57	23	28	49	58		33
			$n_{2 \text{ th}}$		48	57	23	28	49	51		33
79.722	1250	1.70	M_2		414	260	787	435	719	354		714
			c		2.6	3.7	1.6	2.8	1.5	2.7		1.7
			$n_{2 \text{ Eck}}$		43	51	21	25	43	51		29
			$n_{2 \text{ th}}$		43	51	21	25	43	45		29
86.542	1250	1.34	M_2		454	284	858	475	788	388		781
			c		2.5	3.7	1.5	2.6	1.5	2.7		1.6
			$n_{2 \text{ Eck}}$		39	47	19	23	40	47		27
			$n_{2 \text{ th}}$		39	47	19	23	40	41		27
97.708	1250	1.26	M_2		508	318	961	533	881	434		874
			c		2.3	3.5	1.3	2.3	1.3	2.6		1.4
			$n_{2 \text{ Eck}}$		35	42	17	21	35	42		24
			$n_{2 \text{ th}}$		35	41	17	20	35	37		24
113.667	1250	0.83	M_2		596	373	1119	622	1032	509		
			c		2.1	3.2	1.1	2.0	1.2	2.4		
			$n_{2 \text{ Eck}}$		30	36	14	18	30	36		
			$n_{2 \text{ th}}$		30	36	14	18	30	32		
128.333	1250	0.79	M_2	202	667	418		697	1154	570		
			c	5.8	1.9	2.9		1.8	1.1	2.2		
			$n_{2 \text{ Eck}}$	31	27	32		16	27	32		
			$n_{2 \text{ th}}$	31	27	32		16	27	28		
137.950	1250	0.61	M_2	219	722	453		752	1247	616		
			c	5.4	1.7	2.7		1.7	1.0	2.0		
			$n_{2 \text{ Eck}}$	29	25	29		15	25	30		
			$n_{2 \text{ th}}$	29	25	29		15	25	26		
155.750	1250	0.58	M_2	247	808	508		841		691		
			c	4.8	1.5	2.4		1.5		1.8		
			$n_{2 \text{ Eck}}$	25	22	26		13		26		
			$n_{2 \text{ th}}$	25	22	26		13		23		
174.375	1250	0.39	M_2	278	908	571						
			c	4.3	1.4	2.2						
			$n_{2 \text{ Eck}}$	23	20	23						
			$n_{2 \text{ th}}$	23	20	23						
196.875	1250	0.37	M_2	313	1017	640						
			c	3.8	1.2	1.9						
			$n_{2 \text{ Eck}}$	20	17	21						
			$n_{2 \text{ th}}$	20	17	21						

$M \dots$ [Nm]
 $n \dots$ [r/min]
 $J \dots$ [kgcm²]

$P \dots$ [kW]
 $I \dots$ [A]
 i [-]
 c [-]

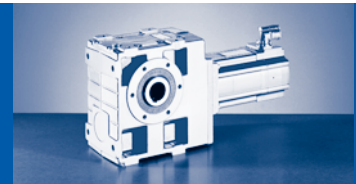

$M_{2GN} \leq 1250 \text{ Nm}$

17NC35	17NC41	19SC17	19SC23	19SC35	19SC42	21XC17	21XC25	21XC42	GSS07-2A			
...F10	...S00	...F10	...S00	...F10	...S00	...F10	...S00	...S00	M_1	J_G	M_{2GN}	i
19.00	9.50	36.30	16.30	36.00	12.00	61.40	24.60	17.00	n_1			
3480	4110	1700	2340	3510	4150	1710	2490	4160	I_{M400}			
15.8	10.2	13.9	8.2	28.7	14.0	22.5	13.5	19.8	P_N			
6.90	4.10	6.40	4.00	13.20	5.20	11.00	6.40	7.40	J_M			
36.04	36.04	72.12	72.12	72.04	72.12	180.04	180.04	180.04	M_2			
	487		835		617				c	2.70	1250	61.250
	1.7		1.3		1.3				$n_{2\text{ Eck}}$			
	67		38		68				$n_{2\text{ th}}$			
	51		38		40				M_2			
	565								c	1.81	1250	70.611
	1.6								$n_{2\text{ Eck}}$			
	58								$n_{2\text{ th}}$			
	44								M_2			
	632								c	1.70	1250	79.722
	1.6								$n_{2\text{ Eck}}$			
	52								$n_{2\text{ th}}$			
	39								M_2			
	692								c	1.34	1250	86.542
	1.6								$n_{2\text{ Eck}}$			
	48								$n_{2\text{ th}}$			
	36								M_2			
	774								c	1.26	1250	97.708
	1.5								$n_{2\text{ Eck}}$			
	42								$n_{2\text{ th}}$			
	32								M_2			
									c	0.83	1250	113.667
									$n_{2\text{ Eck}}$			
									$n_{2\text{ th}}$			
									M_2			
									c	0.79	1250	128.333
									$n_{2\text{ Eck}}$			
									$n_{2\text{ th}}$			
									M_2			
									c	0.61	1250	137.950
									$n_{2\text{ Eck}}$			
									$n_{2\text{ th}}$			
									M_2			
									c	0.58	1250	155.750
									$n_{2\text{ Eck}}$			
									$n_{2\text{ th}}$			
									M_2			
									c	0.39	1250	174.375
									$n_{2\text{ Eck}}$			
									$n_{2\text{ th}}$			
									M_2			
									c	0.37	1250	196.875
									$n_{2\text{ Eck}}$			
									$n_{2\text{ th}}$			

M ... [Nm]
n ... [r/min]
J ... [kgcm²]

P ... [kW]
I ... [A]
i [-]
c [-]

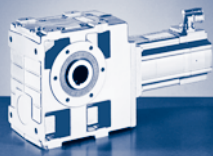

GSS [Nm]

GSS□□-□A (MCA)

$M_{2GN} \leq 1250 \text{ Nm}$

GSS07-3A				10IC40	13IC34	13IC41	14LC16	14LC20	14LC35	14LC41
				...500	...F10	...S00	...F10	...S00	...F10	...500
i	M_{2GN}	J_G	M_1							
			n_1	3950	3410	4050	1635	2000	3455	4100
			I_{M400}	2.4	6.0	4.4	4.8	3.3	9.1	5.8
			P_N	0.80	2.20	1.70	2.10	1.40	3.90	2.30
			J_M	2.44	8.34	8.34	19.32	19.24	19.24	19.24
126.531	1250	0.86	M_2	196	632	402	1186	660	1095	545
			c	3.8	2.0	1.9	1.1	1.9	1.1	1.4
			$n_{2 \text{ Eck}}$	31	27	32	13	16	27	32
			$n_{2 \text{ th}}$	31	27	32	13	16	27	28
142.857	1250	0.82	M_2	220	708	449		738	1225	610
			c	3.7	1.8	1.8		1.7	1.0	1.4
			$n_{2 \text{ Eck}}$	28	24	28		14	24	29
			$n_{2 \text{ th}}$	28	24	28		14	24	25
155.000	1250	0.74	M_2	239	772	489		805		664
			c	3.7	1.6	1.8		1.5		1.4
			$n_{2 \text{ Eck}}$	26	22	26		13		27
			$n_{2 \text{ th}}$	25	22	26		13		23
175.000	1250	0.72	M_2	268	866	548		898		743
			c	3.5	1.4	1.7		1.4		1.3
			$n_{2 \text{ Eck}}$	23	20	23		11		23
			$n_{2 \text{ th}}$	23	19	23		11		21
201.746	1250	0.37	M_2	310	999	632				
			c	3.2	1.3	1.6				
			$n_{2 \text{ Eck}}$	20	17	20				
			$n_{2 \text{ th}}$	20	17	20				
227.778	1250	0.36	M_2	347	1119	707				
			c	3.0	1.1	1.5				
			$n_{2 \text{ Eck}}$	17	15	18				
			$n_{2 \text{ th}}$	17	15	18				
247.139	1250	0.33	M_2	378	1218	770				
			c	2.8	1.0	1.4				
			$n_{2 \text{ Eck}}$	16	14	16				
			$n_{2 \text{ th}}$	16	14	16				
279.028	1250	0.32	M_2	422		859				
			c	2.7		1.3				
			$n_{2 \text{ Eck}}$	14		15				
			$n_{2 \text{ th}}$	14		15				
321.673	1250	0.28	M_2	493						
			c	1.9						
			$n_{2 \text{ Eck}}$	12						
			$n_{2 \text{ th}}$	12						
363.179	1250	0.28	M_2	547						
			c	1.9						
			$n_{2 \text{ Eck}}$	11						
			$n_{2 \text{ th}}$	11						
394.245	1250	0.26	M_2	601						
			c	1.7						
			$n_{2 \text{ Eck}}$	10						
			$n_{2 \text{ th}}$	10						
445.116	1250	0.26	M_2	665						
			c	1.7						
			$n_{2 \text{ Eck}}$	9						
			$n_{2 \text{ th}}$	9						
490.403	1250	0.18	M_2	735						
			c	1.5						
			$n_{2 \text{ Eck}}$	8						
			$n_{2 \text{ th}}$	8						

M ... [Nm]
n ... [r/min]
J ... [kgcm²]

P ... [kW]
I ... [A]
i [-]
c [-]

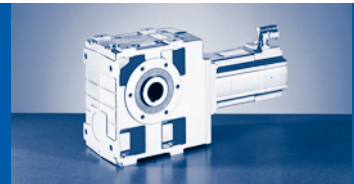

$M_{2GN} \leq 1250 \text{ Nm}$

GSS07-3A				10IC40	13IC34	13IC41	14LC16	14LC20	14LC35	14LC41
				...S00	...F10	...S00	...F10	...S00	...F10	...S00
i	M_{2GN}	J_G	M_1	2.00	6.30	4.00	12.00	6.70	10.80	5.40
			n_1	3950	3410	4050	1635	2000	3455	4100
			I_{M400}	2.4	6.0	4.4	4.8	3.3	9.1	5.8
			P_N	0.80	2.20	1.70	2.10	1.40	3.90	2.30
			J_M	2.44	8.34	8.34	19.32	19.24	19.24	19.24
553.681	1250	0.18	M_2	818						
			c	1.4						
			n_{2Eck}	7						
			n_{2th}	7						
634.639	1250	0.11	M_2	943						
			c	1.3						
			n_{2Eck}	6						
			n_{2th}	6						
716.528	1250	0.11	M_2	1048						
			c	1.1						
			n_{2Eck}	6						
			n_{2th}	6						

M ... [Nm]
n ... [r/min]
J ... [kgcm²]

P ... [kW]
I ... [A]
i [-]
c [-]

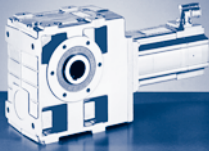

GSS [mm]

GSS□□-2S (MCS)

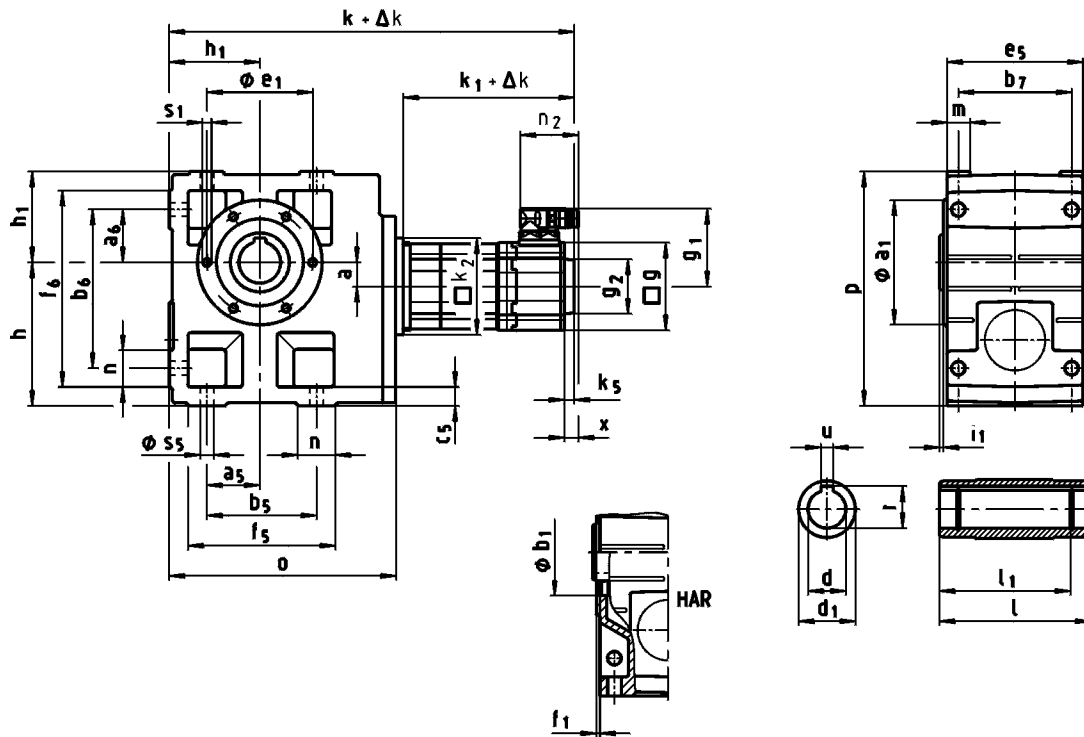

GSS□□-2S H□R ... RSO

		06C C41	06F C41	06I C41	09D C41	09F C38	09H C41	09L C41	12D C20	12D C41	12H C15	12H C30	12H C35	12L C20	12L C41	
GSS04...	k	325	355	385	378	398	418	458								
GSS05...	k	347	377	407	399	419	439	479	416			456			496	
GSS06...	k	387	417	447	439	459	479	519	456			496			536	
GSS07...	k				482	502	522	562	499			539			579	
...RSO B0 ¹⁾	Δk	0														
...RSO P□ ¹⁾	Δk	19				20										
	k_1	132	162	192	183	203	223	263	188			228			268	
	k_2	66			91							118	145 ²⁾			
	g	62				89						116				
...RSO	k_5	0				13						14				
	g_2	□ 62			Ø 67						Ø 72					
	g_1	76			90						105					
	n_2	64							78							
	x					21						18				

¹⁾ → 801 - SRS/SRM/ECN/EQN/EQI/C20

²⁾ GSS05: 12DC20 ... 12LC41

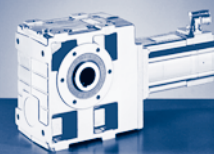

GSS□□-2S H□R ... RSO

		14D C15	14D C36	14H C15	14H C32	14L C15	14L C32	14P C14	14P C32	19F C14	19F C30	19J C14	19J C30	19P C14	19P C30
GSS06...	k	472		512		552		592							
GSS07...	k	515		555		595		635		554		594		654	
...RSO B0 ¹⁾	Δ k	0													
...RSO P□ ¹⁾	Δ k	28						34			44				
	k ₁	201		241		281		321		220		260		320	
	k ₂	145						195							
	g	143						192							
...RSO	k ₅	24						15							
	g ₂	Ø 78													
	g ₁	116				147		116	147	141	172	141	172	141	172
	n ₂	78				94		78	94	78	94	78	94	78	94
	x	16				38		16	38	16	36	16	36	16	36

¹⁾ →  801 - SRS/SRM/ECN/EQN/EQI/C20

GSS□□-2S H□R

	o	p	h	h ₁	a	a ₅	a ₆	b ₅	b ₆	b ₇	c ₅	e ₅	f ₅	f ₆	m	n	s ₅
GSS04...	181	171	100	71	20	45	45	90	119	85	14	100	112	141	20	22	9
GSS05...	212	205	125	80	23	47.5	47.5	95	140	105	17	127	124	169	21	29	11
GSS06...	255	250	150	100	26	60	60	120	170	120	20	145	156	206	23	36	14
GSS07...	305	310	190	120	33	70	70	140	210	150	25	180	185	255	28	45	18

	d	l	d ₁	l ₁	u	t	a ₁	b ₁	e ₁	f ₁	i ₁	s ₁
	H7				JS9	+0,2		H7				6x60°
GSS04...	25	115	45	100	8	28.3	105	75	90	3	2.5	M6x12
	30					33.3						
GSS05...	35	140	50	124	10	38.3	118	80	100	4	4	M8x15
	40					43.3						
GSS06...	45	160	65	140	14	48.8	140	100	120	5	5	M10x16
	50					53.8						
GSS07...	55	200	75	175	16	59.3	165	115	140	5	5	M12x18

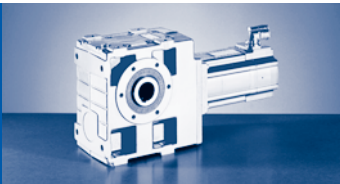

GSS [mm]

GSS□□-2S (MCS)

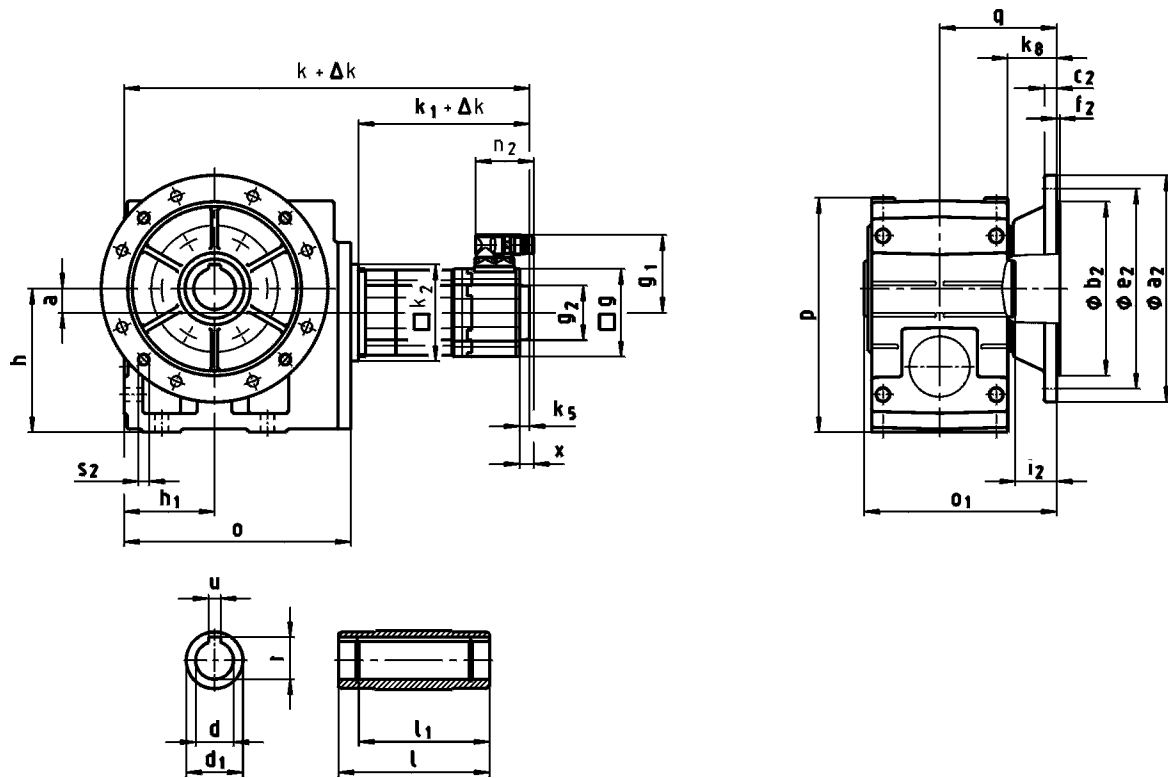

GSS□□-2S HAK ... RSO

		06C C41	06F C41	06I C41	09D C41	09F C38	09H C41	09L C41	12D C20	12D C41	12H C15	12H C30	12H C35	12L C20	12L C41	
GSS04...	k	325	355	385	378	398	418	458								
GSS05...	k	347	377	407	399	419	439	479	416			456			496	
GSS06...	k	387	417	447	439	459	479	519	456			496			536	
GSS07...	k				482	502	522	562	499			539			579	
...RSO B0 ¹⁾	Δk	0														
...RSO P□ ²⁾	Δk	19									20					
	k_1	132	162	192	183	203	223	263	188			228			268	
	k_2	66			91						118			145 ²⁾		
...RSO	g	62			89						116					
	k_5	0			13						14					
	g_2	□ 62			Ø 67						Ø 72					
	g_1	76			90						105					
	n_2	64			78											
	x	21									18					

¹⁾ → 801 - SRS/SRM/ECN/EQN/EQI/C20

²⁾ GSS05: 12DC20 ... 12LC41

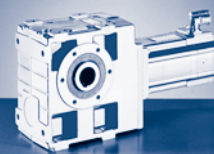

GSS□□-2S HAK ... RSO

		14D C15	14D C36	14H C15	14H C32	14L C15	14L C32	14P C14	14P C32	19F C14	19F C30	19J C14	19J C30	19P C14	19P C30				
GSS06...	k	472		512		552		592											
GSS07...	k	515		555		595		635		554		594		654					
...RSO B0 ¹⁾	Δ k	0																	
...RSO P□ ¹⁾	Δ k	28						34			44								
	k ₁	201		241		281		321		220		260		320					
	k ₂	145						195											
	g	143						192											
...RSO	k ₅	24						15											
	g ₂	Ø 78																	
	g ₁	116				147		116		147		141		172		141		172	
	n ₂	78				94		78		94		78		94		78		94	
	x	16				38		16		38		16		36		16		36	

¹⁾ →  801 - SRS/SRM/ECN/EQN/EQI/C20

GSS□□-2S HAK

	o	o ₁	p	h	h ₁	a	q	k ₈
GSS04...	181	149	171	100	71	20	91	41
GSS05...	212	174	205	125	80	23	103.5	40
GSS06...	255	203 ²⁾ 202 ³⁾	250	150	100	26	122.5 ²⁾ 121.5 ³⁾	50 ²⁾ 49 ³⁾
GSS07...	305	256	310	190	120	33	155.5	66

²⁾ a₂ = 200

³⁾ a₂ = 250

	d	l	d ₁	l ₁	u	t	a ₂	b ₂	c ₂	e ₂	f ₂	i ₂	s ₂
	H7				JS9	+0,2		j7					
GSS04...	25	115	45	100	8	28.3	160	110	10	130	3.5	33.5	4 x 9
	30					33.3							
GSS05...	35	140	50	124	10	38.3	200	130	12	165	3.5	33.5	4 x 11
	40					43.3							
GSS06...	45	160	65	140	12	48.8	250	180	15	215	4	41.5	4 x 14
	50					53.8							
GSS07...	55	200	75	175	14	59.3	300	230	17	265	4	55.5	4 x 14
						16							

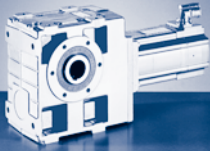

GSS [mm]

GSS□□-2S (MCS)

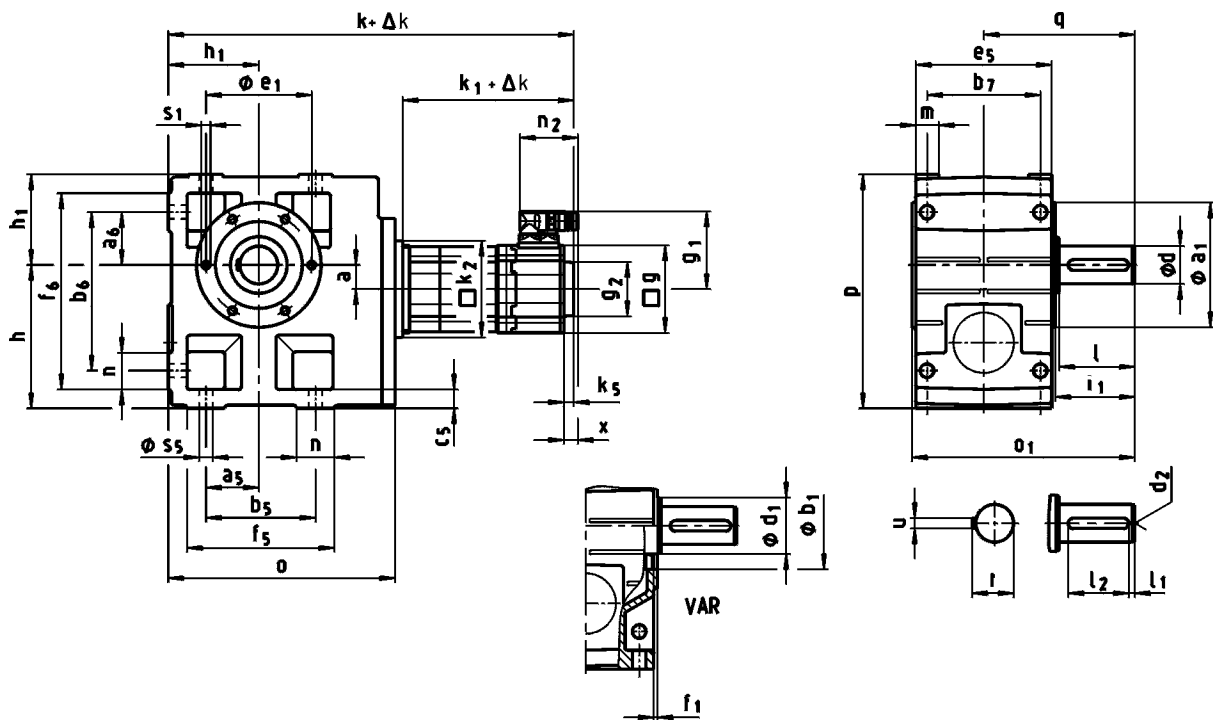

GSS□□-2S V□R ... RSO

		06C C41	06F C41	06I C41	09D C41	09F C38	09H C41	09L C41	12D C20	12D C41	12H C15	12H C30	12H C35	12L C20	12L C41	
GSS04...	k	325	355	385	378	398	418	458								
GSS05...	k	347	377	407	399	419	439	479	416		456			496		
GSS06...	k	387	417	447	439	459	479	519	456		496			536		
GSS07...	k				482	502	522	562	499		539			579		
...RSO B0 ¹⁾	Δk	0														
...RSO P□ ²⁾	Δk	19				20										
...RSO	k_1	132	162	192	183	203	223	263	188		228			268		
	k_2	66			91				118				145 ²⁾			
	g	62			89				116							
	k_5	0			13				14							
	g_2	□ 62			Ø 67				Ø 72							
	g_1	76			90				105							
	n_2	64			78											
x	21							18								

¹⁾ → 801 - SRS/SRM/ECN/EQN/EQI/C20

²⁾ GSS05: 12DC20 ... 12LC41

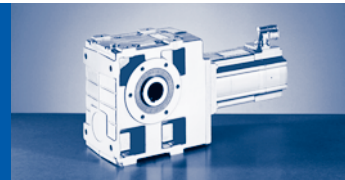

GSS□□-2S V□R ... RSO

		14D C15	14D C36	14H C15	14H C32	14L C15	14L C32	14P C14	14P C32	19F C14	19F C30	19J C14	19J C30	19P C14	19P C30				
GSS06...	k	472		512		552		592											
GSS07...	k	515		555		595		635		554		594		654					
...RSO B0 ¹⁾	Δ k	0																	
...RSO P□ ¹⁾	Δ k	28						34			44								
	k ₁	201		241		281		321		220		260		320					
	k ₂	145						195											
	g	143						192											
...RSO	k ₅	24						15											
	g ₂	Ø 78																	
	g ₁	116				147		116		147		141		172		141		172	
	n ₂	78				94		78		94		78		94		78		94	
	x	16				38		16		38		16		36		16		36	

¹⁾ →  801 - SRS/SRM/ECN/EQN/EQI/C20

GSS□□-2S V□R

	o	o ₁	p	h	h ₁	a	q	a ₅	a ₆	b ₅	b ₆	b ₇	c ₅	e ₅	f ₅	f ₆	m	n	s ₅
GSS04...	181	163	171	100	71	20	107.5	45	45	90	119	85	14	100	112	141	20	22	9
GSS05...	212	197	205	125	80	23	130	47.5	47.5	95	140	105	17	127	124	169	21	29	11
GSS06...	255	236	250	150	100	26	160	60	60	120	170	120	20	145	156	206	23	36	14
GSS07...	305	296	310	190	120	33	200	70	70	140	210	150	25	180	185	255	28	45	18

	d	l	d ₁	l ₁	l ₂	d ₂	u	t	a ₁	b ₁	e ₁	f ₁	i ₁	s ₁
										H7				6x60°
GSS04...	25	50	45	4	40	M10	8	28	105	75	90	3	52.5	M6x12
GSS05...	30	60	50	6	45			33	118	80	100	4	64	M8x15
GSS06...	40	80	65	7	63	M16	14	43	140	100	120		85	M10x16
GSS07...	50	100	75	8	80			53.5	165	115	140	5	105	M12x18

d ≤ 50 mm: k6; d > 50 mm: m6

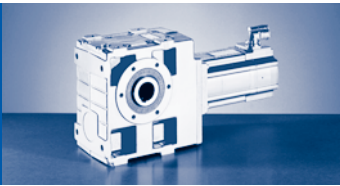

GSS [mm]

GSS□□-2S (MCS)

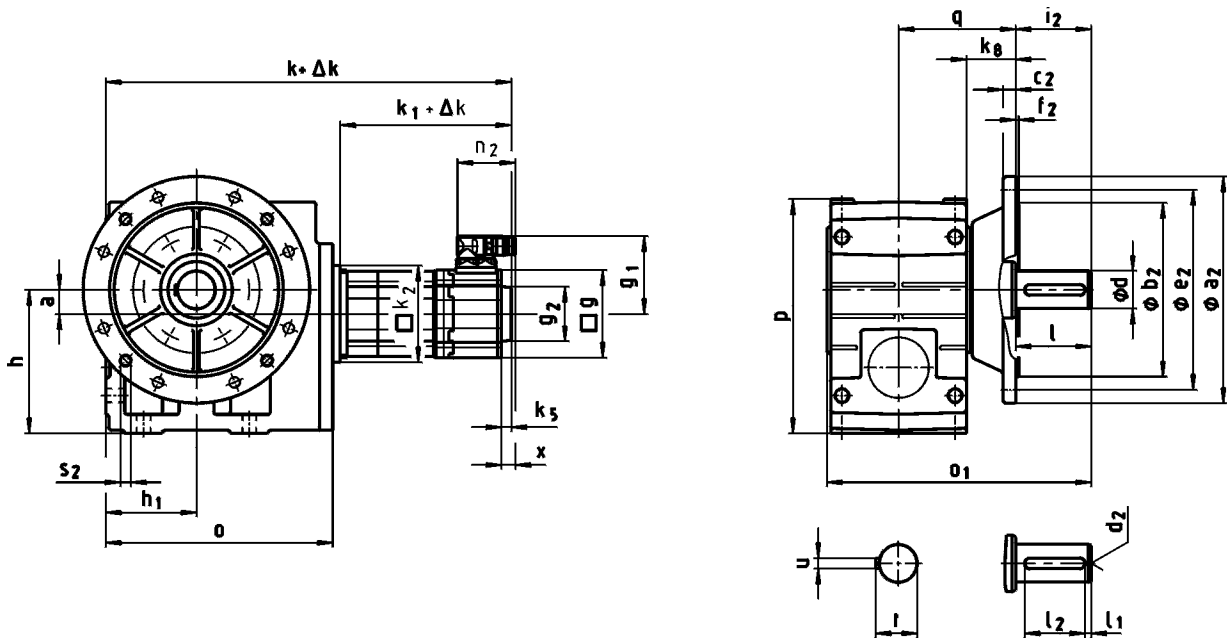

GSS□□-2S VAK ... RSO

		06C C41	06F C41	06I C41	09D C41	09F C38	09H C41	09L C41	12D C20	12D C41	12H C15	12H C30	12H C35	12L C20	12L C41
GSS04...	k	325	355	385	378	398	418	458							
GSS05...	k	347	377	407	399	419	439	479	416		456			496	
GSS06...	k	387	417	447	439	459	479	519	456		496			536	
GSS07...	k				482	502	522	562	499		539			579	
...RSO B0 ¹⁾	Δk	0													
...RSO P□ ¹⁾	Δk	19			20										
	k_1	132	162	192	183	203	223	263	188		228			268	
	k_2	66			91						118			145 ²⁾	
	g	62			89						116				
...RSO	k_5	0			13						14				
	g_2	□ 62			Ø 67						Ø 72				
	g_1	76			90						105				
	n_2	64							78						
	x				21						18				

¹⁾ → 801 - SRS/SRM/ECN/EQN/EQI/C20

²⁾ GSS05: 12DC20 ... 12LC41

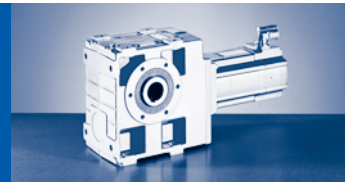

GSS□□-2S VAK ... RSO

		14D C15	14D C36	14H C15	14H C32	14L C15	14L C32	14P C14	14P C32	19F C14	19F C30	19J C14	19J C30	19P C14	19P C30				
GSS06...	k	472		512		552		592											
GSS07...	k	515		555		595		635		554		594		654					
...RSO B0 ¹⁾	Δ k	0																	
...RSO P□ ¹⁾	Δ k	28						34			44								
	k ₁	201		241		281		321		220		260		320					
	k ₂	145						195											
	g	143						192											
...RSO	k ₅	24						15											
	g ₂	Ø 78																	
	g ₁	116				147		116		147		141		172		141		172	
	n ₂	78				94		78		94		78		94		78		94	
	x	16				38		16		38		16		36		16		36	

¹⁾ →  801 - SRS/SRM/ECN/EQN/EQI/C20

GSS□□-2S VAK

	o	o ₁	p	h	h ₁	a	q	k ₈
GSS04...	181	196	171	100	71	20	91	41
GSS05...	212	230	205	125	80	23	103.5	40
GSS06...	255	277	250	150	100	26	121.5	49
GSS07...	305	351	310	190	120	33	155.5	66

	d	l	l ₁	l ₂	d ₂	u	t	a ₂	b ₂	c ₂	e ₂	f ₂	i ₂	s ₂
									j7					
GSS04...	25	50	4	40	M10	8	28	160	110	10	130	3.5	50	4 x 9
GSS05...	30	60	6	45			33	200	130	12	165		60	4 x 11
GSS06...	40	80	7	63	M16	14	43	250	180	15	215	4	80	4 x 14
GSS07...	50	100	8	80			53.5						300	

d ≤ 50 mm: k6; d > 50 mm: m6

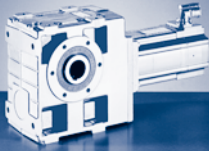

GSS [mm]

GSS□□-3S (MCS)

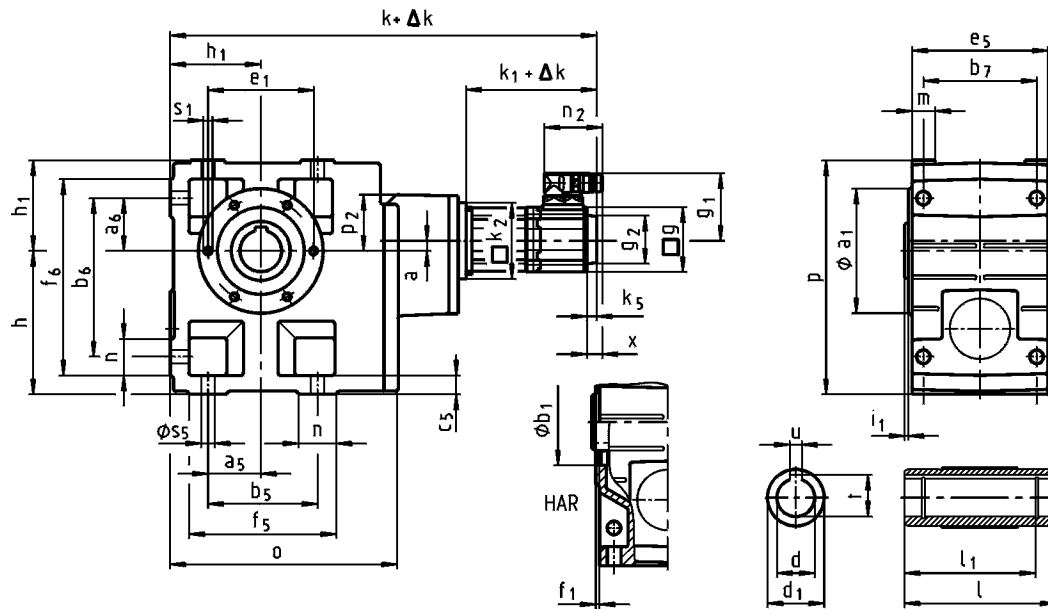

GSS□□-3S H□R ... RSO

		06C C41	06F C41	06I C41	09D C41	09F C38	09H C41	09L C41	12D C20	12D C41	12H C15	12H C30	12H C35	12L C20	12L C41	
GSS05...	k	423	453	483	476	496	516	556								
GSS06...	k	480	510	540	533	553	573	613								
GSS07...	k	534	564	594	587	607	627	667	604		644			684		
...RSO B0 ¹⁾	Δk	0														
...RSO P□ ²⁾	Δk	19				20										
	k_1	132	162	192	183	203	223	263	188		228		268			
	k_2	66			91						118		145 ²⁾			
	g	62				89						116				
...RSO	k_5	0				13						14				
	g_2	□ 62			Ø 67						Ø 72					
	g_1	76			90						105					
	n_2	64							78							
	x					21						18				

¹⁾ → 801 - SRS/SRM/ECN/EQN/EQI/C20

²⁾ GSS07: 12DC20 ... 12LC41

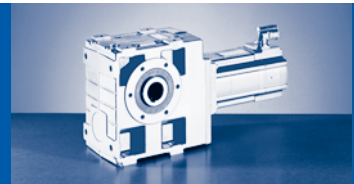

GSS□□-3S H□R

	o	p	p ₂	h	h ₁	a	a ₅	a ₆	b ₅	b ₆	b ₇	c ₅	e ₅	f ₅	f ₆	m	n	s ₅
GSS05...	209	205	65	125	80	13	47.5	47.5	95	140	105	17	127	124	169	21	29	11
GSS06...	252	250	63	150	100	10	60	60	120	170	120	20	145	156	206	23	36	14
GSS07...	299	310	73	190	120	12	70	70	140	210	150	25	180	185	255	28	45	18

	d	l	d ₁	l ₁	u	t	a ₁	b ₁	e ₁	f ₁	i ₁	s ₁
	H7				JS9	+0,2		H7				6x60°
GSS05...	30	140	50	124	8	33.3	118	80	100	4	4	M8x15
	35				10	38.3						
GSS06...	40	160	65	140	12	43.3	140	100	120		5	M10x16
	45				14	48.8						
GSS07...	50	200	75	175	14	53.8	165	115	140	5	M12x18	
	55				16	59.3						

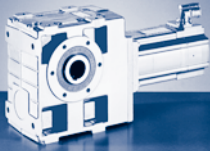

GSS [mm]

GSS□□-3S (MCS)

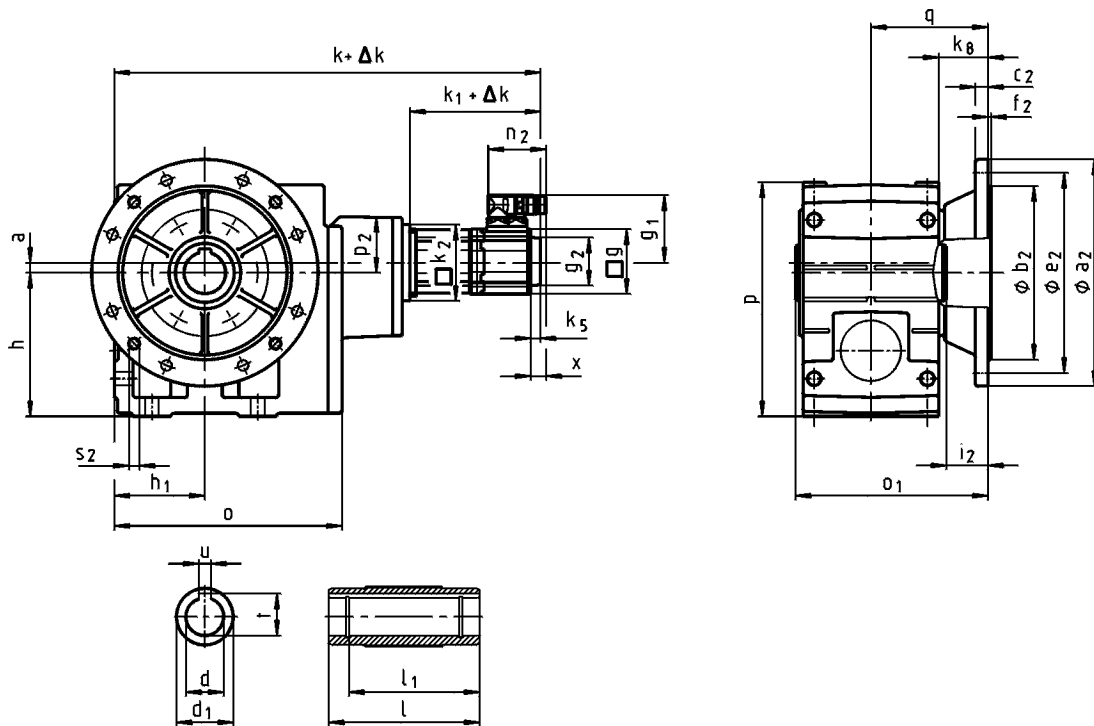

GSS□□-3S HAK ... RSO

		06C C41	06F C41	06I C41	09D C41	09F C38	09H C41	09L C41	12D C20	12D C41	12H C15	12H C30	12H C35	12L C20	12L C41	
GSS05...	k	423	453	483	476	496	516	556								
GSS06...	k	480	510	540	533	553	573	613								
GSS07...	k	534	564	594	587	607	627	667	604		644			684		
...RSO B0 ¹⁾	Δk	0														
...RSO P□ ¹⁾	Δk	19			20											
	k_1	132	162	192	183	203	223	263	188		228			268		
	k_2	66			91							118		145 ²⁾		
...RSO	g	62			89							116				
	k_5	0			13							14				
	g_2	□ 62			Ø 67							Ø 72				
	g_1	76			90							105				
	n_2	64							78							
	x				21							18				

¹⁾ → 801 - SRS/SRM/ECN/EQN/EQI/C20

²⁾ GSS07: 12DC20 ... 12LC41

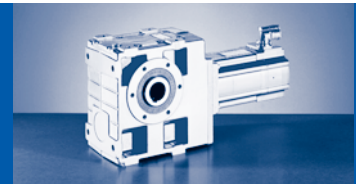

GSS□□-3S HAK

	o	o ₁	p	p ₂	h	h ₁	a	q	k ₈
GSS05...	209	174	205	65	125	80	13	103.5	40
GSS06...	252	203 ¹⁾ 202 ²⁾	250	63	150	100	10	122.5 ¹⁾ 121.5 ²⁾	50 ¹⁾ 49 ²⁾
GSS07...	299	256	310	73	190	120	12	155.5	66

¹⁾ a₂ = 200
²⁾ a₂ = 250

	d	l	d ₁	l ₁	u	t	a ₂	b ₂	c ₂	e ₂	f ₂	i ₂	s ₂
	H7				JS9	+0,2		j7					
GSS05...	30	140	50	124	8	33.3	200	130	12	165	3.5	33.5	4 x 11
	35				10	38.3						42.5	
GSS06...	40	160	65	140	12	43.3	250	180	15	215	4	41.5	4 x 14
	45				14	48.8						55.5	
GSS07...	50	200	75	175	14	53.8	300	230	17	265	4	55.5	4 x 14
	55				16	59.3							

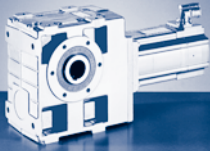

GSS [mm]

GSS□□-3S (MCS)

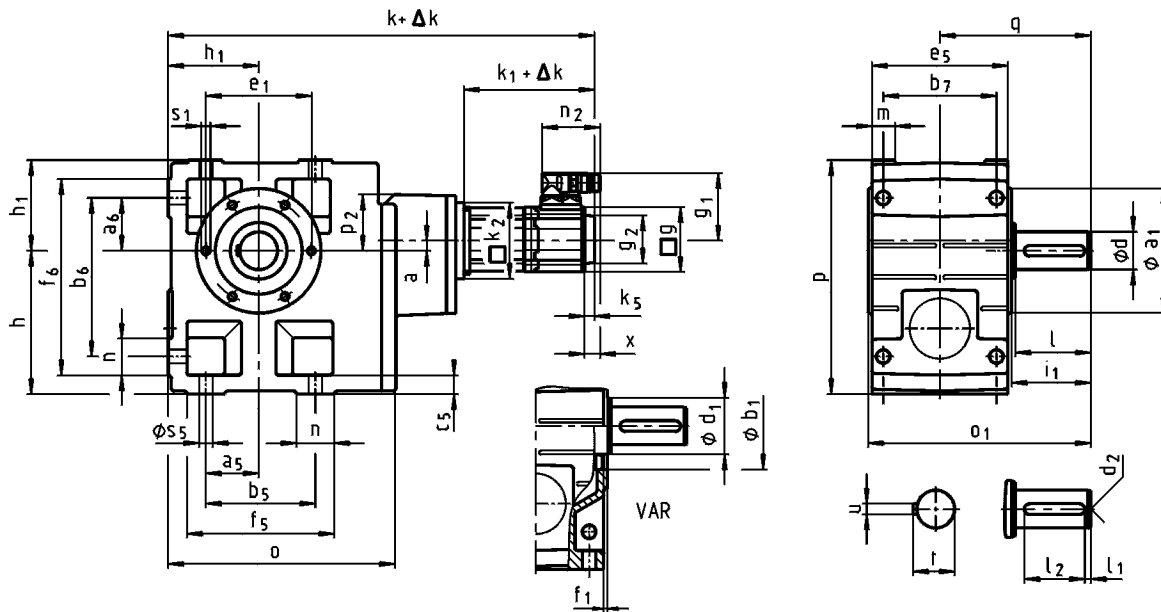

GSS□□-3S V□R ... RSO

		06C C41	06F C41	06I C41	09D C41	09F C38	09H C41	09L C41	12D C20	12D C41	12H C15	12H C30	12H C35	12L C20	12L C41	
GSS05...	k	423	453	483	476	496	516	556								
GSS06...	k	480	510	540	533	553	573	613								
GSS07...	k	534	564	594	587	607	627	667	604		644			684		
...RSO B0 ¹⁾	Δk	0														
...RSO P□ ¹⁾	Δk	19				20										
	k_1	132	162	192	183	203	223	263	188			228			268	
	k_2	66			91							118	145 ²⁾			
	g	62				89						116				
...RSO	k_5	0				13						14				
	g_2	□ 62			Ø 67						Ø 72					
	g_1	76				90						105				
	n_2	64								78						
	x					21						18				

¹⁾ → 801 - SRS/SRM/ECN/EQN/EQI/C20

²⁾ GSS07: 12DC20 ... 12LC41

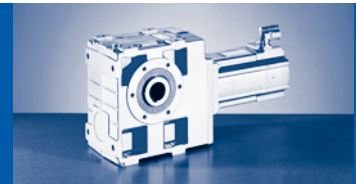

GSS□□-3S V□R

	o	o ₁	p	p ₂	h	h ₁	a	q	a ₅	a ₆	b ₅	b ₆	b ₇	c ₅	e ₅	f ₅	f ₆	m	n	s ₅
GSS05...	209	197	205	65	125	80	13	130	47.5	47.5	95	140	105	17	127	124	169	21	29	11
GSS06...	252	236	250	63	150	100	10	160	60	60	120	170	120	20	145	156	206	23	36	14
GSS07...	299	296	310	73	190	120	12	200	70	70	140	210	150	25	180	185	255	28	45	18

	d	l	d ₁	l ₁	l ₂	d ₂	u	t	a ₁	b ₁	e ₁	f ₁	i ₁	s ₁
										H7				6x60°
GSS05...	30	60	50	6	45	M10	8	33	118	80	100	4	64	M8x15
GSS06...	40	80	65	7	63	M16	12	43	140	100	120		85	M10x16
GSS07...	50	100	75	8	80		14	53.5	165	115	140	5	105	M12x18

d ≤ 50 mm: k6; d > 50 mm: m6

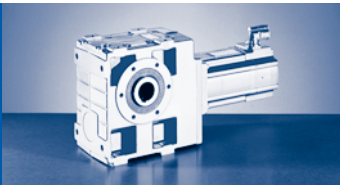

GSS [mm]

GSS□□-3S (MCS)

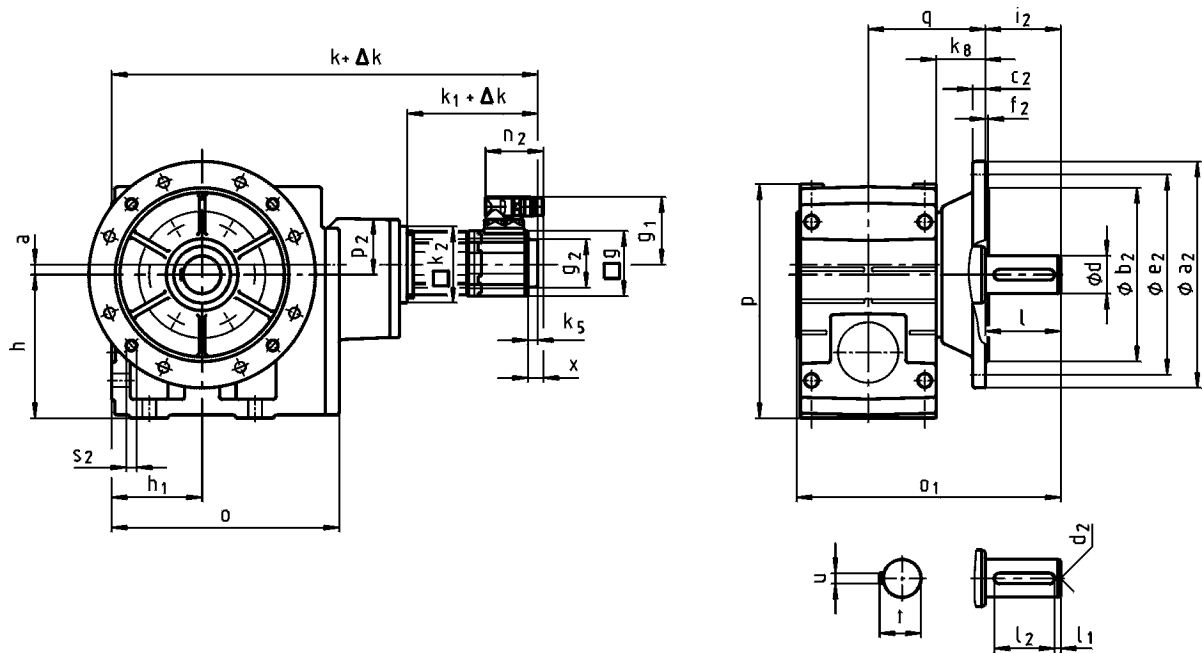

GSS□□-3S VAK ... RSO

		06C C41	06F C41	06I C41	09D C41	09F C38	09H C41	09L C41	12D C20	12D C41	12H C15	12H C30	12H C35	12L C20	12L C41
GSS05...	k	423	453	483	476	496	516	556							
GSS06...	k	480	510	540	533	553	573	613							
GSS07...	k	534	564	594	587	607	627	667	604		644			684	
...RSO B0 ¹⁾	Δk	0													
...RSO P□ ²⁾	Δk	19				20									
...RSO	k_1	132	162	192	183	203	223	263	188		228			268	
	k_2	66			91				118				145 ²⁾		
	g	62			89				116						
	k_5	0			13				14						
	g_2	□ 62			Ø 67				Ø 72						
	g_1	76			90				105						
	n_2	64							78						
	x				21				18						

¹⁾ → 801 - SRS/SRM/ECN/EQN/EQI/C20

²⁾ GSS07: 12DC20 ... 12LC41

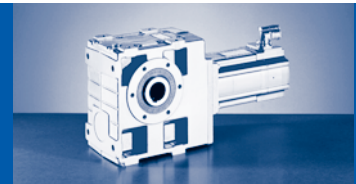

GSS□□-3S VAK

	o	o ₁	p	p ₂	h	h ₁	a	q	k ₈
GSS05...	209	230	205	65	125	80	13	103.5	40
GSS06...	252	277	250	63	150	100	10	121.5	49
GSS07...	299	351	310	73	190	120	12	155.5	66

	d	l	l ₁	l ₂	d ₂	u	t	a ₂	b ₂	c ₂	e ₂	f ₂	i ₂	s ₂
GSS05...	30	60	6	45	M10	8	33	200	130	12	165	3.5	60	4 x 11
GSS06...	40	80	7	63	M16	12	43	250	180	15	215	4	80	4 x 14
GSS07...	50	100	8	80		14	53.5	300	230	17	265		100	

d ≤ 50 mm: k6; d > 50 mm: m6

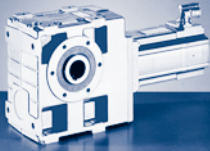

GSS [mm]

GSS□□-2A (MCA)

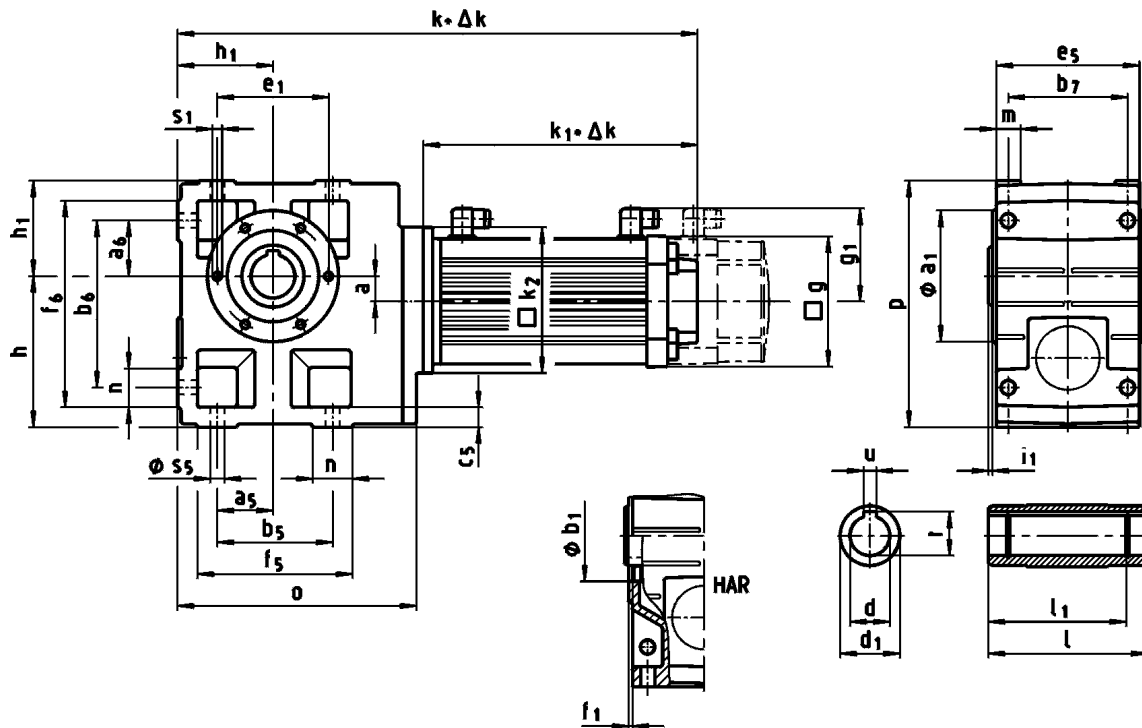

GSS□□-2A H□□ ... RSO

		10I C40 ...S00	13I C41 ...S00	13I C34 ...F10	14L C20 ...S00	14L C41 ...S00	14L C16 ...F10	14L C35 ...F10	17N C23 ...S00	17N C41 ...S00
GSS04...	k	453	462	530						
GSS05...	k	475	483	551	533		595			
GSS06...	k	515	523	591	573		635		612	
GSS07...	k	558	566	634	616		678		655	
...RSO B0 ¹⁾	Δk	0								
...RSO P□ ¹⁾	Δk	25	35			33			35	
	k_1	258	267	335	307		369		346	
	k_2	145				180				
	g	102	131			142			165	
	g_1	90	102			109			118	

¹⁾ → 803 - SRS/SRM/ECN/EQN/EQI/S20/T20/CDD

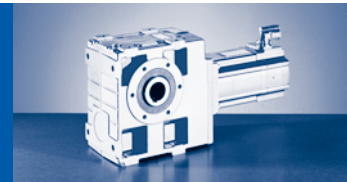

GSS□□-2A H□R ... RSO

		17N C17 ...F10	17N C35 ...F10	19S C23 ...S00	19S C42 ...S00	19S C17 ...F10	19S C35 ...F10	21X C25 ...S00	21X C42 ...S00	21X C17 ...F10	21X C35 ...F10
GSS06...	k	701									
GSS07...	k	744		724		821		802		898	
...RSO B0 ¹⁾	Δk	0									
...RSO P□ ¹⁾	Δk	35		38				42			
	k ₁	435		408		505		479		575	
	k ₂	180				222				265	
	g	165				192				214	
	g ₁	118				161				172	

¹⁾ →  803 - SRS/SRM/ECN/EQN/EQI/S20/T20/CDD

GSS□□-2A H□R

	o	p	h	h ₁	a	a ₅	a ₆	b ₅	b ₆	b ₇	c ₅	e ₅	f ₅	f ₆	m	n	s ₅
GSS04...	181	171	100	71	20	45	45	90	119	85	14	100	112	141	20	22	9
GSS05...	212	205	125	80	23	47.5	47.5	95	140	105	17	127	124	169	21	29	11
GSS06...	255	250	150	100	26	60	60	120	170	120	20	145	156	206	23	36	14
GSS07...	305	310	190	120	33	70	70	140	210	150	25	180	185	255	28	45	18

	d	l	d ₁	l ₁	u	t	a ₁	b ₁	e ₁	f ₁	i ₁	s ₁
	H7				JS9	+0,2		H7				6x60°
GSS04...	25	115	45	100	8	28.3	105	75	90	3	2.5	M6x12
	30					33.3						
GSS05...	35	140	50	124	10	38.3	118	80	100	4	4	M8x15
	40					43.3						
GSS06...	45	160	65	140	14	48.8	140	100	120	5	5	M10x16
	50					53.8						
GSS07...	55	200	75	175	16	59.3	165	115	140	5	5	M12x18

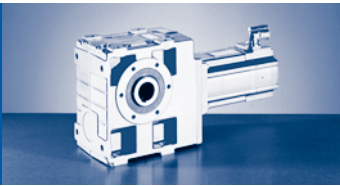

GSS [mm]

GSS□□-2A (MCA)

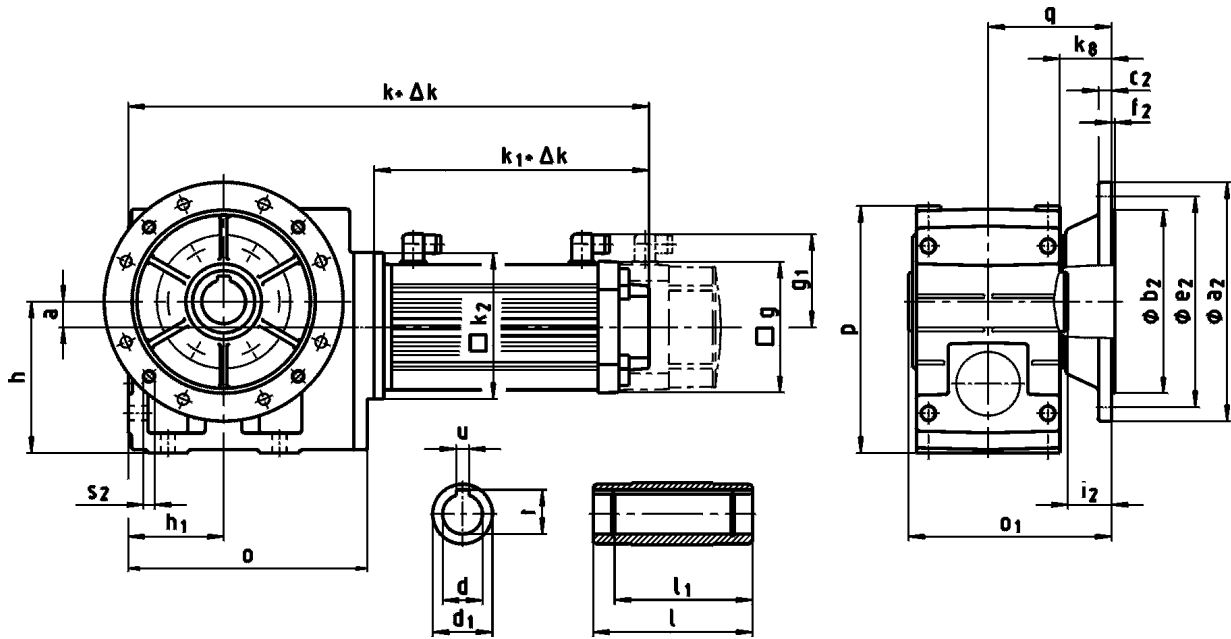

GSS□□-2A HAK ... RSO

		10L C40 ...S00	13L C41 ...S00	13L C34 ...F10	14L C20 ...S00	14L C41 ...S00	14L C16 ...F10	14L C35 ...F10	17N C23 ...S00	17N C41 ...S00
GSS04...	k	453	462	530						
GSS05...	k	475	483	551	533		595			
GSS06...	k	515	523	591	573		635		612	
GSS07...	k	558	566	634	616		678		655	
...RSO B0 ¹⁾	Δk	0								
...RSO P□ ¹⁾	Δk	25	35			33			35	
	k_1	258	267	335	307		369		346	
	k_2	145				180				
	g	102	131			142			165	
	g_1	90	102			109			118	

¹⁾ → 803 - SRS/SRM/ECN/EQN/EQI/S20/T20/CDD

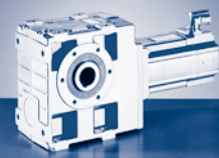

GSS□□-2A HAK ... RSO

		17N C17 ...F10	17N C35 ...F10	19S C23 ...S00	19S C42 ...S00	19S C17 ...F10	19S C35 ...F10	21X C25 ...S00	21X C42 ...S00	21X C17 ...F10	21X C35 ...F10
GSS06...	k	701									
GSS07...	k	744		724		821		802		898	
...RSO B0 ¹⁾	Δ k	0									
...RSO P□ ¹⁾	Δ k	35		38				42			
	k ₁	435		408		505		479		575	
	k ₂	180		222				265			
	g	165		192				214			
	g ₁	118		161				172			

¹⁾ → 803 - SRS/SRM/ECN/EQN/EQI/S20/T20/CDD

GSS□□-2A HAK

	o	o ₁	p	h	h ₁	a	q	k _g
GSS04...	181	149	171	100	71	20	91	41
GSS05...	212	174	205	125	80	23	103.5	40
GSS06...	255	203 ²⁾ 202 ³⁾	250	150	100	26	122.5 ²⁾ 121.5 ³⁾	50 ²⁾ 49 ³⁾
GSS07...	305	256	310	190	120	33	155.5	66

²⁾ a₂ = 200

³⁾ a₂ = 250

	d	l	d ₁	l ₁	u	t	a ₂	b ₂	c ₂	e ₂	f ₂	i ₂	s ₂
	H7				JS9	+0,2		j7					
GSS04...	25	115	45	100	8	28.3	160	110	10	130	3.5	33.5	4 x 9
	30					33.3							
GSS05...	35	140	50	124	10	38.3	200	130	12	165	3.5	33.5	4 x 11
	40					43.3							
GSS06...	45	160	65	140	14	48.8	250	180	15	215	4	41.5	4 x 14
	50					53.8							
GSS07...	55	200	75	175	16	59.3	300	230	17	265	4	55.5	4 x 14

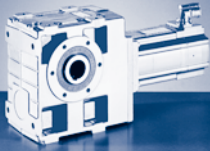

GSS [mm]

GSS□□-2A (MCA)

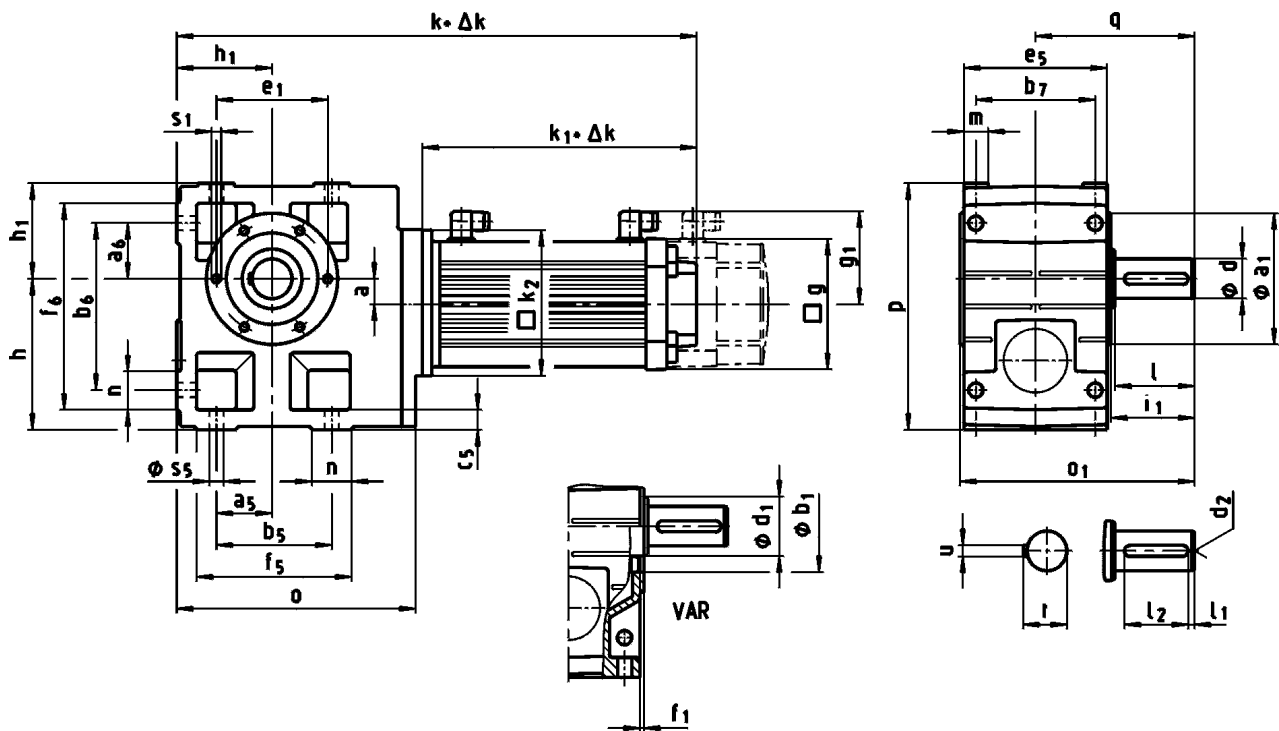

GSS□□-2A V□□ ... RSO

		10I C40 ...S00	13I C41 ...S00	13I C34 ...F10	14L C20 ...S00	14L C41 ...S00	14L C16 ...F10	14L C35 ...F10	17N C23 ...S00	17N C41 ...S00
GSS04...	k	453	462	530						
GSS05...	k	475	483	551	533		595			
GSS06...	k	515	523	591	573		635		612	
GSS07...	k	558	566	634	616		678		655	
...RSO B0 ¹⁾	Δk	0								
...RSO P□ ¹⁾	Δk	25	35			33			35	
	k_1	258	267	335	307		369		346	
	k_2	145				180				
	g	102	131			142			165	
	g_1	90	102			109			118	

¹⁾ → 803 - SRS/SRM/ECN/EQN/EQI/S20/T20/CDD

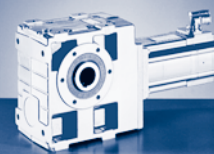

GSS□□-2A V□R ... RSO

		17N C17 ...F10	17N C35 ...F10	19S C23 ...S00	19S C42 ...S00	19S C17 ...F10	19S C35 ...F10	21X C25 ...S00	21X C42 ...S00	21X C17 ...F10	21X C35 ...F10
GSS06...	k	701									
GSS07...	k	744		724		821		802		898	
...RSO B0 ¹⁾	Δ k	0									
...RSO P□ ¹⁾	Δ k	35		38				42			
	k ₁	435		408		505		479		575	
	k ₂	180		222				265			
	g	165		192				214			
	g ₁	118		161				172			

¹⁾ →  803 - SRS/SRM/ECN/EQN/EQI/S20/T20/CDD

GSS□□-2A V□R

	o	o ₁	p	h	h ₁	a	q	a ₅	a ₆	b ₅	b ₆	b ₇	c ₅	e ₅	f ₅	f ₆	m	n	s ₅
GSS04...	181	163	171	100	71	20	107.5	45	45	90	119	85	14	100	112	141	20	22	9
GSS05...	212	197	205	125	80	23	130	47.5	47.5	95	140	105	17	127	124	169	21	29	11
GSS06...	255	236	250	150	100	26	160	60	60	120	170	120	20	145	156	206	23	36	14
GSS07...	305	296	310	190	120	33	200	70	70	140	210	150	25	180	185	255	28	45	18

	d	l	d ₁	l ₁	l ₂	d ₂	u	t	a ₁	b ₁	e ₁	f ₁	i ₁	s ₁
										H7				6x60°
GSS04...	25	50	45	4	40	M10	8	28	105	75	90	3	52.5	M6x12
GSS05...	30	60	50	6	45			33	118	80	100	4	64	M8x15
GSS06...	40	80	65	7	63	M16	14	43	140	100	120		85	M10x16
GSS07...	50	100	75	8	80			53.5	165	115	140	5	105	M12x18

d ≤ 50 mm: k6; d > 50 mm: m6

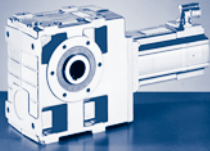

GSS [mm]

GSS□□-2A (MCA)

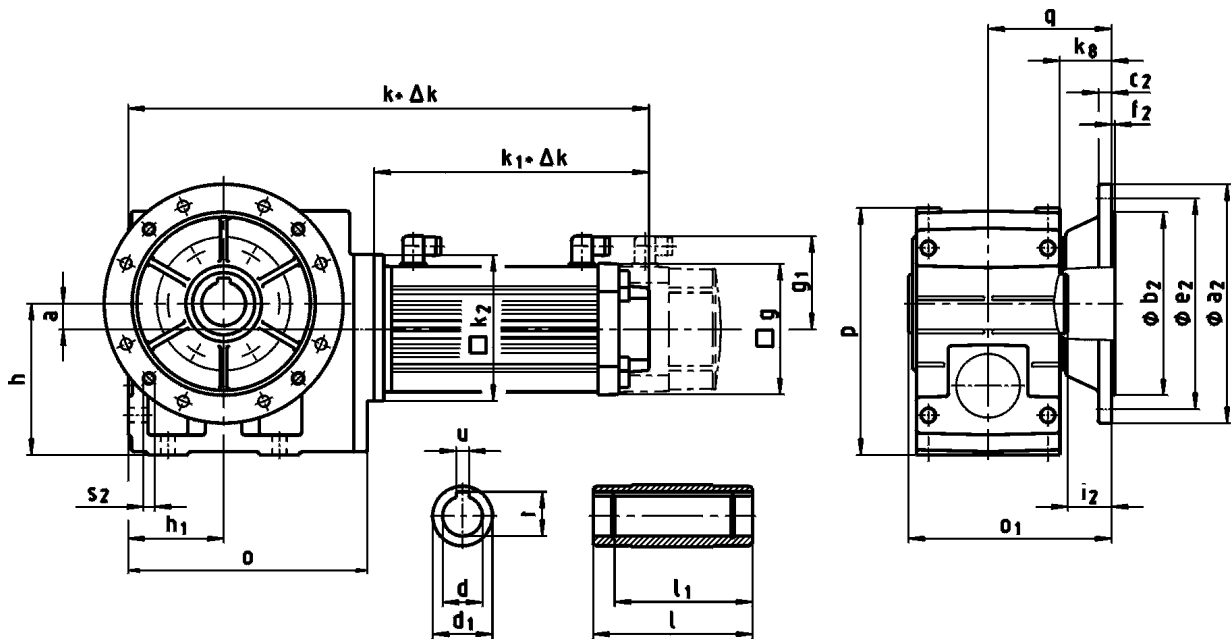

GSS□□-2A VAK ... RSO

		10I C40 ...S00	13I C41 ...S00	13I C34 ...F10	14L C20 ...S00	14L C41 ...S00	14L C16 ...F10	14L C35 ...F10	17N C23 ...S00	17N C41 ...S00
GSS04...	k	453	462	530						
GSS05...	k	475	483	551	533		595			
GSS06...	k	515	523	591	573		635		612	
GSS07...	k	558	566	634	616		678		655	
...RSO B0 ¹⁾	Δk	0								
...RSO P□ ¹⁾	Δk	25	35			33			35	
	k_1	258	267	335	307		369		346	
	k_2	145				180				
	g	102	131			142			165	
	g ₁	90	102			109			118	

¹⁾ → 803 - SRS/SRM/ECN/EQN/EQI/S20/T20/CDD

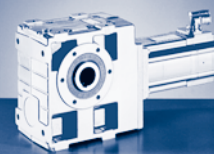

GSS□□-2A VAK ... RSO

		17N C17 ...F10	17N C35 ...F10	19S C23 ...S00	19S C42 ...S00	19S C17 ...F10	19S C35 ...F10	21X C25 ...S00	21X C42 ...S00	21X C17 ...F10	21X C35 ...F10
GSS06...	k	701									
GSS07...	k	744		724		821		802		898	
...RSO B0 ¹⁾	Δk	0									
...RSO P□ ¹⁾	Δk	35		38				42			
	k ₁	435		408		505		479		575	
	k ₂	180		222				265			
	g	165		192				214			
	g ₁	118		161				172			

¹⁾ →  803 - SRS/SRM/ECN/EQN/EQI/S20/T20/CDD

GSS□□-2A VAK

	o	o ₁	p	h	h ₁	a	q	k ₈
GSS04...	181	196	171	100	71	20	91	41
GSS05...	212	230	205	125	80	23	103.5	40
GSS06...	255	277	250	150	100	26	121.5	49
GSS07...	305	351	310	190	120	33	155.5	66

	d	l	l ₁	l ₂	d ₂	u	t	a ₂	b ₂	c ₂	e ₂	f ₂	i ₂	s ₂
GSS04...	25	50	4	40	M10	8	28	160	110	10	130	3.5	50	4 x 9
GSS05...	30	60	6	45			33	200	130	12	165		60	4 x 11
GSS06...	40	80	7	63	M16	14	43	250	180	15	215	4	80	4 x 14
GSS07...	50	100	8	80			53.5						300	

d ≤ 50 mm: k6; d > 50 mm: m6

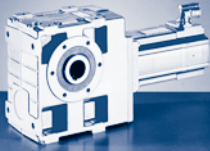

GSS [mm]

GSS□□-3A (MCA)

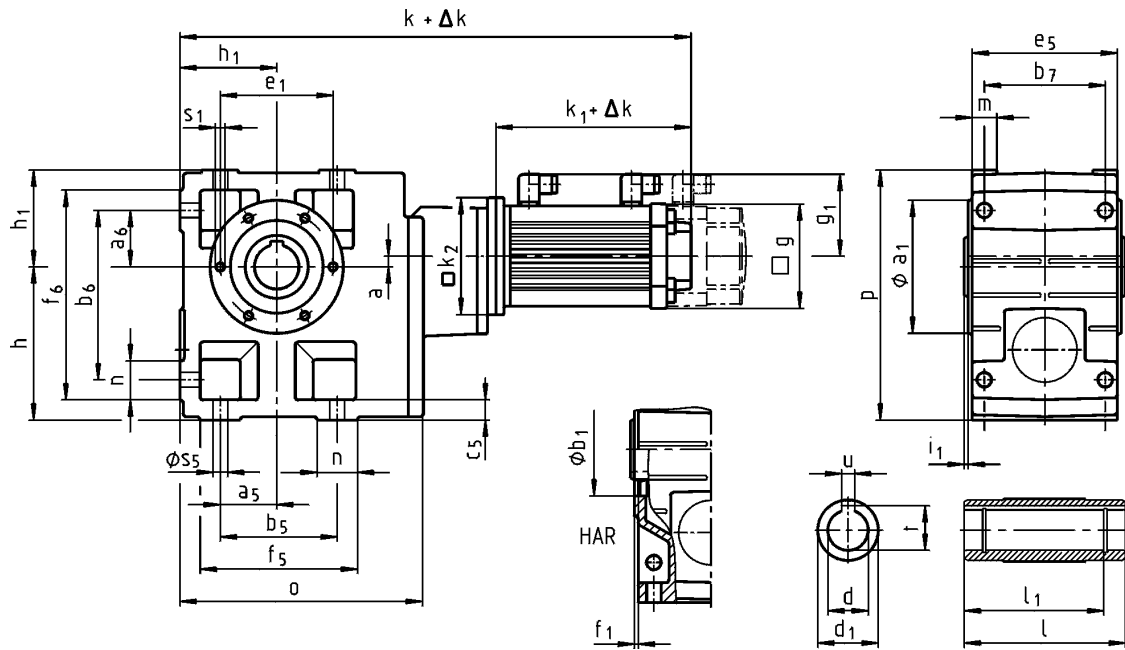

GSS□□-3A H□R ... RSO

		10I C40 ...S00	13I C41 ...S00	13I C34 ...F10	14L C20 ...S00	14L C41 ...S00	14L C16 ...F10	14L C35 ...F10
GSS05...	k	551	560	628				
GSS06...	k	608	617	685				
GSS07...	k	662	671	739		721		783
...RSO B0 ¹⁾	Δk	0						
...RSO P□ ¹⁾	Δk	25		35			33	
	k_1	258	267	335		307		369
	k_2		145				180	
	g	102		131			142	
	g_1	90		102			109	

¹⁾ → 803 - SRS/SRM/ECN/EQN/EQI/S20/T20/CDD

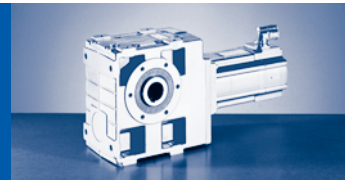

GSS□□-3A H□R

	o	p	h	h ₁	a	a ₅	a ₆	b ₅	b ₆	b ₇	c ₅	e ₅	f ₅	f ₆	m	n	s ₅
GSS05...	209	205	125	80	13	47.5	47.5	95	140	105	17	127	124	169	21	29	11
GSS06...	252	250	150	100	10	60	60	120	170	120	20	145	156	206	23	36	14
GSS07...	299	310	190	120	12	70	70	140	210	150	25	180	185	255	28	45	18

	d	l	d ₁	l ₁	u	t	a ₁	b ₁	e ₁	f ₁	i ₁	s ₁
	H7				JS9	+0,2		H7				6x60°
GSS05...	30	140	50	124	8	33.3	118	80	100	4	4	M8x15
	35				10	38.3						
GSS06...	40	160	65	140	12	43.3	140	100	120		5	M10x16
	45				14	48.8						
GSS07...	50	200	75	175	14	53.8	165	115	140	5	M12x18	
	55				16	59.3						

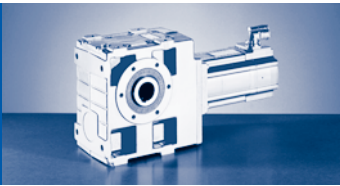

GSS [mm]

GSS□□-3A (MCA)

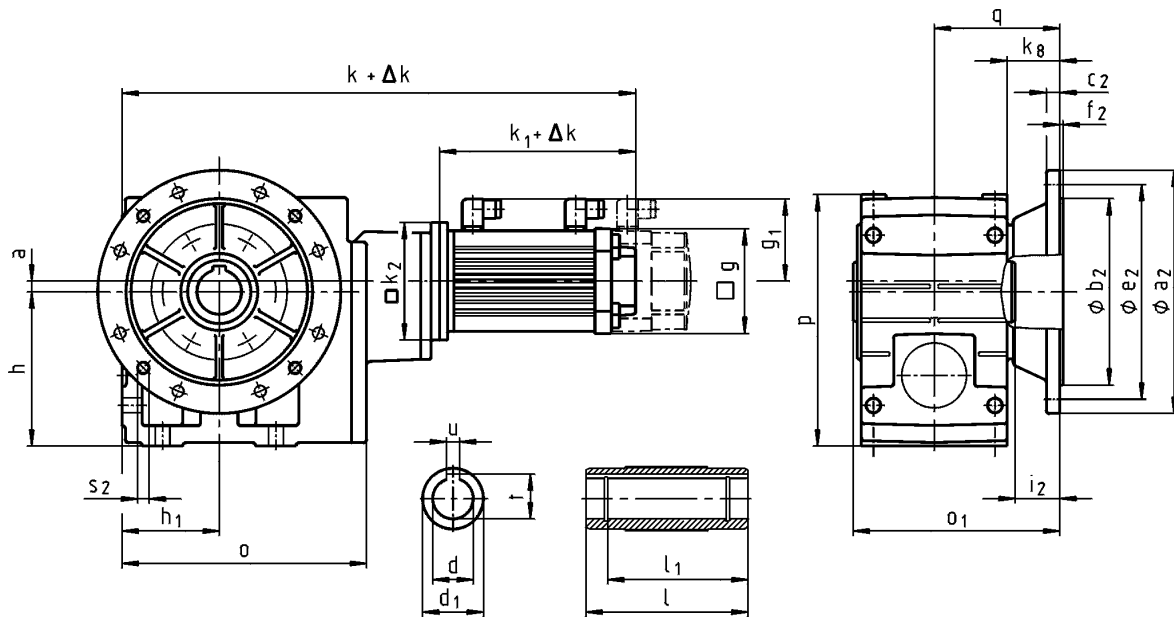

GSS□□-3A HAK ... RSO

		10I C40 ...S00	13I C41 ...S00	13I C34 ...F10	14L C20 ...S00	14L C41 ...S00	14L C16 ...F10	14L C35 ...F10
GSS05...	k	551	560	628				
GSS06...	k	608	617	685				
GSS07...	k	662	671	739		721		783
...RSO B0 ¹⁾	Δk	0						
...RSO P□ ¹⁾	Δk	25		35			33	
	k_1	258	267	335		307		369
	k_2		145				180	
	g	102		131			142	
	g_1	90		102			109	

¹⁾ → 803 - SRS/SRM/ECN/EQN/EQI/S20/T20/CDD

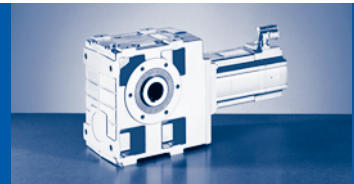

GSS□□-3A HAK

	o	o ₁	p	h	h ₁	a	q	k ₈
GSS05...	209	174	205	125	80	13	103.5	40
GSS06...	252	203 ¹⁾ 202 ²⁾	250	150	100	10	122.5 ¹⁾ 121.5 ²⁾	50 ¹⁾ 49 ²⁾
GSS07...	299	256	310	190	120	12	155.5	66

¹⁾ a₂ = 200

²⁾ a₂ = 250

	d	l	d ₁	l ₁	u	t	a ₂	b ₂	c ₂	e ₂	f ₂	i ₂	s ₂
	H7				JS9	+0,2		j7					
GSS05...	30	140	50	124	8	33.3	200	130	12	165	3.5	33.5	4 x 11
	35				10	38.3						42.5	
GSS06...	40	160	65	140	12	43.3	250	180	15	215	4	41.5	4 x 14
	45				14	48.8						55.5	
GSS07...	50	200	75	175	14	53.8	300	230	17	265	4	55.5	4 x 14
	55				16	59.3							

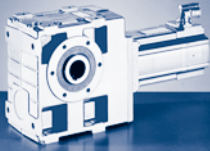

GSS [mm]

GSS□□-3A (MCA)

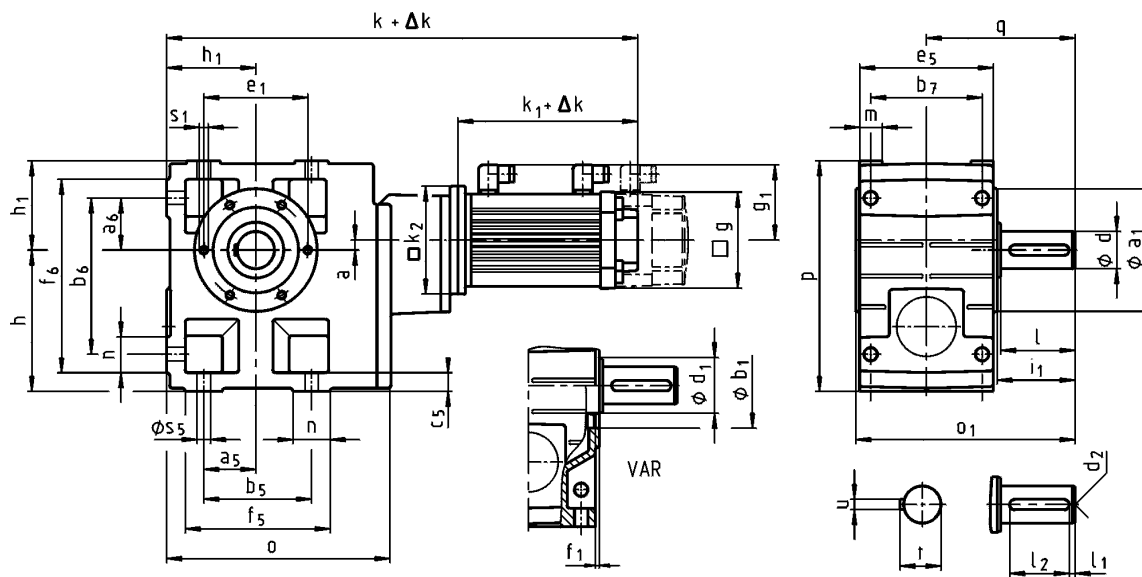

GSS□□-3A V□R ... RSO

		10L C40 ...S00	13L C41 ...S00	13L C34 ...F10	14L C20 ...S00	14L C41 ...S00	14L C16 ...F10	14L C35 ...F10
GSS05...	k	551	560	628				
GSS06...	k	608	617	685				
GSS07...	k	662	671	739		721		783
...RSO B0 ¹⁾	Δk				0			
...RSO P□ ¹⁾	Δk	25	35				33	
	k_1	258	267	335		307		369
	k_2		145				180	
	g	102		131			142	
	g_1	90		102			109	

¹⁾ → 803 - SRS/SRM/ECN/EQN/EQI/S20/T20/CDD

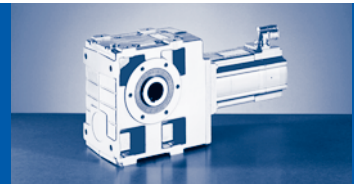

GSS□□-3A V□R

	o	o ₁	p	h	h ₁	a	q	a ₅	a ₆	b ₅	b ₆	b ₇	c ₅	e ₅	f ₅	f ₆	m	n	s ₅
GSS05...	209	197	205	125	80	13	130	47.5	47.5	95	140	105	17	127	124	169	21	29	11
GSS06...	252	236	250	150	100	10	160	60	60	120	170	120	20	145	156	206	23	36	14
GSS07...	299	296	310	190	120	12	200	70	70	140	210	150	25	180	185	255	28	45	18

	d	l	d ₁	l ₁	l ₂	d ₂	u	t	a ₁	b ₁	e ₁	f ₁	i ₁	s ₁
										H7				6x60°
GSS05...	30	60	50	6	45	M10	8	33	118	80	100	4	64	M8x15
GSS06...	40	80	65	7	63	M16	12	43	140	100	120		85	M10x16
GSS07...	50	100	75	8	80		14	53.5	165	115	140	5	105	M12x18

d ≤ 50 mm: k6; d > 50 mm: m6

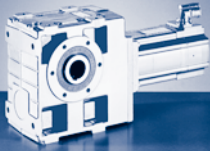

GSS [mm]

GSS□□-3A (MCA)

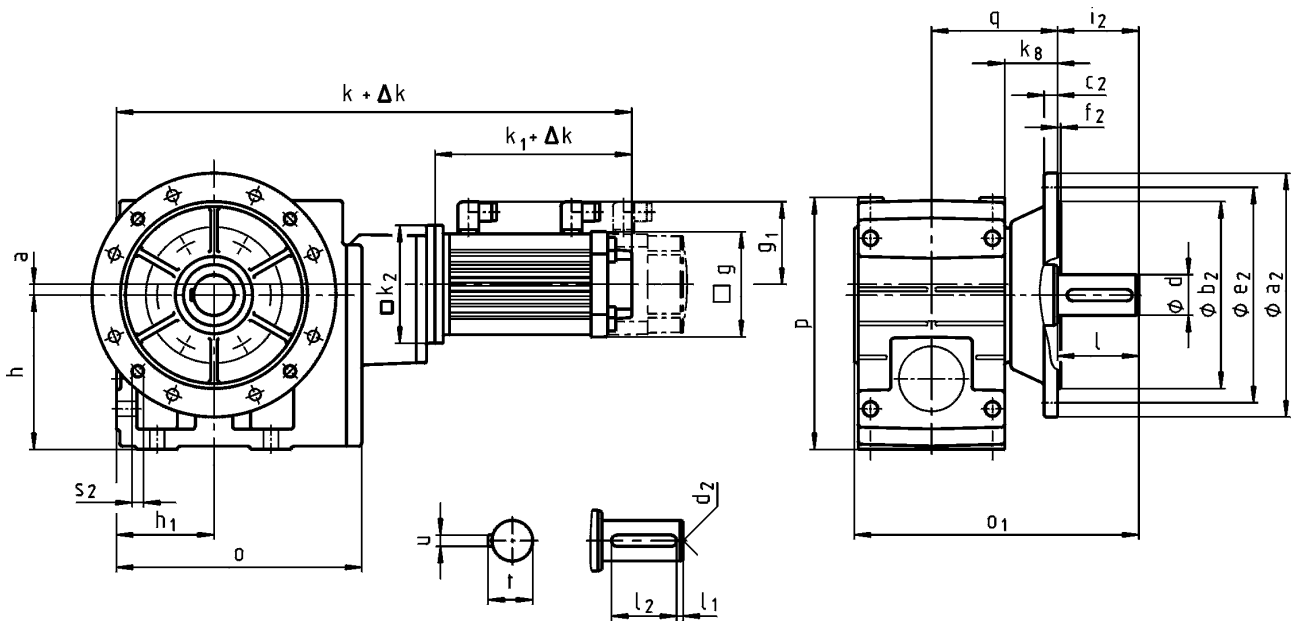

GSS□□-3A VAK ... RSO

		10L C40 ...S00	13L C41 ...S00	13L C34 ...F10	14L C20 ...S00	14L C41 ...S00	14L C16 ...F10	14L C35 ...F10
GSS05...	k	551	560	628				
GSS06...	k	608	617	685				
GSS07...	k	662	671	739	721		783	
...RSO B0 ¹⁾	Δk	0						
...RSO P□ ¹⁾	Δk	25	35			33		
	k_1	258	267	335	307		369	
	k_2	145				180		
	g	102	131			142		
	g_1	90	102			109		

¹⁾ → 803 - SRS/SRM/ECN/EQN/EQI/S20/T20/CDD

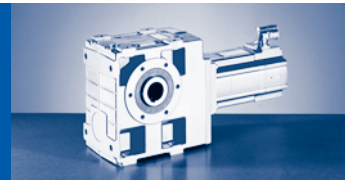

GSS□□-3A VAK

	o	o ₁	p	h	h ₁	a	q	k ₈
GSS05...	209	230	205	125	80	13	103.5	40
GSS06...	252	277	250	150	100	10	121.5	49
GSS07...	299	351	310	190	120	12	155.5	66

	d	l	l ₁	l ₂	d ₂	u	t	a ₂	b ₂	c ₂	e ₂	f ₂	i ₂	s ₂
GSS05...	30	60	6	45	M10	8	33	200	130	12	165	3.5	60	4 x 11
GSS06...	40	80	7	63	M16	12	43	250	180	15	215	4	80	4 x 14
GSS07...	50	100	8	80		14	53.5	300	230	17	265		100	

d ≤ 50 mm: k6; d > 50 mm: m6

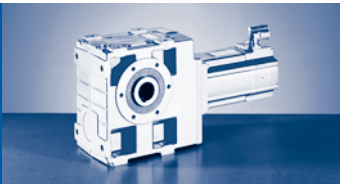

Hollow shaft with shrink disc

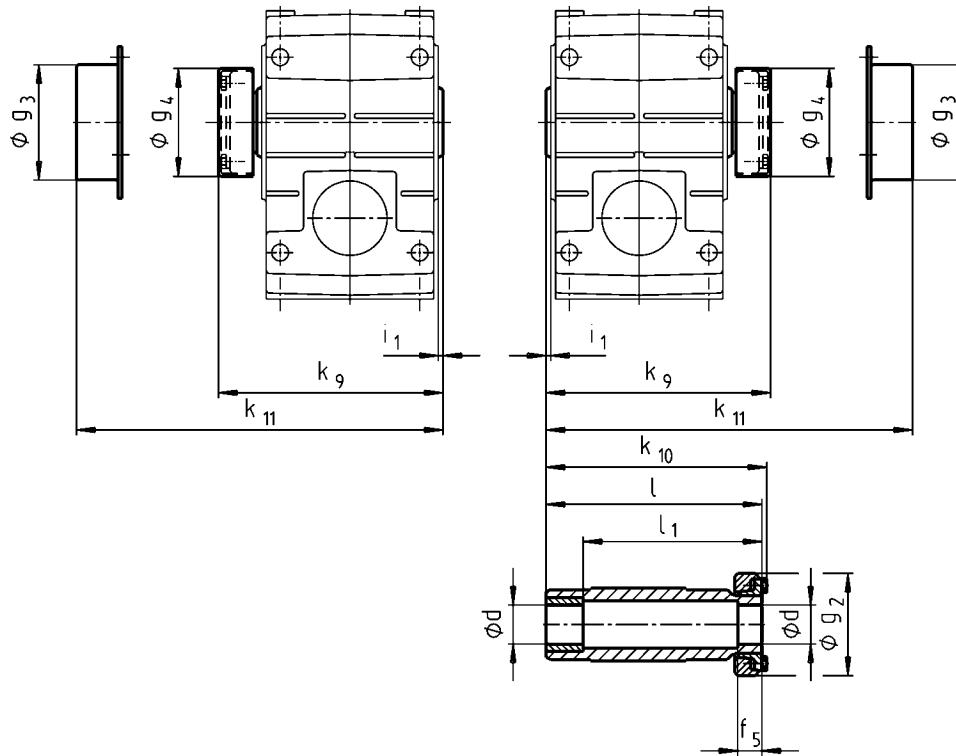

	Machine shaft	Hollow shaft with shrink disc						Protective cap		Cover	
	d	i ₁	k ₁₀	g ₂	l	l ₁	f ₅	k ₉	g ₄	k ₁₁	g ₃
	h6										
GSS04...	25 30	2.5	148	72	142	122	26	150	76	154	79
GSS05...	35	4	174	80	168	148	28	176	84	179	90
GSS06...	40	5	200	90	194	164	30	202	94	204	100
GSS07...	50		238	110	232	192	26	241	116	244	124

- ▶ Ensure that the strength of the shaft material is adequate in shrink disc designs.
When using typical steels (e.g. C45, 42CrMo4), the torques listed in the selection tables can be used without restriction. When using material that is considerably weaker, please consult us. Medium surface roughness Rz must not exceed 15 µm (turning operation is sufficient).

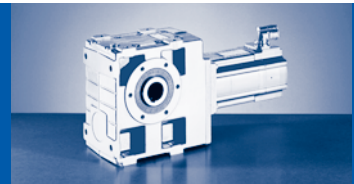

Hoseproof hollow shaft cover

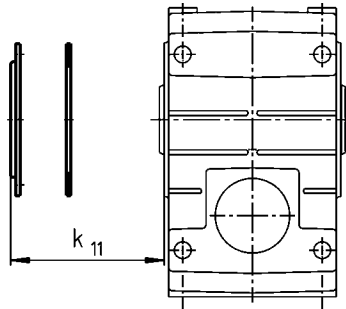

	Cover including seal
	k_{11}
GSS04...	9
GSS05...	10
GSS06...	11
GSS07...	

Gearbox with 2nd output shaft end

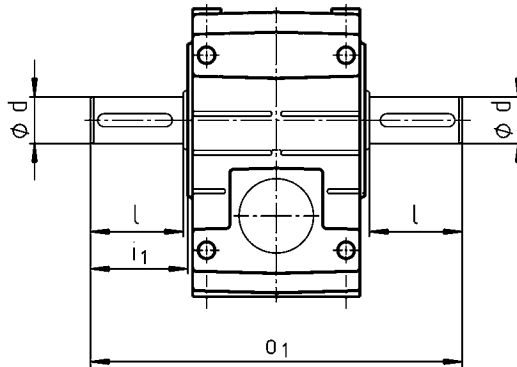

	d	l	i_1	o_1
GSS04...	25	50	52.5	215
GSS05...	30	60	64	260
GSS06...	40	80	85	320
GSS07...	50	100	105	400

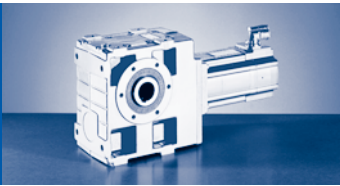

GSS & [mm]

Torque plate at threaded pitch circle in position 3

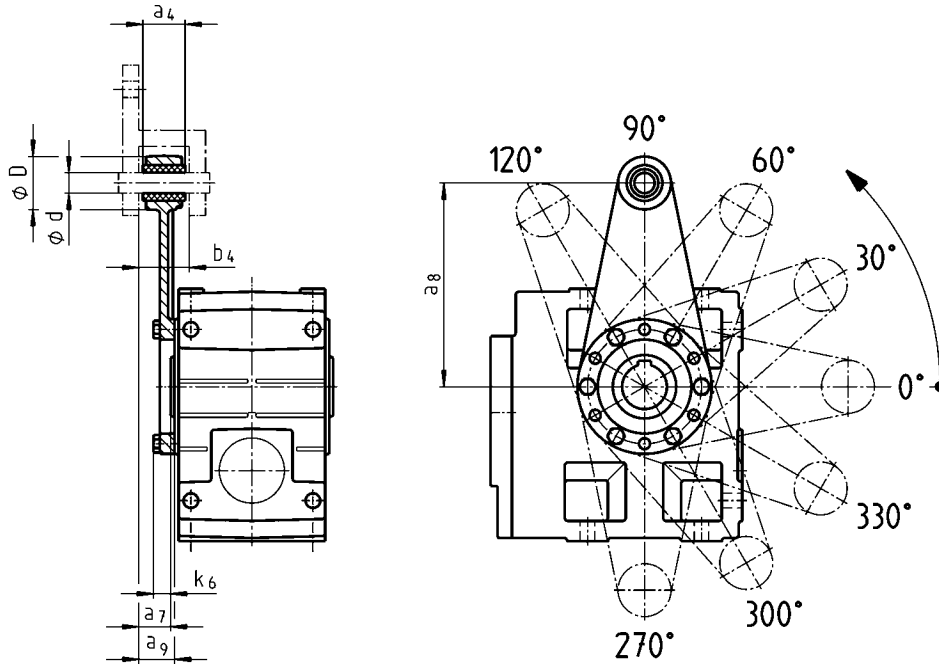

Torque plate at threaded pitch circle in position 5

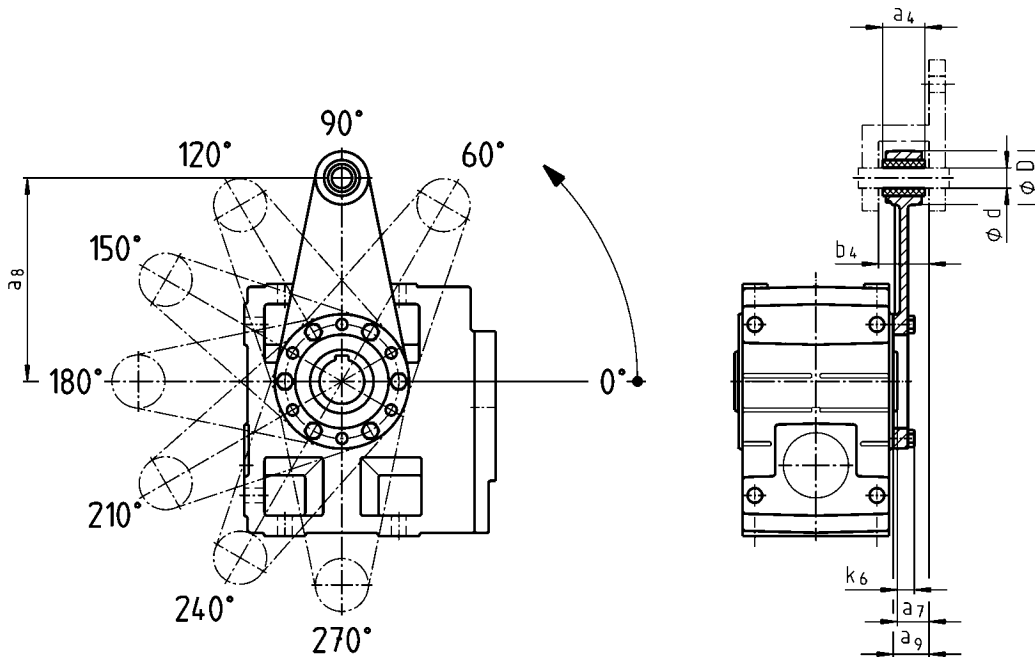

	Installation space							
	a ₇	b ₄	a ₄	a ₈	a ₉	d	D	k ₆
GSS04...	24	34.5	30	130	26.5	12	35	16
GSS05...	23.5	38.5	34	160	27.5	16	45	15
GSS06...	28	44.5	40	200	33	20	50	18
GSS07...	32.5	50.5	46	250	37.5	25	65	21

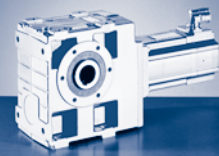

Torque plate at casing foot in position 2, 4 or 6

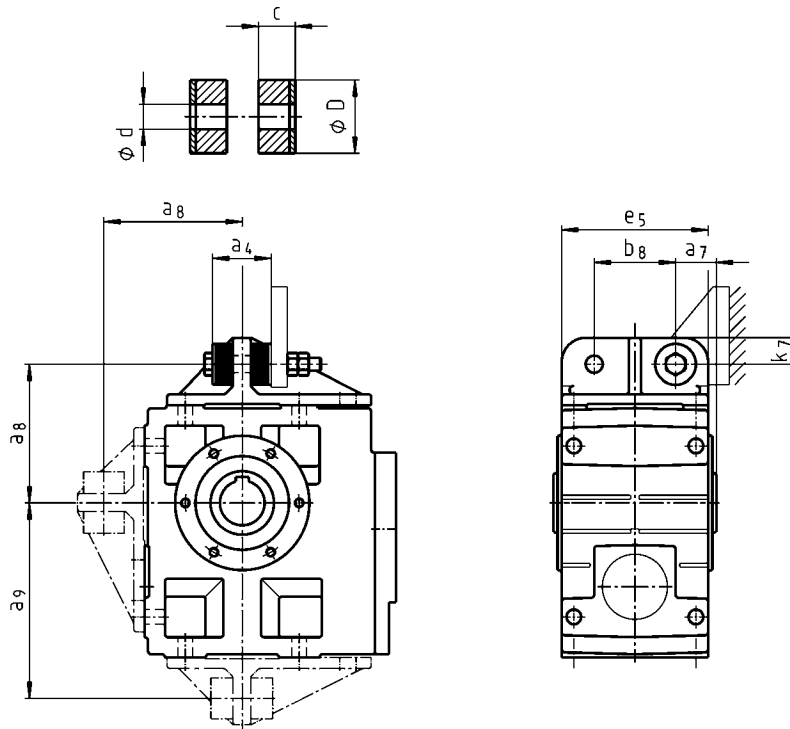

	a_4	a_7	a_8	a_9	b_8	c	d	D	e_5	k_7
GSS04...	41	27.5	106	135	60	14.5	11	30	100	20
GSS05...	45	35	115	160	70	15	13	40	127	25
GSS06...	72	40	145	195	80	27	17	50	145	28
GSS07...	78	50	170	240	100	28	21	60	180	35

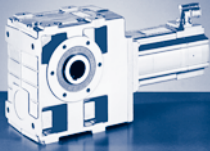

GSS & [mm]

Mounting set for hollow shaft circlip Proposed design for auxiliary tools

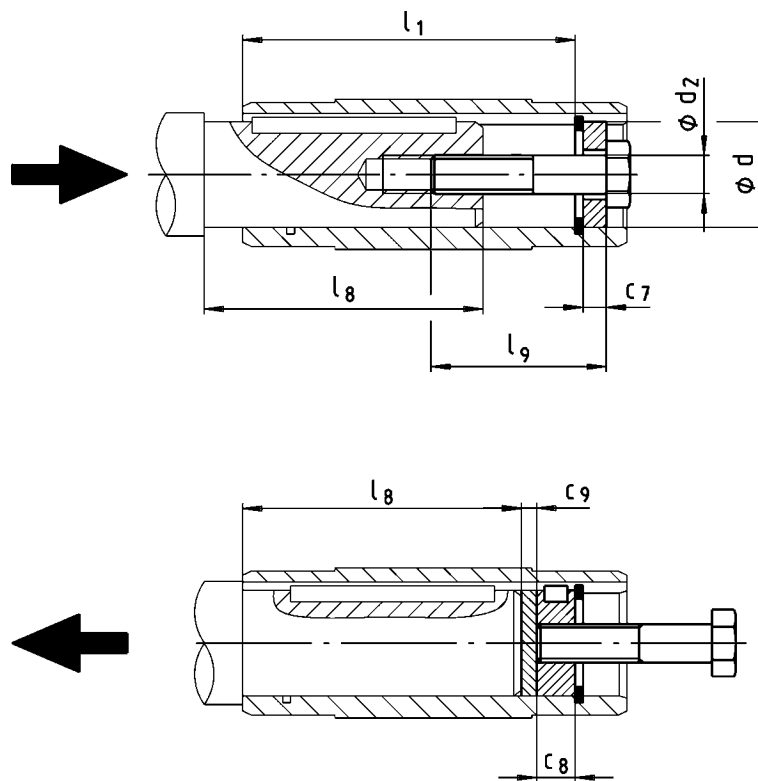

	Hollow shaft		Hollow shaft circlip mounting set (Assembly auxiliaries)			Auxiliary tools Disassembly		Machine shaft
	d	l ₁	d ₂	l ₉	c ₇	c ₈	c ₉	max l ₈
	H7							
GSS04...	25	100	M10	40	5	10	3	85
GSS05...	30				6			
	35	124	M12	50	7	12		107
GSS06...	40	140	M16	60	8	16	4	118
	45				9			
GSS07...	50	175	M20	80	10	20	5	148
	55				11			